**TECHNICAL BULLETIN
INSTALLATION INSTRUCTIONS
FOR RETRANSMISSION VEHICLE WITH AMTECH TOP**

FOR SYSTEMS

**SINGLE CHANNEL GROUND AND AIRBORNE
RADIO SYSTEM (SINGARS)
AN/VRC-88F, AN/VRC-90F**

**FORCE XXI BATTLE COMMAND, BRIGADE-AND-BELOW (FBCB2)
AN/UYK-128 (V)4**

**NEAR TERM DIGITAL RADIO (NTDR)
RT-1812**

**ENHANCED POSITION LOCATION REPORTING SYSTEM (EPLRS)
AN/VSQ-2 (V)**

**QUICK ERECT ANTENNA MOUNT (QEAM)
AB-1386/U**

**PRECISION LIGHTWEIGHT GPS RECEIVER (PLGR)
AN/PSN-11**

SUPPLEMENTAL BATTERIES

FOR VEHICLES

**TRUCK, UTILITY, 2/4-DOOR: CARGO/TROOP CARRIER, 1-1/4 TON, 4X4,
M998 (2320-01-107-7155) (EIC: BBD); M998A1 (2320-01-371-9577) (EIC: BBN);**

**TRUCK, UTILITY, 2/4-DOOR: HEAVY VARIANT, 1-1/4 TON, 4X4,
M1097 (2320-01-346-9317) (EIC: BBM); M1097A1 (2320-01-371-9583) (EIC: BBU);
M1097A2 (2320-01-380-8604) (EIC: BB6).**

Approved for public release; distribution is unlimited.

HEADQUARTERS, DEPARTMENT OF THE ARMY

SEPTEMBER 2005

CHANGE
NO. 1

HEADQUARTERS
DEPARTMENT OF THE ARMY,
Washington, D.C., 1 OCTOBER 2006

**TECHNICAL BULLETIN
INSTALLATION INSTRUCTIONS
FOR RETRANSMISSION VEHICLE WITH AMTECH TOP**

FOR SYSTEMS

**SINGLE CHANNEL GROUND AND AIRBORNE RADIO SYSTEM (SINGARS)
AN/VRC-88F, AN/VRC-90F**

**FORCE XXI BATTLE COMMAND, BRIGADE-AND-BELOW (FBCB2)
AN/UYK-128 (V)4**

**NEAR TERM DIGITAL RADIO (NTDR)
RT-1812**

**ENHANCED POSITION LOCATION REPORTING SYSTEM (EPLRS)
AN/VSQ-2 (V)**

**QUICK ERECT ANTENNA MOUNT (QEAM)
AB-1386/U**

**PRECISION LIGHTWEIGHT GPS RECEIVER (PLGR)
AN/PSN-11**

SUPPLEMENTAL BATTERIES

FOR VEHICLES

**TRUCK, UTILITY, 2/4-DOOR: CARGO/TROOP CARRIER, 1-1/4 TON, 4X4,
M998 (2320-01-107-7155) (EIC: BBD); M998A1 (2320-01-371-9577) (EIC: BBN);**

**TRUCK, UTILITY, 2/4-DOOR: HEAVY VARIANT, 1-1/4 TON, 4X4,
M1097 (2320-01-346-9317) (EIC: BBM); M1097A1 (2320-01-371-9583) (EIC: BBU);
M1097A2 (2320-01-380-8604) (EIC: BB6).**

TB 9-2320-280-35-10, 17 September 2005, is changed as follows:

1. Remove old pages and insert new pages as indicated below.
2. New or changed material is indicated by a vertical bar in the margin of the page.

Remove pages

A/(B blank)
i through iii/(iv blank)
4-3 through 4-9/(4-10 blank)
5-15 through 5-18
5-41 and 5-42
5-45 and 5-46
5-49 and 5-50
5-55 through 5-60
5-87 and 5-88
5-101/(5-102 blank)
DA Form 2028

Insert page

A/(B blank)
i through iii/(iv blank)
4-3 through 4-9/(4-10 blank)
5-15 through 5-18
5-41 and 5-42
5-45 and 5-46
5-49 and 5-50
5-55 through 5-60
5-87 and 5-88
5-101 through 5-111/(5-112 blank)
DA Form 2028

3. File this change sheet in front of the publication for reference purposes.

Approved for public release; distribution is unlimited.

By Order of the Secretary of the Army:

PETER J. SCHOOMAKER
General, United States Army
Chief of Staff

Official:

A handwritten signature in black ink that reads "Joyce E. Morrow". The signature is written in a cursive, flowing style.

JOYCE E. MORROW
Administrative Assistant to the
Secretary of the Army
0617809

Distribution:

To be distributed in accordance with the Initial Distribution Number (IDN) 344825 requirements for TB 9-2320-280-35-10.

LIST OF EFFECTIVE PAGES

NOTE

A vertical line in the outer margins of the page indicates the portion of text affected by the change.

Dates of issue for original and change pages are:

Original 0 17 September 2005

Change 1 1 October 2006

TOTAL NUMBER OF PAGES IN THIS PUBLICATION IS 145 PAGES.

Page No.	*Change No.
A/(B blank)	1
i-iii/(iv blank)	1
1-1-4-2	0
4-3-4-9/(4-10 blank)	1
5-1-5-15	0
5-16	1
5-16.1-5-16.4 Added	1
5-17	1
5-18-5-40	0
5-41	1
5-42-5-44	0
5-45	1
5-46-5-49	0
5-50	1
5-51-5-54	0
5-55-5-60	1
5-61-5-87	0
5-88	1
5-89-5-100	0
5-101	1
5-102-5-111/(5-112 blank) Added	1

*Zero in this column indicates original page.

TECHNICAL BULLETIN
NO. 9-2320-280-35-10

HEADQUARTERS,
DEPARTMENT OF THE ARMY
WASHINGTON, D.C., 17 SEPTEMBER 2005

TECHNICAL BULLETIN INSTALLATION INSTRUCTIONS FOR RETRANSMISSION VEHICLE WITH AMTECH TOP

FOR SYSTEMS

SINGLE CHANNEL GROUND AND AIRBORNE RADIO SYSTEM (SINGARS)
AN/VRC-88F, AN/VRC-90F

FORCE XXI BATTLE COMMAND, BRIGADE-AND-BELOW (FBCB2)
AN/UYK-128 (V)4

NEAR TERM DIGITAL RADIO (NTDR)
RT-1812

ENHANCED POSITION LOCATION REPORTING SYSTEM (EPLRS)
AN/VSQ-2 (V)

QUICK ERECT ANTENNA MOUNT (QEAM)
AB-1386/U

PRECISION LIGHTWEIGHT GPS RECEIVER (PLGR)
AN/PSN-11

SUPPLEMENTAL BATTERIES

FOR VEHICLES

TRUCK, UTILITY, 2/4-DOOR: CARGO/TROOP CARRIER, 1-1/4 TON, 4X4,
M998 (2320-01-107-7155) (EIC: BBD); M998A1 (2320-01-371-9577) (EIC: BBN);

TRUCK, UTILITY, 2/4-DOOR: HEAVY VARIANT, 1-1/4 TON, 4X4,
M1097 (2320-01-346-9317) (EIC: BBM); M1097A1 (2320-01-371-9583) (EIC: BBU);
M1097A2 (2320-01-380-8604) (EIC: BB6).

REPORTING ERRORS AND RECOMMENDING IMPROVEMENTS

You can help improve this publication. If you find any mistakes or if you know of a way to improve the procedures, please let us know. Submit your DA Form 2028 (Recommended Changes to Equipment Technical Publications), through the Internet, on the Army Electronic Product Support (AEPS) website. The Internet address is <https://aeps.ria.army.mil>. The DA Form 2028 is located under the Public Applications section in the AEPS Public Home Page. Fill out the form and click on SUBMIT. Using this form on the AEPS will enable us to respond quicker to your comments and better manage the DA Form 2028 program. You may also mail, fax or E-mail your letter or DA Form 2028 direct to: AMSTA-LC-LPIT/TECH PUBS, TACOM-RI, 1 Rock Island Arsenal, Rock Island, IL 61299-7630. The email address is TACOM-TECH-PUBS@ria.army.mil. The fax number is DSN 793-0726 or Commercial (309) 782-0726.

Approved for public release; distribution is unlimited.

TABLE OF CONTENTS

		Page
	LIST OF TABLES	iii
CHAPTER 1.	INTRODUCTION	1-1
Section I.	Scope	1-1
Section II.	Notes	1-1
Section III.	General Information	1-1
Section IV.	Maintenance Forms, Records, and Reports	1-1
Section V.	Consolidated Index of Army Publications	1-1
CHAPTER 2.	PURPOSE OF INSTALLATION	2-1
CHAPTER 3.	COMPLETION TIME FOR INSTALLATION	3-1
CHAPTER 4.	PREPARATION FOR INSTALLATION	4-1
Section I.	Preparation of Vehicle	4-1
Section II.	Items to be Removed	4-1
Section III.	List of Items to be Retained	4-1
Section IV.	Preparation of C4ISR Equipment	4-1
Section V.	Precautions During Handling	4-1
Section VI.	Unpack and Inspect Equipment	4-1
Section VII.	Inventory C4ISR Equipment	4-1
Section VIII.	Examine Each Item for Damage	4-2
Section IX.	C4ISR Equipment, Distribution, and Consumables	4-2
Section X.	Distribution and Issue Instructions	4-2
Section XI.	Parts List	4-2
CHAPTER 5.	INSTALLATION PROCEDURES	5-1
Section I.	Scope	5-1
Section II.	Installation of Terminal Boards	5-1
Section III.	Panel Modifications	5-1
Section IV.	Terminal Board, Cover, and Link Modification	5-3
Section V.	B-Beam Preparation	5-4
Section VI.	Assembly of Cab Enclosure Panel	5-5
Section VII.	Final Assembly, Terminal Board Wiring, and Terminal Link	5-6
Section VIII.	Integrated Rack Installation	5-11
Section IX.	Installation of SINCGARS Mounting Tray and Amp Guard	5-13
Section X.	Front Power Amplifier Installation	5-14
Section XI.	FBCB2 Components Installation	5-16
Section XI.A.	Serial Interface Adapter Device (SIAD) Cables Installation	5-16.2
Section XI.B.	Serial Interface Adapter Device (SIAD) Installation	5-16.3
Section XI.C.	FBCB2 Cables Installation	5-16.4

TABLE OF CONTENTS (Contd)

		Page
Section XII.	Loudspeaker and Multi-Net Rack Installation	5-18
Section XIII.	Charge Control Box Installation	5-23
Section XIV.	Rear SINGARS Mount Installation	5-24
Section XV.	Rear Power Amplifier Installation	5-26
Section XVI.	NTDR Mounting	5-31
Section XVII.	EPLRS Mount Installation	5-33
Section XVIII.	User Readout (URO) Bracket Installation	5-34
Section XIX.	Charger Installation	5-35
Section XX.	EPLRS Antenna and NTDR Antenna Installation	5-37
Section XXI.	Left-Side SINGARS Antenna Mount Installation	5-38
Section XXII.	Right-Side SINGARS Antenna Mount Installation	5-42
Section XXIII.	QEAM Mounting: Antennas and Brackets	5-46
Section XXIV.	SINGARS Cables Installation	5-50
Section XXV.	PLGR Bracket Installation	5-54
Section XXVI.	PLGR Antenna and Cable Installation (Without Bolt-On Armor)	5-55
Section XXVII.	Loudspeaker Cables Installation	5-61
Section XXVIII.	EPLRS Antenna Cable and NTDR Antenna Cable Installation	5-64
Section XXIX.	EPLRS Power and INC-EPUU Cable Installation	5-66
Section XXX.	NTDR Power Cable and UHF Cable Installation	5-69
Section XXXI.	C4ISR Power Cables Installation	5-70
Section XXXII.	Windshield Armor Modification	5-102
Section XXXIII.	Armor and Antenna Installation (With Bolt-On Armor)	5-105
Section XXXIV.	Antenna Cable Installation (With Bolt-On Armor)	5-109

LIST OF TABLES

Table	Title	Page
4-1.	Kits Parts List for Installation of C4ISR Equipment	4-3
4-2.	Non-Kit Parts List for Installation of C4ISR Equipment	4-5

CHAPTER 1

INTRODUCTION

Section I. SCOPE

- 1-1.** This technical bulletin provides installation instructions for Command, Control, Communications, Computers, Intelligence, Surveillance, and Reconnaissance (C4ISR) equipment. The C4ISR equipment shall be installed in the following vehicles:
- a. Truck, Utility, 2/4-Door: Cargo/Troop Carrier, 1-1/4 Ton, 4x4, M998, M998A1
 - b. Truck, Utility, 2/4-Door: Heavy Variant, 1-1/4 Ton, 4x4, M1097, M1097A1, M1097A2
- 1-2.** The information contained in this technical bulletin is the official authorization to perform the installation of the C4ISR equipment at the direct support maintenance level through contract maintenance teams.

Section II. NOTES

- 2-1.** This technical bulletin is not an authorization for requisition or turn-in of vehicles.
- 2-2.** This technical bulletin does not establish quantity or types of vehicles assigned to using units.

Section III. GENERAL INFORMATION

- 3-1.** Included in the C4ISR equipment are:
- a. Single Channel Ground and Airborne Radio System (SINCGARS) AN/VRC-88F, AN/VRC-90F
 - b. Force XXI Battle Command, Brigade-and-Below (FBCB2) AN/UYK-128 (V)4
 - c. Near Term Digital Radio (NTDR) RT-1812
 - d. Enhanced Position Location Reporting System (EPLRS) AN/VSQ-2 (V)
 - e. Quick Erect Antenna Mount (QEAM) AB-1386/U
 - f. Precision Lightweight GPS Receiver (PLGR) AN/PSN-11
 - g. Supplemental batteries
 - h. Additional terminal boards
- 3-2.** The C4ISR equipment becomes operable when all the components are installed in the vehicle and correct power is supplied.

Section IV. MAINTENANCE FORMS, RECORDS, AND REPORTS

Use the following to report any discrepancies:

- a. Reports of Maintenance and Unsatisfactory Equipment. See chapter 4, sections VI through VIII for information.
- b. Report of Packaging and Handling Deficiencies. See chapter 4, sections VI through VIII for information.
- c. Discrepancy in Transportation Deficiency Report (TDR) (SF361). See chapter 4, sections VI through VIII for information.

Section V. CONSOLIDATED INDEX OF ARMY PUBLICATIONS

Refer to the latest issue of DA PAM 25-30 to determine whether there are new changes or additional publications pertaining to the C4ISR equipment.

CHAPTER 2

PURPOSE OF INSTALLATION

The purpose of installing the C4ISR equipment is to provide the primary means of integrating command and control systems.

CHAPTER 3

COMPLETION TIME FOR INSTALLATION

A total of 20 man hours are required for two personnel to install the C4ISR equipment. Typical vehicle downtime is 12 hours.

CHAPTER 4

PREPARATION FOR INSTALLATION

Section I. PREPARATION OF VEHICLE

Ensure that the site includes adequate lighting and a power source when drilling is required. Inspect the vehicle for damage that could affect installation. Have any such damage repaired before installing the C4ISR equipment.

Section II. ITEMS TO BE REMOVED

- 2-1. Remove batteries. (Refer to TM 9-2320-280-20.)
- 2-2. Remove right-hand rear cab enclosure panel. (Refer to TM 9-2320-280-20.)
- 2-3. Remove insulation floorboard. (Refer to TM 9-2320-280-20.)
- 2-4. Remove standard radio rack. (Refer to TM 9-2320-280-20.)

Section III. LIST OF ITEMS TO BE RETAINED

- 3-1. Batteries.
- 3-2. Right-hand rear cab enclosure panel (if applicable).

Section IV. PREPARATION OF C4ISR EQUIPMENT

Unpack, inspect, and check inventory.

Section V. PRECAUTIONS DURING HANDLING

Observe the following precautions to prevent equipment damage.

- a. Keep dust covers in place on connectors.
- b. Do not disassemble or modify parts in the C4ISR equipment unless authorized to do so.
- c. Keep mounting hardware covered and protected until needed.

Section VI. UNPACK AND INSPECT EQUIPMENT

- 6-1. Unpack and inspect packaging for evidence of damage.
- 6-2. Report any shipping damage on SF 364 Report of Discrepancy (ROD) as prescribed in AR 735-11-2/DLAR 4140.55/NAVMATINST 4355.73A/AFR 400-64/MCO 4430.F.

Section VII. INVENTORY C4ISR EQUIPMENT

If any item is missing, fill out and forward Transportation Discrepancy Report (TDR) (SF 361) as described in AR 55-38/NAVSUPINST 4610.33C/AFR 75-18/MCO P4610.19D/DLAR 450015.

Section VIII. EXAMINE EACH ITEM FOR DAMAGE

If any item is damaged, fill out and forward SF 364 Report of Discrepancy (ROD) as prescribed in AR 735-11-2/DLAR 4140.55/NAVMATINST 4355.73A/AFR 400-64/MCO 4430.F. All damages should be reported as prescribed by DA PAM 738-750, as contained in the Maintenance Management Update.

Section IX. C4ISR EQUIPMENT, DISTRIBUTION, AND CONSUMABLES

- 9-1. Items supplied in C4ISR equipment and/or required for installation.
- 9-2. Use table 4-1 to identify and inventory C4ISR equipment parts supplied to perform installation. Refer to table 4-2 to identify additional materials required to install C4ISR equipment.

Section X. DISTRIBUTION AND ISSUE INSTRUCTIONS

- 10-1. U.S. Forces: Do not requisition C4ISR equipment. They will be shipped automatically.
- 10-2. U.S. Army Depots: Requisition C4ISR equipment through supply channels.
- 10-3. Multiservice: Instructions shall be included for multiservice modifications.
- 10-4. MAP/MAS countries: Instructions shall be provided for MAP/MAS countries.

Section XI. PARTS LIST

KITS REQUIRED FOR THIS INSTALLATION:

NOTE

- Not all material in kits is required for this installation. Material not used during installation will be returned to stock for disposition in accordance with AR 725-50.
- If maintenance is to be performed on a vehicle with an existing kit, do not order entire kit for necessary reinstallation.

SINGARS:

(A): MK-2327 (dual)

PLGR:

(B): 57K4400

EPLRS:

(C): MK-2467A/VSQ-1

(D): MK-2753/VSQ

FBCB2:

(E): No kits available

NTDR:

(F): No kits available

QEAM:

(G): No kits available

SUPPLEMENTAL BATTERIES:

(H): No kits available

MATERIAL REQUIRED FROM KITS:*Table 4-1. Kit Parts List for Installation of CAISR Equipment.*

ITEM NO.	NOMENCLATURE	PART NUMBER	NSN	KIT	QTY.
1.	Antenna	A3005031	5820-01-183-9462	(C)	1
2.	Antenna Element, Lower	A3018230-1	5985-01-201-1498	(A)	2
3.	Antenna Element, Upper	A3017901-2	5985-01-306-4622	(A)	2
4.	Bracket, Antenna	A3014546-1	5340-01-391-2742	(A)	1
5.	Bracket, Double-Angle	A3046237	5340-01-262-9566	(D)	2
6.	Bracket, PLGR Mount	12480578	N/A	(B)	1
7.	Bracket, Radio Rack Mounting	A3046235	5340-01-262-9563	(D)	2
8.	Bracket, User Readout (URO)	A3006206	5340-01-386-7841	(C)	1
9.	Cable, Antenna	A32551281W23	5995-01-468-9827	(B)	1
10.	Cable Assembly, Antenna	A3014031-17	5995-01-225-1660	(A)	1
11.	Cable Assembly, Antenna, EPLRS	SM-C-911480	5995-01-167-1269	(C)	1
12.	Cable Assembly, Power, EPLRS	A3004939	5995-01-198-0538	(C),(D)	2
13.	Cable Assembly, Radio Frequency	A3014031-8	5995-01-219-7035	(A)	1
14.	Clamp, Loop	MS21333-67	5340-00-079-7837	(B)	1
15.	Clamp, Loop	MS21333-71	5340-00-057-2904	(A)	2
16.	Clamp, Loop	MS21333-75	5340-00-050-2740	(A)	1
17.	Clamp, Loop	MS21333-96	5340-00-088-1255	(B)	2
18.	Grommet, Nonmetallic	MS21266-4N	5325-00-923-9512	(A)	2
19.	Grommet	MS35489-31	5325-00-174-9336	(B)	1
20.	Grommet, Nonmetallic	MS35489-143	5325-00-292-7558	(B)	2
21.	Insert	12446871-2	5310-01-411-3422	(B)	3
22.	Loudspeaker	A3014065-1	5965-01-222-1420	(A)	4
23.	Mounting Base, Electrical Equipment	A3013367-1	5975-01-188-8873	(A),(D)	2
24.	Nut	271169	5310-00-124-9265	(B)	2
25.	Nut	9419143	5310-01-148-0240	(B)	2
26.	Nut	MS35650-302	5310-00-934-9751	(A),(C),(D)	7
27.	Nut	MS51967-2	5310-00-761-6882	(A),(C)	6
28.	Nut	MS51968-5	5310-00-880-7746	(A),(D)	10
29.	Nut, Lock	271175	5310-01-333-5245	(B)	1
30.	Screw, Cap	B1821BH025C100N	5305-00-225-3843	(B)	3
31.	Screw, Cap	B1821BH025C125N	5305-00-068-0509	(B)	2
32.	Screw, Cap	B1821BH025C175N	5305-00-071-2510	(B)	1
33.	Screw, Cap	MS35207-261	5305-00-990-6444	(B)	1
34.	Screw, Cap	MS35307-365	5305-00-847-1159	(A),(D)	8
35.	Screw, Cap	MS90725-8	5305-00-225-3839	(A),(D)	2
36.	Screw, Cap	MS90726-36	5305-00-225-9091	(A)	6
37.	Screw, Externally Relieved	p/o A3014065-1	N/A	(A)	8
38.	Screw, Machine	MS35206-217	5305-00-889-2999	(C)	3

MATERIAL REQUIRED FROM KITS (Contd):

Table 4-1. Parts List for Installation of C4ISR Equipment (Contd).

ITEM NO.	NOMENCLATURE	PART NUMBER	NSN	KIT	QTY.
39.	Screw, Machine	MS35206-263	5305-00-984-6210	(B)	4
40.	Screw, Self-tapping	9421073	5305-01-162-8512	(B)	6
41.	Screw, Self-tapping	9416639	5305-01-197-2320	(B)	1
42.	Strap, Tiedown	MS3367-1-0	5975-00-984-6582	(B)	3
43.	Terminal Lug	7728777	5940-00-983-4067	(B)	1
44.	Terminal Lug	7728780	5940-01-035-4212	(B)	2
45.	Washer	2436161	5310-01-102-3270	(B)	8
46.	Washer	MS27183-10	5310-00-809-4058	(A)	16
47.	Washer, Lock	MS35338-43	5310-00-045-3296	(A),(B),(C)	7
48.	Washer, Lock	MS35338-44	5310-00-582-5965	(A)	24
49.	Washer, Lock	MS35338-46	5310-00-637-9541	(A),(C),(D)	7
50.	Washer, Lock	MS35338-48	5310-00-584-5272	(A)	2
51.	Washer, Lock	MS45904-68	5310-00-889-2528	(A)	9
52.	Washer, Lock	MS45904-72	5310-00-889-2527	(A),(C),(D)	89
53.	Washer, Lock	MS45904-76	5310-00-061-1258	(A),(D)	6
54.	Wellnut	12339397-3	5310-01-231-7455	(B)	1
55.	Wellnut	12339397-6	5310-01-388-6205	(B)	1

MATERIAL REQUIRED BUT NOT INCLUDED IN KITS (Contd):*Table 4-2. Non-Kit Parts List for Installation of C4ISR Equipment.*

ITEM NO.	NOMENCLATURE	PART NUMBER	NSN	QTY.
1.	Angle, Steel	p/o PKMM 000-016	N/A	1
2.	Antenna AS-3900/VRC	A3017899-2	5985-01-308-8988	2
3.	Antenna Support	A3103782	5985-01-312-3028	2
4.	Antenna, NTDR	8173964-1	N/A	1
5.	Antenna, PLGR	AT575-030	5985-01-375-4660	1
6.	Assembly, Display Lock	872843-01	N/A	1
7.	Backing Plate	p/o PKMM 000-006	N/A	2
8.	Backing Plate	A3046222	5975-01-264-1720	2
9.	Bar, Aluminum Flat	p/o PKMM 000-017	N/A	1
10.	Battery, Deep Cycle	PKMM 000-010	N/A	2
11.	Bolt	MS35751-18	5306-00-108-9988	4
12.	Bracket, PLGR	986-0645-001	5975-01-375-1302	1
13.	Cable (battery to battery)	RCSK 19639	N/A	1
14.	Cable (shunt to rear battery)	RCSK 19643	N/A	1
15.	Cable (solenoid to rear battery)	RCSK 19644	N/A	1
16.	Cable Assembly, Antenna, PLGR	426-0141-050	6150-01-375-8662	1
17.	Cable Assembly, Ground	12480567-1	N/A	1
18.	Cable Assembly, Power	12480567-2	N/A	1
19.	Cable Assembly, Power	8174912-2	N/A	1
20.	Cable Assembly, Power	A3014039-2	5995-01-219-1843	2
21.	Cable Assembly, Power	A3014039-7	5995-01-336-6933	1
22.	Cable Assembly, Power	A3279383-2	5995-01-453-6608	1
23.	Cable Assembly, Power	PKMM 0004	N/A	2
24.	Cable Assembly, Power, Electrical	A3154857-1	5995-01-438-7822	1
25.	Cable Assembly, Power, PLGR	9728558-10	6150-01-375-8661	1
26.	Cable Assembly, Radio Frequency	A3014032-3	5995-01-219-7025	1
27.	Cable Assembly, Special Purpose	A3210672-1	5995-01-444-7933	1
28.	Cable (shunt)	RCSK-19638	N/A	1
29.	Cable (solenoid)	RCSK-19637	N/A	1
30.	Cable, Control Box (GREEN)	N/A	N/A	1
31.	Cable, Control Box (ORANGE)	N/A	N/A	1
32.	Cable, Control Box (RED)	N/A	N/A	1
33.	Cable, Speaker	A3014038-3	5995-01-219-4704	4
33.1.	Cable, W1	866003-3	5995-01-478-4908	1
33.2.	Cable, W2	881327-1	5995-01-478-4876	1
33.3.	Cable, W3N	881336-1	5995-01-478-4913	1
33.4.	Cable, W3P	881335-1	5995-01-478-4891	1
34.	Charge Control Box	PKMM-000-002	N/A	1
35.	Clamp, Loop	A3209994	5340-01-424-1516	4
36.	Clamp, Loop	MS21333-65	5340-00-905-0790	10

MATERIAL REQUIRED BUT NOT INCLUDED IN KITS (Contd):*Table 4-2. Non-Kit Parts List for Installation of CAISR Equipment (Contd).*

ITEM NO.	NOMENCLATURE	PART NUMBER	NSN	QTY.
37.	Clamp, Loop	MS21333-67	5340-00-079-7837	3
38.	Clamp, Loop	MS21333-69	5340-00-764-7051	10
39.	Clamp, Loop	MS21333-71	5340-00-057-2904	2
40.	Clamp, Loop	MS21333-77	5340-00-922-6300	4
41.	CPU (Central Processing Unit)	881292-1	7021-01-474-3793	1
42.	Decal	12339060	7690-01-265-1135	1
43.	Decal	861868-2	N/A	1
43.1.	Device, Serial Interface Adapter	881331-1	4920-01-478-3722	1
44.	Display	881293-1	7025-01-475-0229	1
45.	Folding Step	p/o PKMM 000-006	N/A	2
46.	Frame	A3210675-1	N/A	1
47.	Gasket	A3013655-1	5330-01-205-2864	4
48.	Grommet, Nonmetallic	2400	5325-01-289-7859	1
49.	Grommet, Nonmetallic	12338098	5325-01-308-5424	2
50.	Grommet, Nonmetallic	MS21266-4N	5325-00-923-9512	A/R
51.	Grommet, Nonmetallic	MS21266-6N	5325-00-783-4753	A/R
52.	Grommet, Nonmetallic	12341628	N/A	A/R
53.	Guard, Amp	872842-1	5935-01-487-2172	1
54.	Insert	12446871-2	5310-01-411-3422	5
55.	Isolation Kit, CPU	872826-2	5340-01-481-5741	1
56.	Isolation Kit, Display	872870-1	5340-01-481-5757	1
57.	Lanyard	8925T5-7X19	4010-01-497-2675	1
58.	Mount, Ramball	RAM-D-111U	5975-01-485-3615	1
59.	Mount, Resilient	MT-6146/VSQ	5340-01-167-8297	1
60.	Mounting Base, Electrical Equipment	A3014053-1	5975-01-235-1962	2
61.	Mounting Tray	8174934G1	N/A	1
62.	Nut	p/o PKMM 000-016	N/A	2
63.	Nut	9418892	5310-01-157-9819	9
64.	Nut	13218E0320-293	5310-00-913-8881	4
65.	Nut	MS35360-302	N/A	3
66.	Nut	MS35649-2252	5310-00-997-1888	3
67.	Nut	MS35649-2382	5310-00-056-3395	2
68.	Nut	MS35649-63	5310-00-804-3859	5
69.	Nut	MS51967-9	5310-00-761-0654	1
70.	Nut	271169	5310-00-124-9265	3
71.	Nut	9419143	5310-01-148-0240	15
72.	Nut	MS51967-5	5310-00-880-7744	18
73.	Nut	MS35690-610	5310-00-655-6457	24
74.	Nut	MS51967-6	5310-00-931-8167	4
75.	Nut, Lock	271175	5310-01-333-5245	5

MATERIAL REQUIRED BUT NOT INCLUDED IN KITS (Contd):*Table 4-2. Non-Kit Parts List for Installation of C4ISR Equipment (Contd).*

ITEM NO.	NOMENCLATURE	PART NUMBER	NSN	QTY.
76.	Nut, Nylok	p/o PKMM 000-016	N/A	2
77.	Nut, Self-Locking	MS17829-5C	5310-00-245-3424	4
78.	Nut, Self-Locking	MS17829-4C	5310-00-483-8792	6
79.	Nut, Self-Locking	MS21044-NO4	5310-00-088-0551	3
80.	Nut, Self-Locking	MS21044-NO8	5310-00-811-3494	2
81.	Nut Strip	A3014064-1	N/A	2
82.	Panel, Enclosure	12447141	2510-01-413-5993	1
83.	Plate	A3103784	N/A	2
84.	Plate, Angled	A3103740	5340-01-302-0068	2
85.	Plate, Mounting	A3014550-1	N/A	4
86.	Rack, Integrated	A3276903	N/A	1
87.	Rack, QEAM	PKMM 000-006	N/A	1
88.	Rivet, Blind	12339355-1	5320-01-271-6357	2
89.	Rivet, Blind	M24243/1A403	5320-00-083-5009	4
90.	RTV	12346193	6850-01-159-4844	A/R
91.	Screw, All Thread	N/A	N/A	2
92.	Screw, Cap	8599267-531	5305-00-847-1159	4
93.	Screw, Cap	B1821BH038C225N	5305-01-434-2947	2
94.	Screw, Cap	B1821BH025C075N	5305-00-068-0508	4
95.	Screw, Cap	B1821BH025C150N	5305-00-071-2509	6
96.	Screw, Cap	B1821BH031C125N	2306-00-226-4829	6
97.	Screw, Cap	B1821BH031F075N	5306-00-050-1238	4
98.	Screw, Cap	B1821BH031F100N	5305-00-051-4076	6
99.	Screw, Cap	B1821BH031F125N	5305-00-051-4078	13
100.	Screw, Cap	B1821BH038F100N	5305-00-269-3236	6
101.	Screw, Cap	B1821BH050C400N	5305-00-071-2079	3
102.	Screw, Cap	B1821BH050C450N	5305-00-071-2081	2
103.	Screw, Cap	B1821BH025C100N	5305-00-225-3843	7
104.	Screw, Cap	B1821BH025C125N	5305-00-068-0509	15
105.	Screw, Cap	MS35307-365	5305-00-847-1159	4
106.	Screw, Cap	MS90726-36	5305-00-225-9091	12
107.	Screw, Cap	MS90725-64	5305-01-325-8387	32
108.	Screw, Cap	MS90725-62	5305-00-269-3213	8
109.	Screw, Cap	B1821BH031C300N	5306-00-226-4837	4
110.	Screw, Machine	160035	5305-00-016-0035	1
111.	Screw, Machine	MS35206-230	5305-00-889-3000	5
112.	Screw, Machine	MS35206-247	5305-00-984-6195	2
113.	Screw, Machine	MS35207-265	5305-00-993-1848	7
114.	Screw, Machine	MS35207-263	5305-00-989-7434	2
115.	Screw, Machine	MS35224-65	5305-00-543-5743	1

MATERIAL REQUIRED BUT NOT INCLUDED IN KITS (Contd):

Table 4-2. Non-Kit Parts List for Installation of C4ISR Equipment (Contd).

ITEM NO.	NOMENCLATURE	PART NUMBER	NSN	QTY.
116.	Screw, Machine	MS90725-30	5306-00-225-8495	8
117.	Screw, Machine	MS35190-291	5305-00-958-5247	2
118.	Screw, Machine, Self-Tapping	9421073	5305-01-162-8512	21
119.	Screw, Self-Tapping	9426241	5305-01-206-7219	1
120.	Screw, Self-Tapping	12342499-2	5305-01-264-5809	7
121.	Sheet, Rubber	N/A	N/A	1
122.	Shelf, Electrical Equipment	A3046236	5975-01-262-9575	2
123.	Shunt	PKMM 000-013	N/A	1
124.	Solenoid	586-905	5945-01-411-7621	1
125.	Spacer	10705AL315C	5365-01-487-3145	4
126.	Spacer, QEAM	p/o PKMM 000-006	N/A	4
127.	Strap, Tiedown	MS3367-1-0	5975-00-984-6582	A/R
128.	Terminal Block	MS27212-1-23	N/A	1
129.	Terminal Board	105A	5940-01-208-4713	1
130.	Terminal Board	MS27212-3-8	5940-00-950-7782	1
131.	Terminal Board Cover	12480569-1	N/A	1
132.	Terminal Board Cover	12480569-2	N/A	1
133.	Terminal Board Cover	MS18029-3S-2	5940-01-280-9304	1
134.	Terminal Cover	MS18029-1L-16	N/A	1
135.	Terminal Link	MS25226-6N-2	6150-01-167-9267	1
136.	Terminal Lug	7728777	5940-00-983-4067	1
137.	Terminal Lug	MS20659-129	5940-00-114-1314	2
138.	Terminal Lug	MS20659-141	5940-00-113-9825	4
139.	Tubing, Convolutd	N/A	N/A	A/R
140.	Tubing, Shrink	MS23053/4-302-0	5970-01-161-6796	A/R
141.	Washer, Fender	p/o PKMM 000-016	N/A	2
142.	Washer	2436163	5310-01-412-4013	18
143.	Washer	9414920	5310-01-476-8589	2
144.	Washer	9417373	5310-01-361-1163	1
145.	Washer	11500256	5310-00-080-6004	1
146.	Washer	MS27183-14	5310-00-080-6004	4
147.	Washer	MS27183-4	5310-00-950-1310	3
148.	Washer	MS27183-8	5310-00-809-8546	6
149.	Washer	MS27183-41	5310-00-765-3197	2
150.	Washer	MS51412-23	5310-01-333-0060	2
151.	Washer	MS51412-25	5310-00-044-6477	2
152.	Washer	2436161	5310-01-102-3270	41
153.	Washer	2436165	5310-01-121-1703	5
154.	Washer	MS27183-12	5310-00-081-4219	10
155.	Washer	120393	5310-00-012-0393	8

MATERIAL REQUIRED BUT NOT INCLUDED IN KITS (Contd):*Table 4-2. Non-Kit Parts List for Installation of C4ISR Equipment (Contd).*

ITEM NO.	NOMENCLATURE	PART NUMBER	NSN	QTY.
156.	Washer	MS15795-814	5310-00-773-7618	52
157.	Washer	MS45904-84	5310-00-935-8984	5
158.	Washer	MS35338-141	5310-01-422-3906	26
159.	Washer, Lock	120380	5310-00-543-2705	4
160.	Washer, Lock	MS35338-41	5310-00-045-4007	5
161.	Washer, Lock	MS35338-48	5310-00-584-5272	1
162.	Washer, Lock	MS45904-72	5310-00-889-2527	20
163.	Wingnut	MS35425-75	5310-01-078-5996	1
164.	Wingnut	MS51553-420	5310-01-384-2546	4
165.	Wire Assembly, Fuse (12V)	12480568-2	N/A	1
166.	Wire Assembly, Fuse (24V)	12480568-1	N/A	3
167.	Wire, Braided	AA59569F30T0375	6145-00-191-8402	A/R
168.	Wire, Lock	MS20995C32	9505-00-293-4208	A/R

CHAPTER 5 INSTALLATION PROCEDURES

Section I. SCOPE

This chapter provides instructions for installation of C4ISR items in the vehicle. When installing C4ISR equipment, be sure to read and follow instructions and illustrations carefully.

Section II. INSTALLATION OF TERMINAL BOARDS

Use the following procedure to install additional terminal boards to provide adequate power connections.

Section III. PANEL MODIFICATIONS

NOTE

- For vehicles without cab enclosure panel, begin with step 3-1 and use cab enclosure panel NSN 2510-01-413-5993.
 - For vehicles with cab enclosure panel, begin with step 3-3.
 - All dimensions are in inches.
- 3-1.** Place cab enclosure panel (3) in position. Locate, mark, and drill five 0.159-in. diameter holes marked A and B in B-beam (1) and battery box (2).
- 3-2.** Enlarge two lower mounting holes marked A to 0.390-in. diameter, and install two inserts (4) in battery box (2).

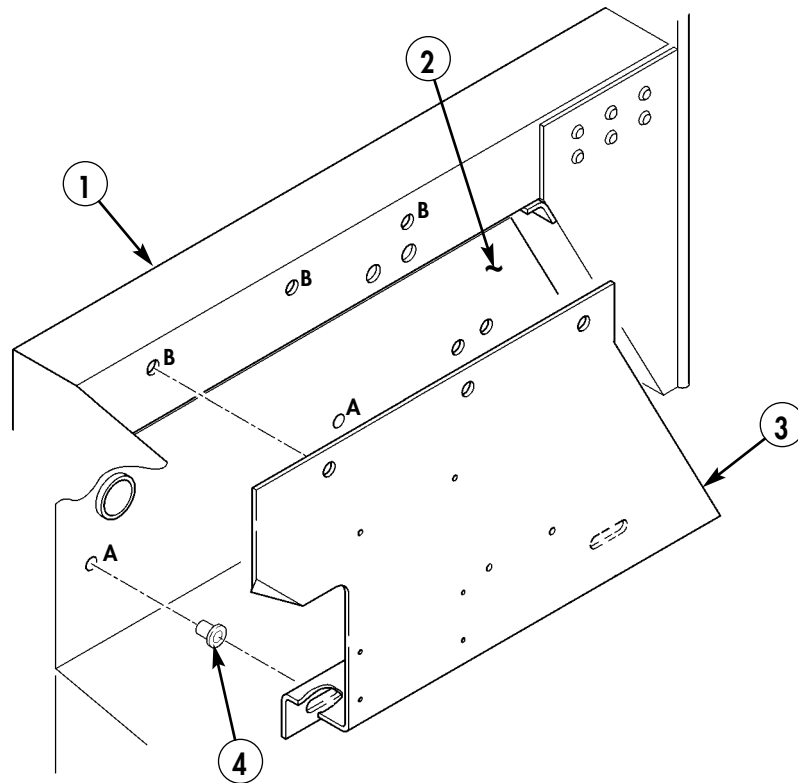

- 3. CAB ENCLOSURE PANEL – 12447141 – QTY. 1**
4. INSERT – 12446871-2 – QTY. 2

Figure 5-1.

NOTE

Do not install cab enclosure panel.

- 3-3. Locate, mark, and drill three 0.156-in. diameter holes marked A in cab enclosure panel (1).
- 3-4. Locate, mark, and drill two 0.156-in. diameter holes marked C in cab enclosure panel (1).
- 3-5. Locate, mark, and drill two 0.196-in. diameter holes marked B in cab enclosure panel (1).

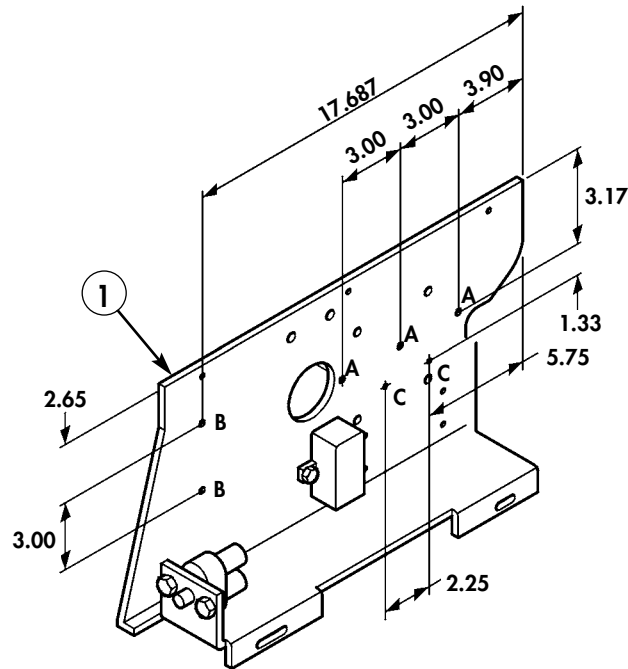

Figure 5-2.

Section IV. TERMINAL BOARD, COVER, AND LINK MODIFICATION

CAUTION

Do not cut raised sections of terminal board. Terminal board is not usable if cut on raised section.

- 4-1. Measure and cut terminal board (1) in two places (2). Remove burrs and sharp edges.
- 4-2. Install five nut sleeves (5) in terminal board covers (3), (4), and (6) and secure with snaprings (7).

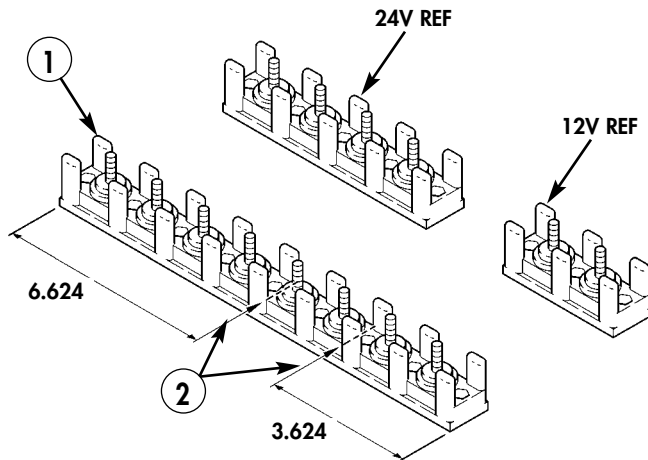

Figure 5-3.

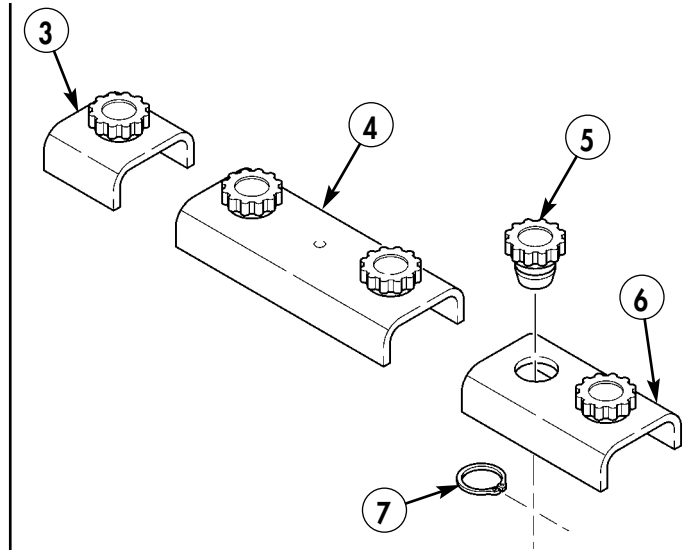

Figure 5-4.

1. TERMINAL BOARD – MS27212-3-8 – QTY. 1
3. TERMINAL BOARD COVER – 12480569-1 – QTY. 1
4. TERMINAL BOARD COVER – 12480569-2 – QTY. 1
6. TERMINAL BOARD COVER – MS18029-3S-2 – QTY. 1

Section V. B-BEAM PREPARATION

Locate, mark, and drill four 0.159-in. diameter holes (2) in B-beam (1).

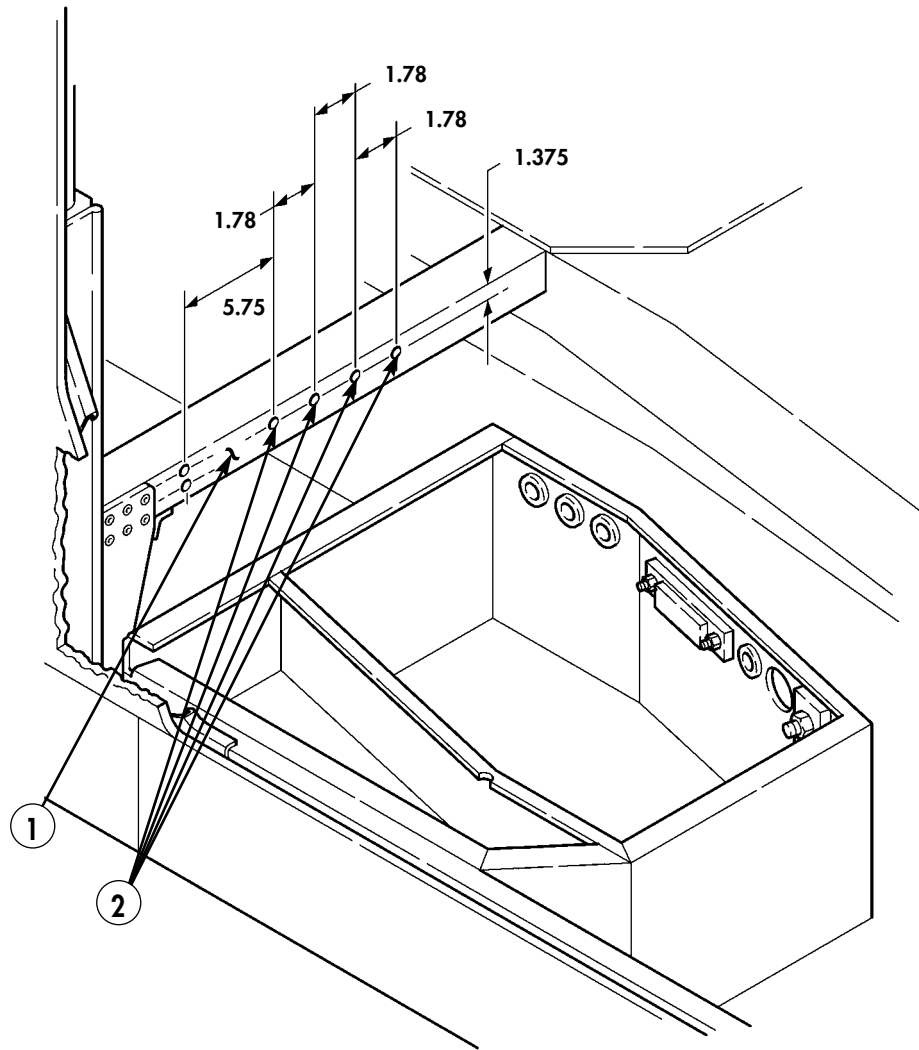
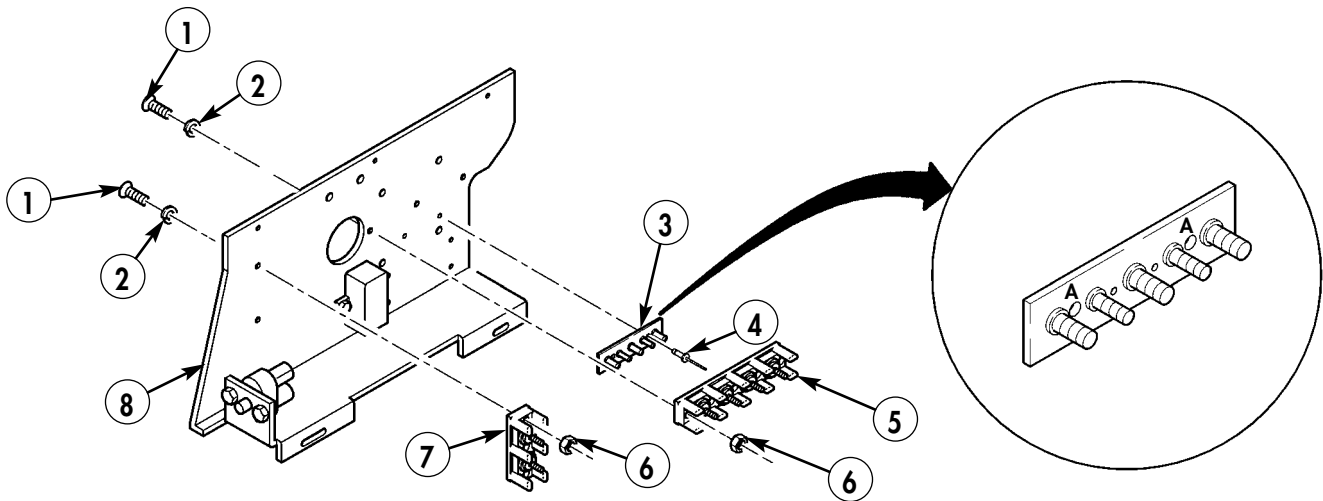

Figure 5-5.

Section VI. ASSEMBLY OF CAB ENCLOSURE PANEL

- 6-1. Install 12V terminal board (7) on enclosure panel (8) with two screws (1), lockwashers (2), and nuts (6).
- 6-2. Install 24V terminal board (5) on enclosure panel (8) with three screws (1), lockwashers (2), and nuts (6).
- 6-3. Enlarge two holes marked A in terminal board (3) to 0.196 in., and secure terminal board (3) to cab enclosure panel (8) with two rivets (4).



1. SCREW - MS35206-230 - QTY. 5
2. LOCKWASHER - MS35338-41 - QTY. 5
3. TERMINAL BOARD - 105A - QTY. 1
4. BLIND RIVET - 12339355-1 - QTY. 2
6. NUT - MS35649-63 - QTY. 5

Figure 5-6.

Section VII. FINAL ASSEMBLY, TERMINAL BOARD WIRING, AND TERMINAL LINK

NOTE

Perform steps 7-1 and 7-2 if hole does not exist in battery box.

- 7-1. Locate, mark, and drill one 2.00-in. diameter hole (6) in upper right corner of rear wall of battery box (9).
- 7-2. Install rubber grommet (7) in hole (6).
- 7-3. Secure terminal link (2) and fuse wire (3) to 12V terminal board (1) with two locknuts (4), and install terminal board cover (5).
- 7-4. Route 11.00-in. wire (8) through battery box hole (6).

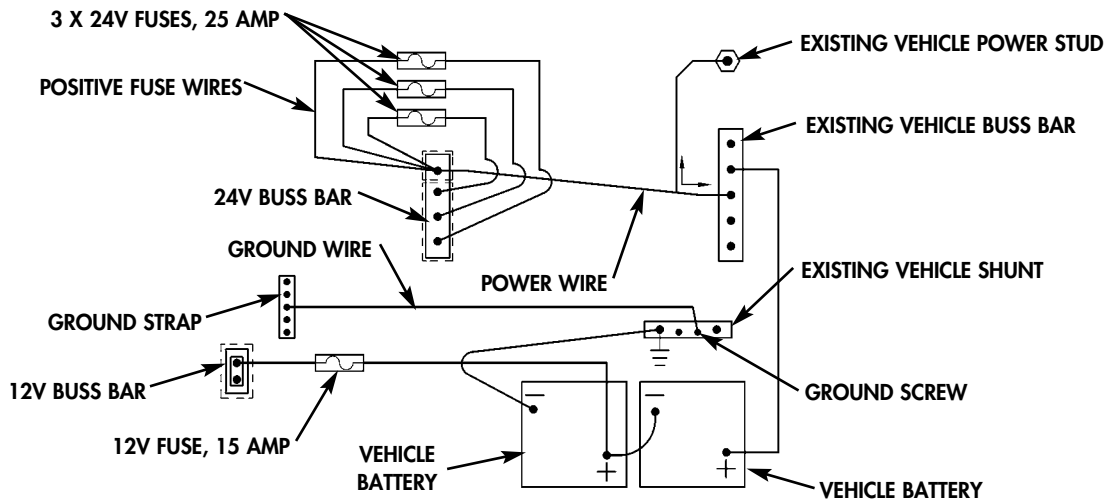
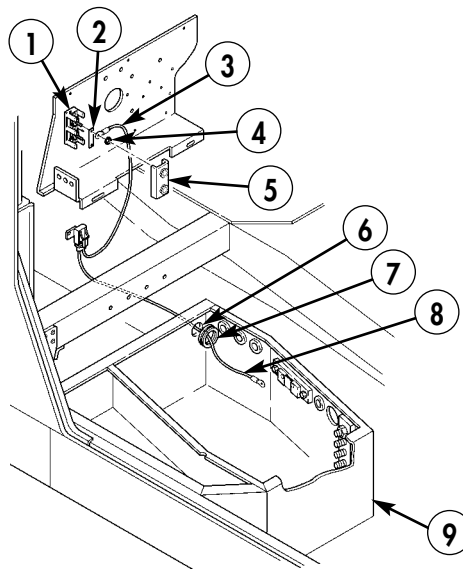

Figure 5-7.



2. TERMINAL LINK - MS25226-6N-2 - QTY. 1
3. FUSE WIRE ASSEMBLY (12V) - 12480568-2 - QTY. 1
4. LOCKNUT - 271175 - QTY. 2
5. TERMINAL BOARD COVER - MS18029-3S-2 - QTY. 1
7. GROMMET - 2400 - QTY. 1

Figure 5-8.

- 7-5. Connect wire (8) to existing positive 12V battery terminal end (11) with existing screw (10) and nut (12).

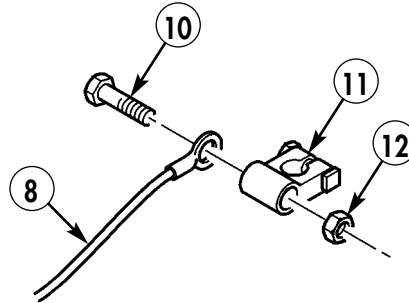
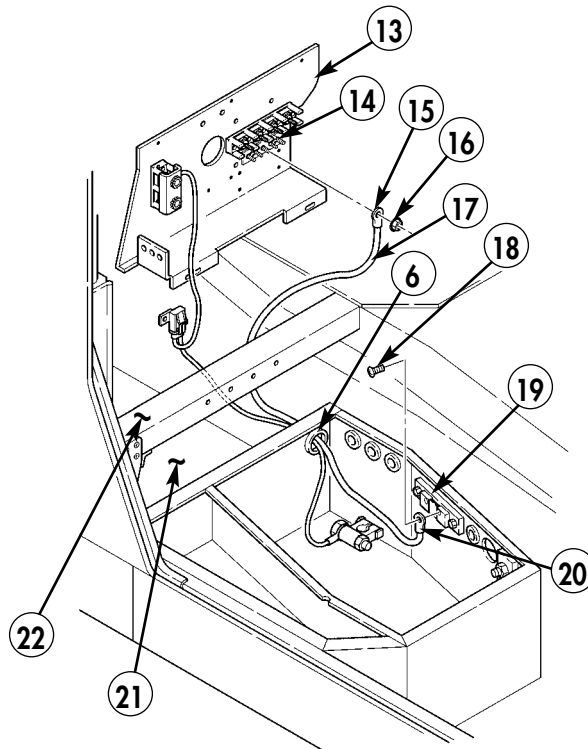

Figure 5-9.

- 7-6. Position cab enclosure panel (13) in rear floor pan (21) and rear of B-beam (22). Do not secure cab enclosure panel (13) at this time.
- 7-7. Route ground cable (17) through battery box hole (6).
- 7-8. Secure terminal lug (15) to center terminal of terminal board (14) with nut (16), and secure terminal lug (20) to shunt (19) with existing screw (18).
- 7-9. Install four additional nuts (16) on terminal board (14).



16. PLAIN-ASSEMBLED NUT – 271169 – QTY. 5
 17. GROUND CABLE ASSEMBLY – 12480567-1 – QTY. 1

Figure 5-10.

- 7-10. Route 24V power cable (28) through hole (6) and install 24V power cable terminal lug (24) on inboard stud (23) of terminal board (29). Do not secure 24V power cable terminal lug (24) at this time.
- 7-11. Secure three fuse wires (26) and 24V power cable terminal lug (24) to inboard terminal board stud (23) with locknut (27).
- 7-12. Secure three remaining fuse wires (25) to corresponding studs on 24V terminal board (29) with three locknuts (27).

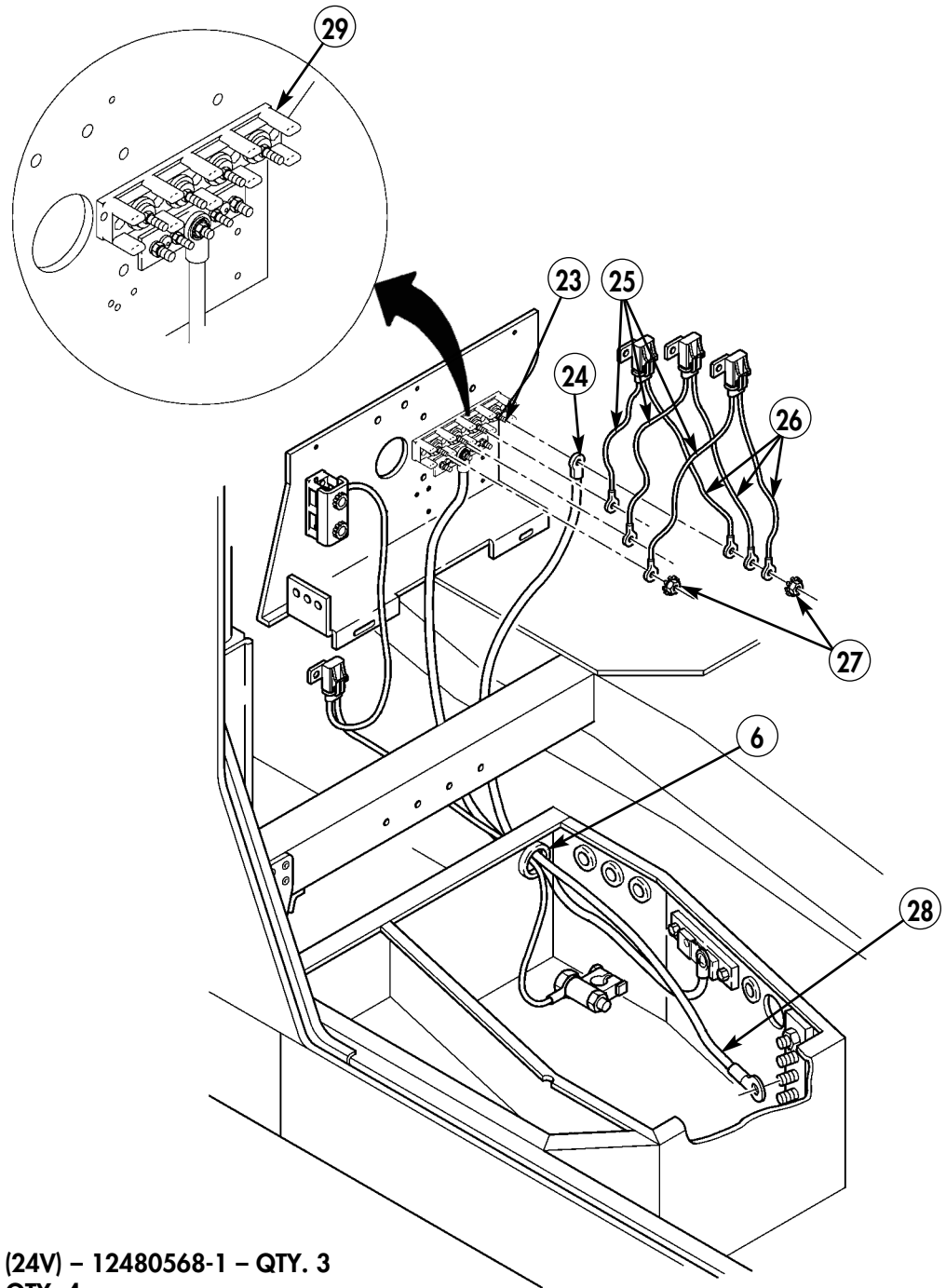

- 25. FUSE WIRE ASSEMBLY (24V) - 12480568-1 - QTY. 3
- 27. LOCKNUT - 271175 - QTY. 4
- 28. POWER CABLE ASSEMBLY - 12480567-2 - QTY. 1

Figure 5-11.

NOTE

For vehicles with new cab enclosure panel, begin with step 7-14.

- 7-13. Install cab enclosure panel (13). (Refer to TM 9-2320-280-20.)
- 7-14. Secure cab enclosure panel (13) to B-beam (22) with three self-tapping screws (30).
- 7-15. Secure cab enclosure panel (13) to battery box (34) with two capscrews (31), lockwashers (32), and washers (33).

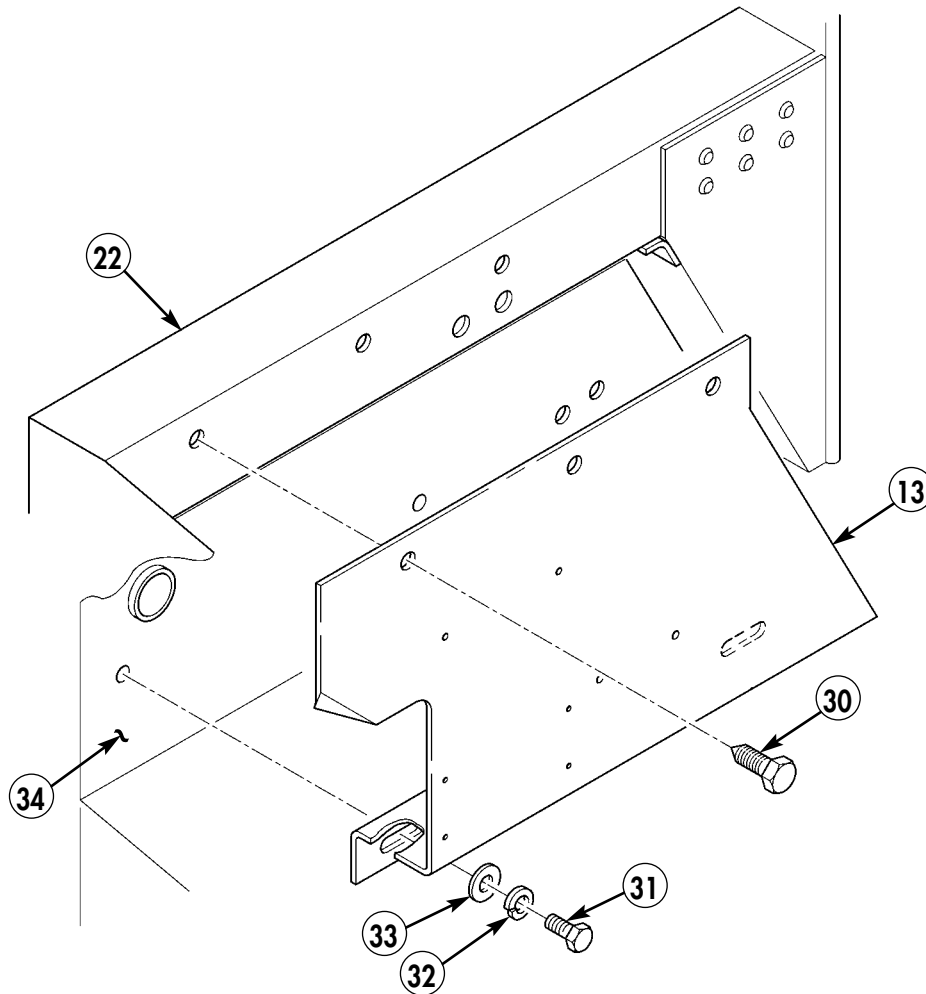

- 30. SELF-TAPPING SCREW - 12342499-2 - QTY. 3
- 31. CAPSCREW - B1821BH025C075N - QTY. 2
- 32. LOCKWASHER - MS35338-48 - QTY. 2
- 33. FLAT WASHER - MS51412-23 - QTY. 2

Figure 5-12.

- 7-16. Secure three 24V fuse wire assemblies (25) and one 12V fuse wire assembly (3) to B-beam (22) with four self-tapping screws (36).

NOTE

For models equipped with power stud, perform step 7-17.
Otherwise, proceed to step 7-18.

- 7-17. Secure 24V terminal board power wire terminal lug (28) to power stud (40) with lockwasher (38) and existing nut (39).
- 7-18. Secure 24V terminal board power wire terminal lug (28) to terminal board (37) with lockwasher (38) and existing nut (39).
- 7-19. Install decal (35) on B-beam (22).
- 7-20. If previously removed, install right-hand rear fixed door. (Refer to TM 9-2320-280-20.)
- 7-21. Install batteries. (Refer to TM 9-2320-280-20.)

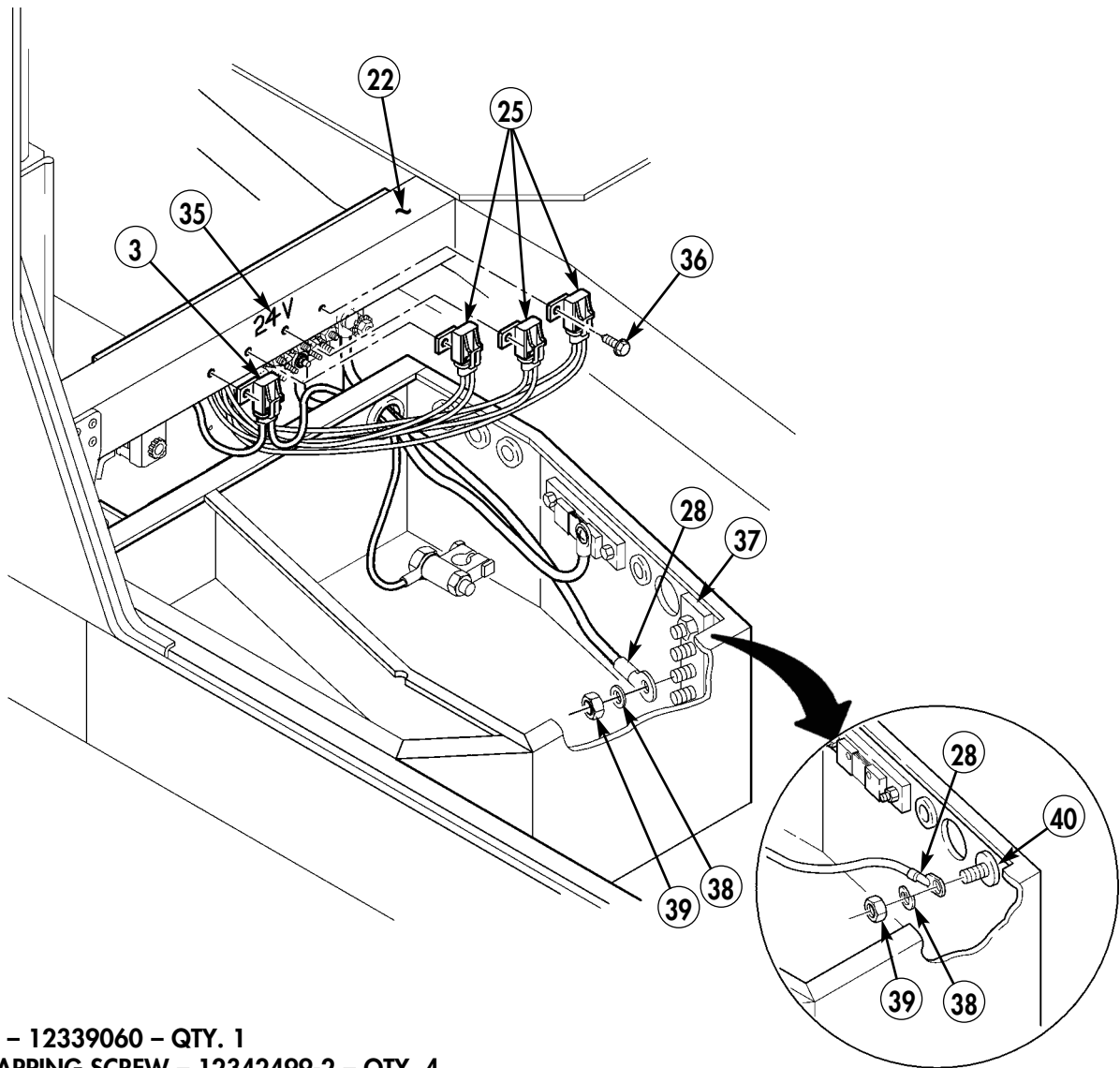

- 35. DECAL – 12339060 – QTY. 1
- 36. SELF-TAPPING SCREW – 12342499-2 – QTY. 4
- 38. LOCKWASHER – MS35338-48 – QTY. 1

Figure 5-13.

Section VIII. INTEGRATED RACK INSTALLATION

- 8-1. Remove two inserts (2) from bottom of integrated rack (1).

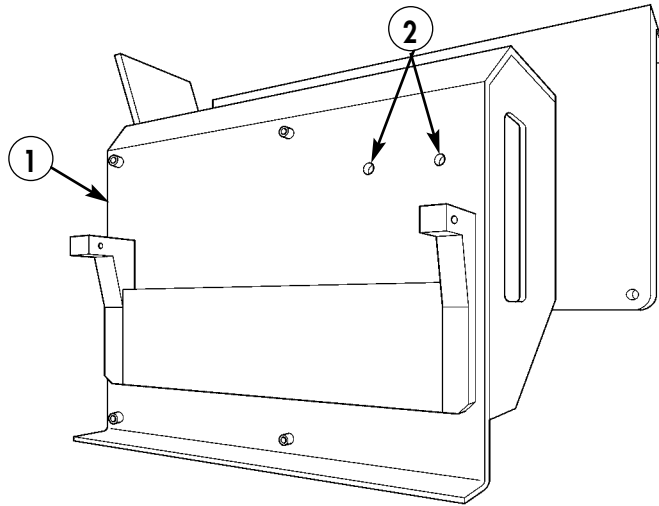

1. RACK, INTEGRATED – A3276903 – QTY. 1

Figure 5-14.

- 8-2. Using integrated rack (1) as template, locate, mark, and drill one 0.390-in. diameter hole (4) in dash (6).
- 8-3. Remove paint from vicinity of hole (4) and two existing inserts (5).
- 8-4. Install insert (3) in hole (4).
- 8-5. Apply anti-seize compound to vicinity of inserts (3) and (5) as required.

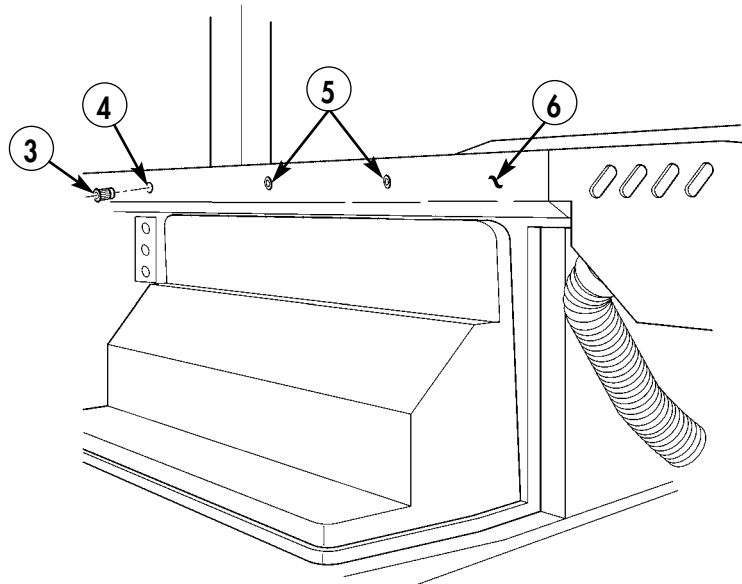

3. INSERT – 12446871-2 – QTY. 1

Figure 5-15.

- 8-6. Remove paint from vicinity of three mounting slots (7) on integrated rack (1).
- 8-7. Apply anti-seize compound to vicinity of three mounting slots (7) on integrated rack (1) as required.

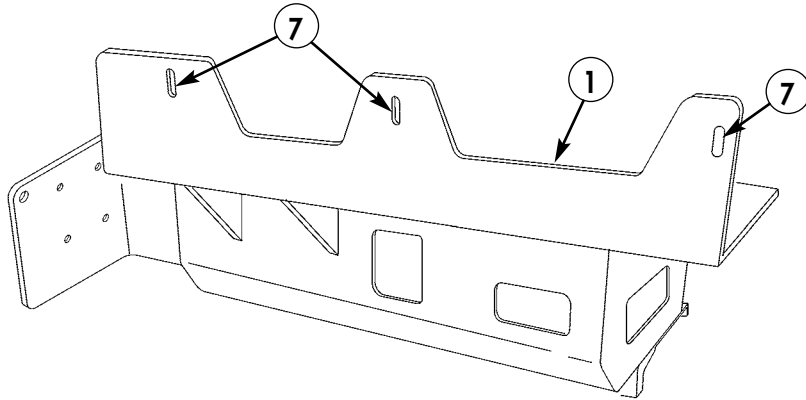
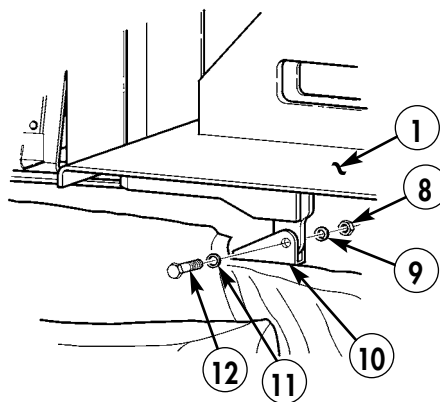

Figure 5-16.

NOTE

Do not install mounting hardware on top of integrated rack at this time. Not installing this hardware leaves the integrated rack free to pivot to assist in routing of cabling. Secure rack only after all cabling has been routed.

- 8-8. Mount integrated rack (1) to existing radio rack mount (10) using capscrew (12), washer (11), lockwasher (9), and nut (8). Repeat for opposite side. Do not tighten screws.



- 8. NUT – MS35649-2382 – QTY. 2
- 9. LOCKWASHER – MS35338-46 – QTY. 2
- 11. WASHER – 2436163 – QTY. 2
- 12. CAPSCREW – B1821BH038C225N – QTY. 2

Figure 5-17.

Section IX. INSTALLATION OF SINGARS MOUNTING TRAY AND AMP GUARD

- 9-1.** Remove paint from vicinity of four mounting holes (6) on integrated rack (7) and vicinity of four mounting holes (5) on bottom of mounting base (4).
- 9-2.** Apply anti-seize compound to vicinity of four mounting holes (6) on integrated rack and four mounting holes (5) on bottom of mounting base (4) as required.

NOTE

Two lockwashers and one nut are used on driver-side screws only.

- 9-3.** Install mounting base (4) and amp guard (9) on integrated rack (7) with two capscrews (2), four lockwashers (1), and two nuts (8). Secure MT-6352/VRC mounting base (4) on integrated rack (7) with two capscrews (3) and two lockwashers (1).
- 9-4.** Place warning decal (10) on amp guard (9).

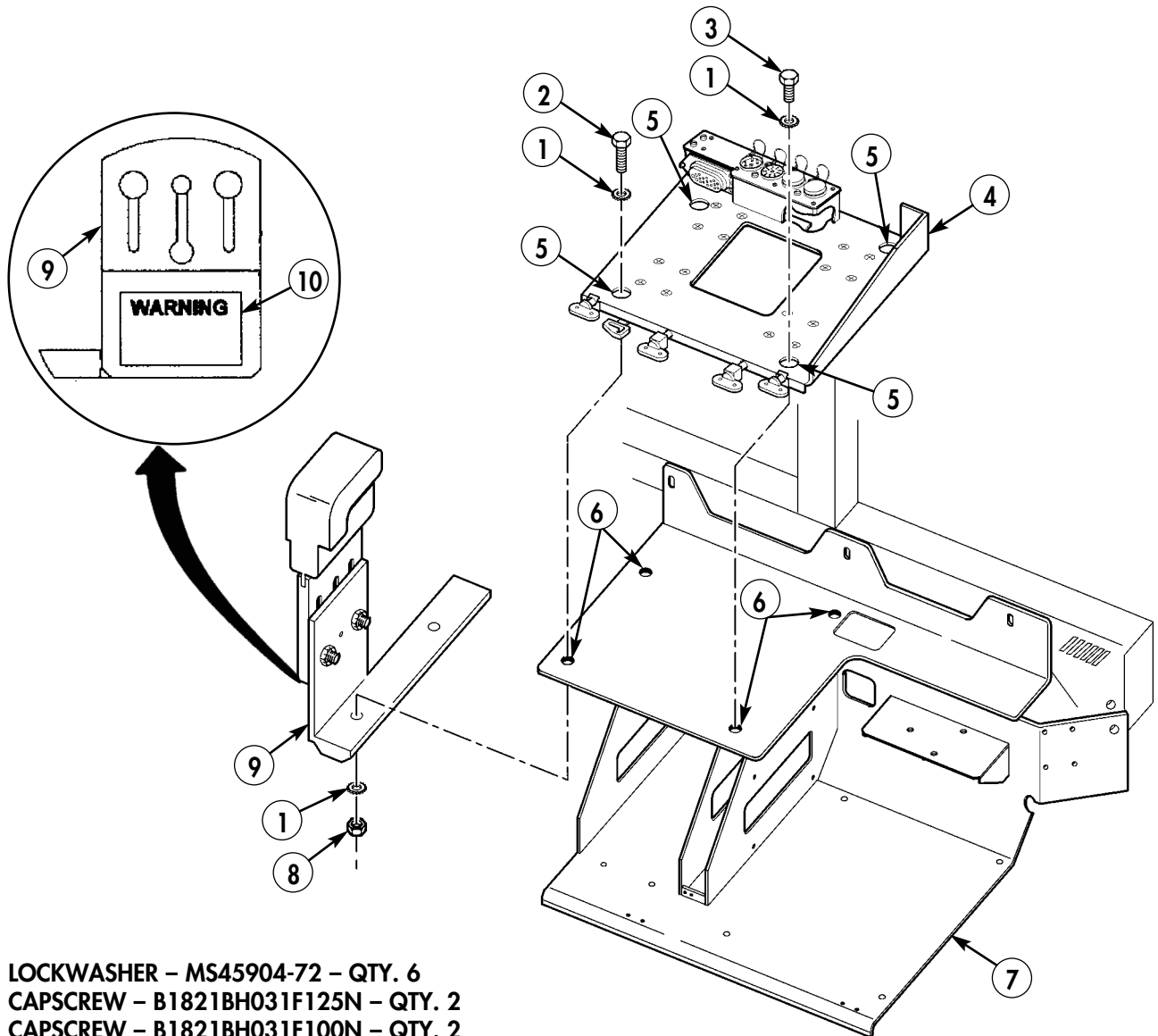

1. LOCKWASHER – MS45904-72 – QTY. 6
 2. CAPSCREW – B1821BH031F125N – QTY. 2
 3. CAPSCREW – B1821BH031F100N – QTY. 2
 4. MOUNTING BASE, MT-6352/VRC – A3013367-1 – QTY. 1
 8. NUT – MS51968-5 – QTY. 2
 9. AMP GUARD – 872842-1 – QTY. 1
 10. DECAL – 861868-2 – QTY. 1

Figure 5-18.

Section X. FRONT POWER AMPLIFIER INSTALLATION

- 10-1.** Remove paint from vicinity of four mounting areas (2) on MT-6353/VRC mounting base (1) and apply anti-seize compound as required.

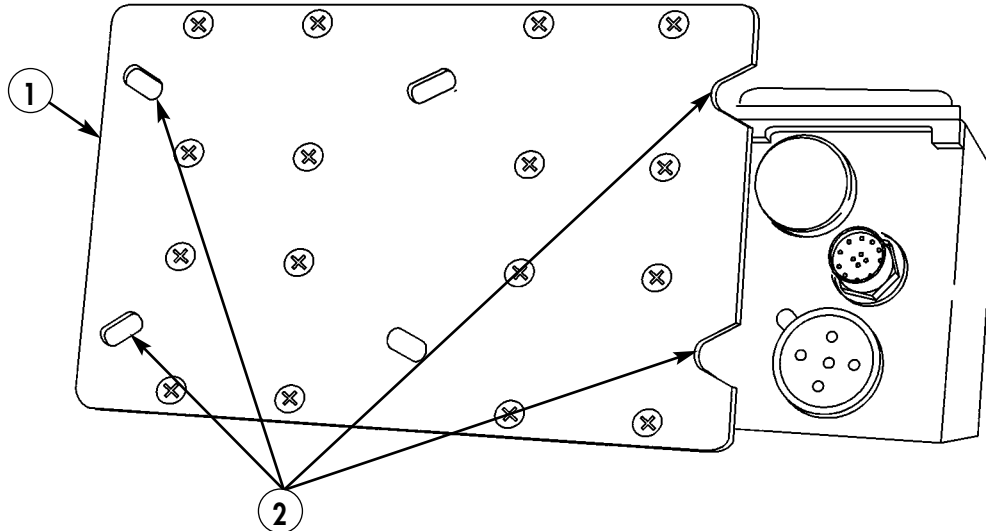

- 1. MOUNTING BASE, MT-6353/VRC – A3014053-1 – QTY. 1**

Figure 5-19.

- 10-2.** Remove paint from vicinity of four mounting holes (4) on integrated rack (3) and apply anti-seize compound as required.

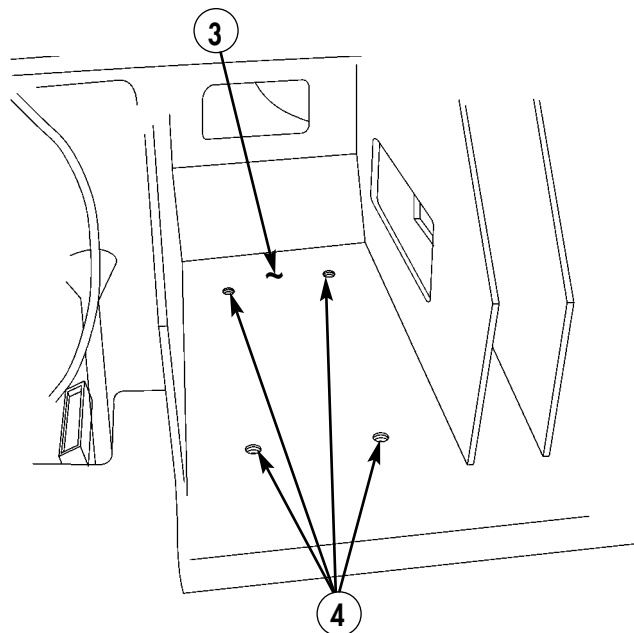
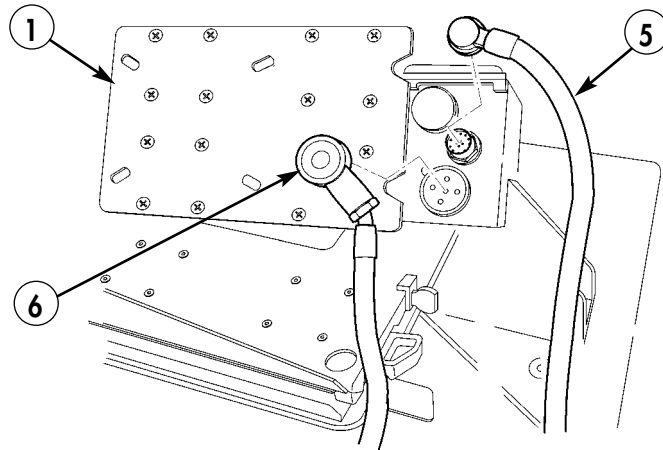

Figure 5-20.

- 10-3. Attach control cable (5) to MT-6353/VRC mounting base (1).
- 10-4. Attach power cable (6) to MT-6353/VRC mounting base (1).
- 10-5. Route cables (5) and (6) through hole in back of integrated rack (3).



- 5. CONTROL CABLE – A3210672-1 – QTY. 1
- 6. POWER CABLE – A3154857-1 – QTY. 1

Figure 5-21.

NOTE

Ensure control cable and power cable are routed through hole in back of integrated rack before installing MT-6353/VRC mounting base.

- 10-6. Attach MT-6353/VRC mounting base (1) to integrated rack (3) with four capscrews (9) and (10), four lockwashers (8), and nut strip (7).

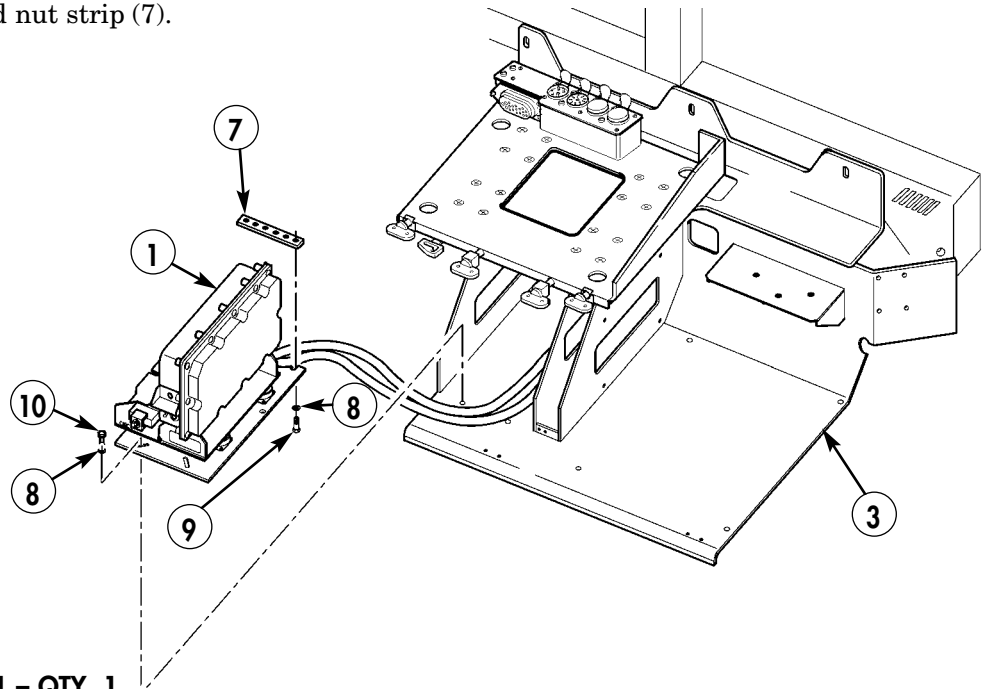

- 7. NUT STRIP – A3014064-1 – QTY. 1
- 8. LOCKWASHER – MS45904-72 – QTY. 4
- 9. CAPSCREW – B1821BH031F125N – QTY. 2
- 10. CAPSCREW – B1821BH031F075N – QTY. 2

Figure 5-22.

Section XI. FCB2 COMPONENTS INSTALLATION

NOTE

SINGGARS model AN/VRC-92F shown.

- 11-1. Remove paint from vicinity of holes (8) on integrated rack (7) and on both sides from vicinity of corresponding holes (10) on CPU isolation kit (4). Apply anti-seize compound as required.
- 11-2. Install CPU isolation kit (4) on integrated rack (7) with three capscrews (3), washers (2), and lockwashers (1), leaving open holes (8) and (10).
- 11-3. Install keyboard (9) in keyboard slot of integrated rack (7).
- 11-4. Install CPU (6) on CPU isolation kit (4) with two existing fastener guards (5).
- 11-5. Fabricate ground strap (13) from 8.00-in. length of braided wire and two terminal lugs.
- 11-6. Install ground strap (13) on CPU ground stud (17) with existing washer (14), lockwasher (15), and wingnut (16).
- 11-7. Install ground strap (13) on CPU isolation kit (4) and integrated rack (7), with capscrew (11), washer (2), and two lockwashers (12).

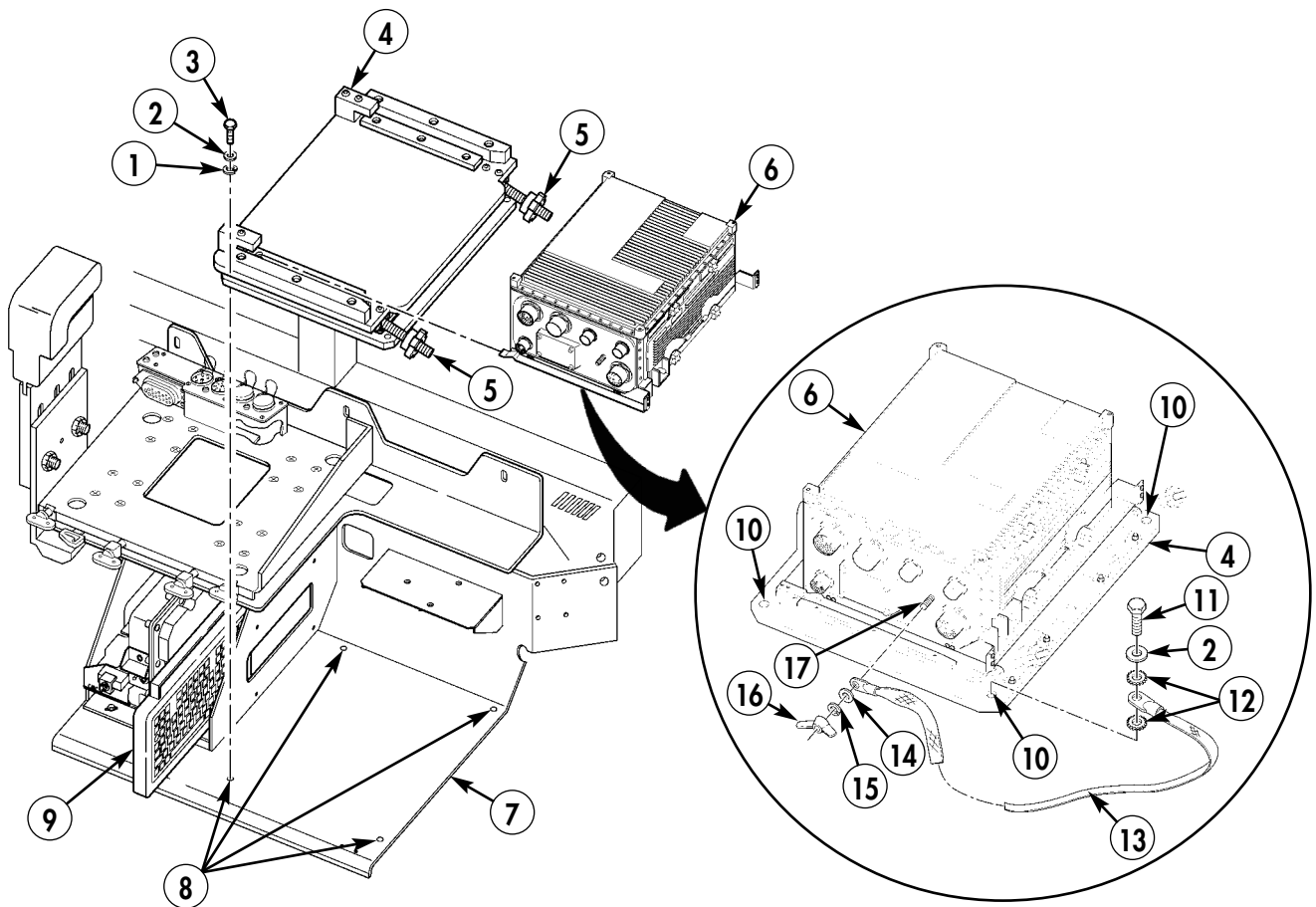

1. LOCKWASHER – MS35338-44 – QTY. 3
2. WASHER – 2436161 – QTY. 4
3. CAPSCREW – B1821BH025C100N – QTY. 3
4. CPU ISOLATION KIT – 872826-2 – QTY. 1
6. CPU – 881292-1 – QTY. 1

11. CAPSCREW – B1821BH025C125N – QTY. 1
12. LOCKWASHER – MS45904-68 – QTY. 2
13. CPU GROUND STRAP
 - BRAIDED WIRE – AA59569F30T0375 – QTY. A/R
 - TERMINAL LUG – MS20659-141 – QTY. 2

Figure 5-23.

- 11-8. Install ramball mount (26) on integrated rack (7) with two screws (25), screw (3), lockwasher (1), lanyard (18), washer (29), three lockwashers (1), and nuts (28).
- 11-9. Install display isolation kit (22) on display lock assembly (21) with four bolts (30), spacers (19), lanyard (18), and four wingnuts (20).
- 11-10. Install display unit (24) on display isolation kit (22) with four screws (23).
- 11-11. Install display lock assembly (21) on ramball mount (26).
- 11-12. Fabricate display ground strap (27) from 8-in. length of braided wire and two terminal lugs.

NOTE

Remove paint from vicinity of integrated rack mounting hole before performing step 11-13. Apply anti-seize compound as required. Ground strap will be installed on integrated rack only when integrated rack is fully secured in vehicle.

- 11-13. Install display ground strap (27) on display ground stud (33) with existing lockwasher (32) and wingnut (31).

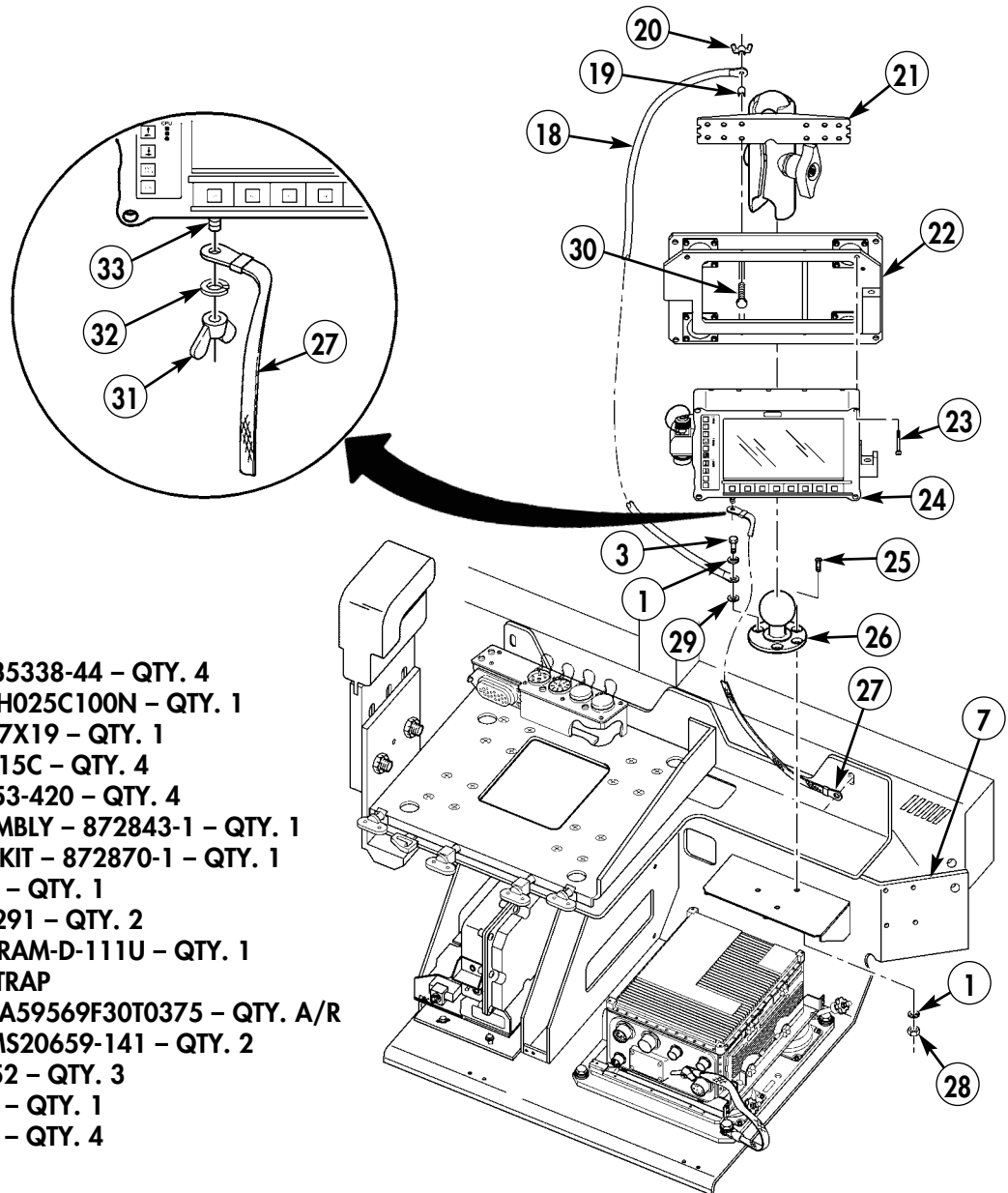

- 1. LOCKWASHER – MS35338-44 – QTY. 4
- 3. CAPSCREW B1821BH025C100N – QTY. 1
- 18. LANYARD – 8925T5-7X19 – QTY. 1
- 19. SPACER – 10705AL315C – QTY. 4
- 20. WINGNUT – MS51553-420 – QTY. 4
- 21. DISPLAY LOCK ASSEMBLY – 872843-1 – QTY. 1
- 22. DISPLAY ISOLATION KIT – 872870-1 – QTY. 1
- 24. DISPLAY – 881293-1 – QTY. 1
- 25. SCREW – MS35190-291 – QTY. 2
- 26. RAMBALL MOUNT – RAM-D-111U – QTY. 1
- 27. DISPLAY GROUND STRAP
 - BRAIDED WIRE – AA59569F30T0375 – QTY. A/R
 - TERMINAL LUG – MS20659-141 – QTY. 2
- 28. NUT – MS35649-2252 – QTY. 3
- 29. WASHER – 2436161 – QTY. 1
- 30. BOLT – MS35751-18 – QTY. 4

Figure 5-24.

Section XI.A. SERIAL INTERFACE ADAPTER DEVICE (SIAD) CABLES INSTALLATION

- 11.A-1. Install W3 cable (4) to SIAD (1).
- 11.A-2. Install W3N cable (2) to SIAD (1).
- 11.A-3. Install W3P cable (3) to SIAD (1).

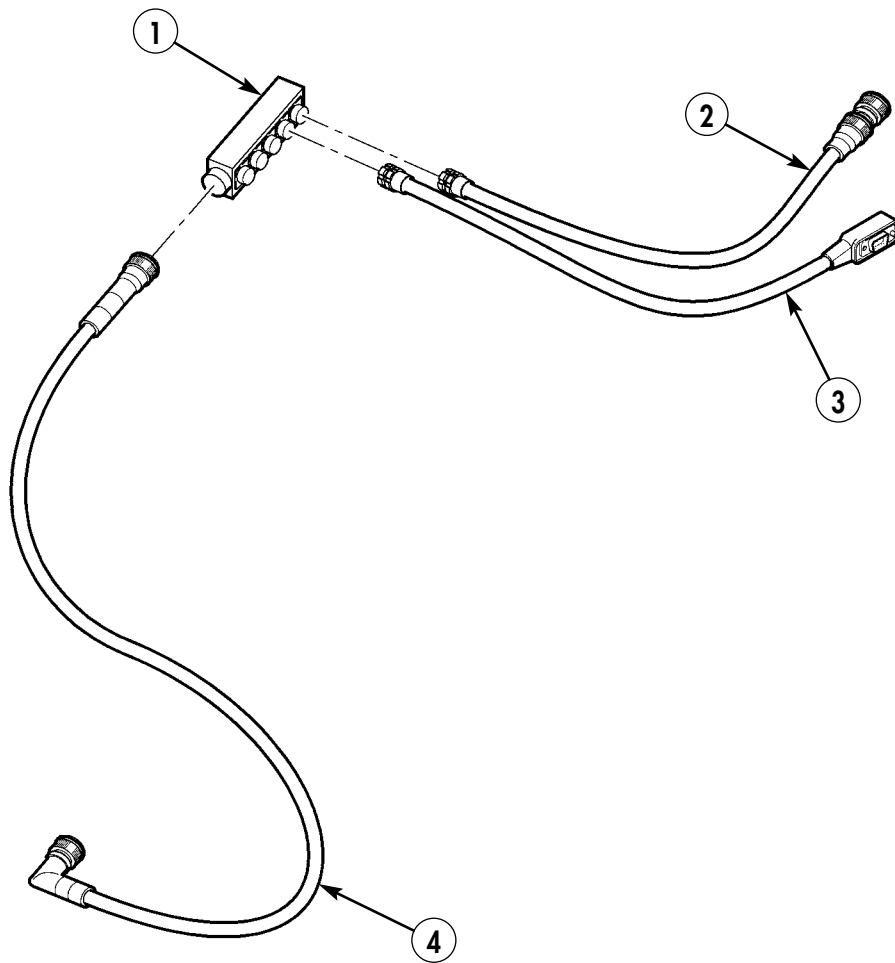

- 1. SERIAL INTERFACE ADAPTER DEVICE – 881331-1 – QTY. 1
- 2. W3N CABLE – 881336-1 – QTY. 1
- 3. W3P CABLE – 881335-1 – QTY. 1
- 4. W3 CABLE – P/O 881331-1 – QTY. 1

Figure 5-24.1

Section XI.B. SERIAL INTERFACE ADAPTER DEVICE (SIAD) INSTALLATION

Position SIAD (1) securely between FBCB2 (2) and keyboard tray (3) on integrated rack (4).

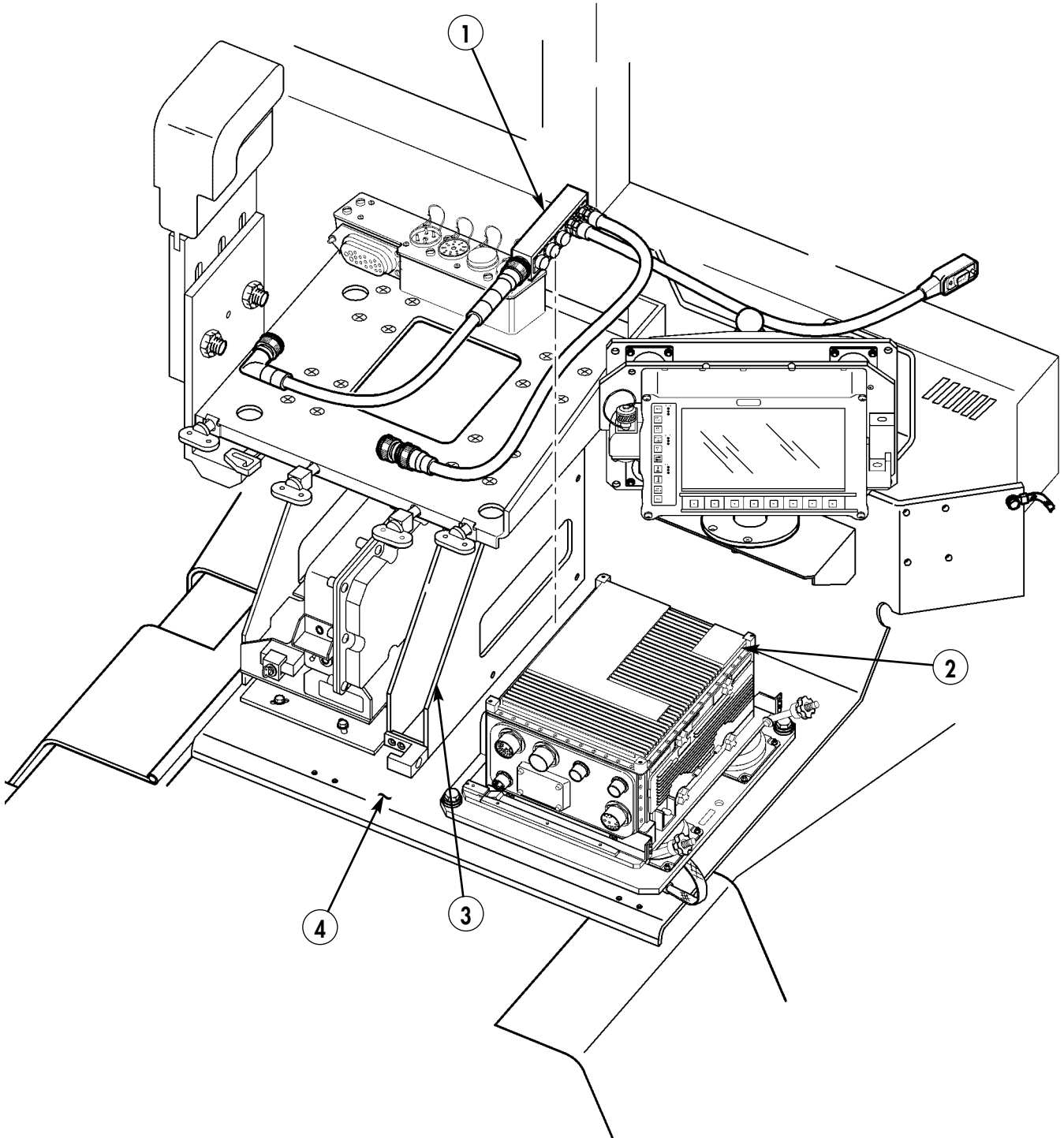
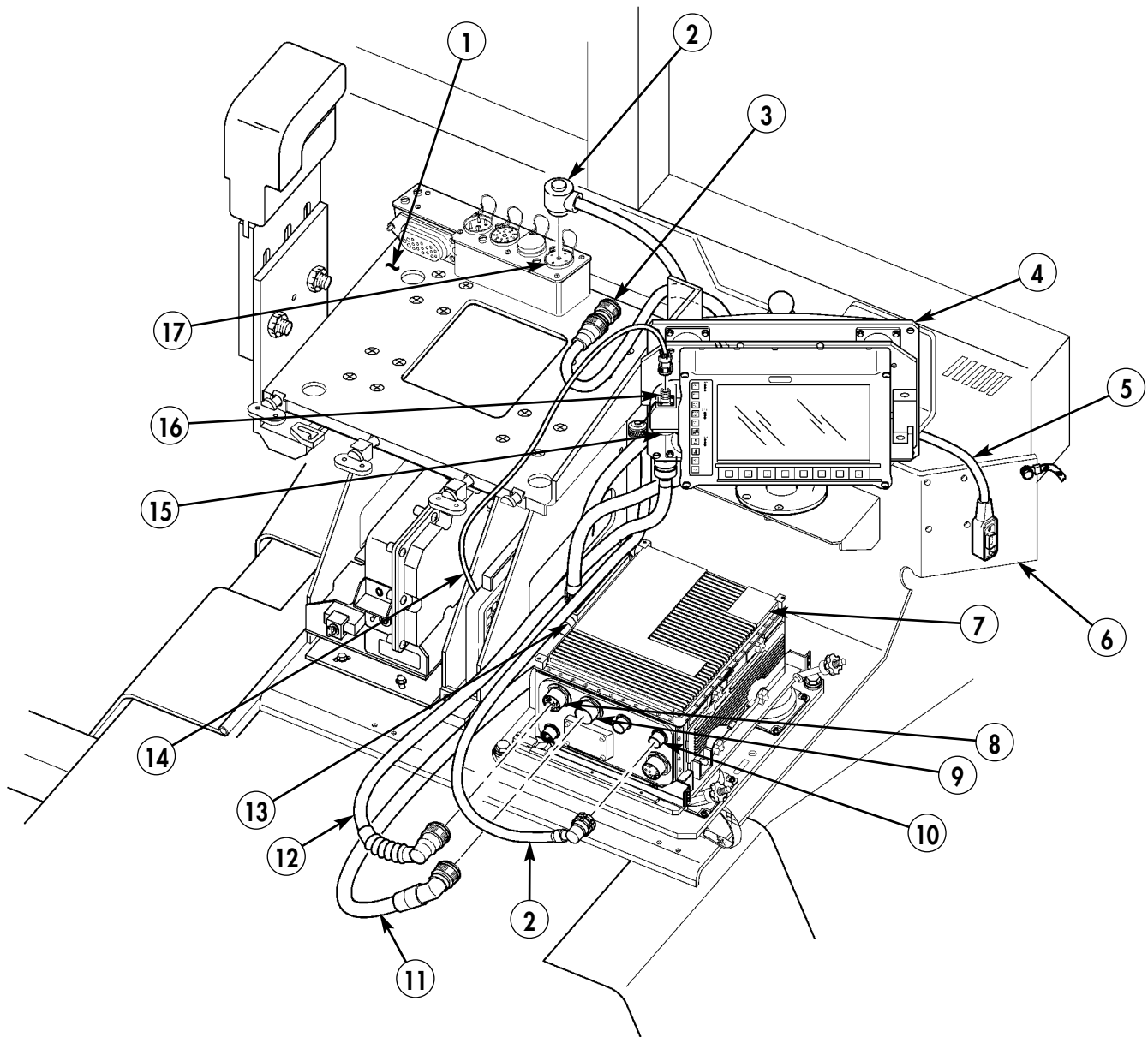

Figure 5-24.2.

Section XI.C. FBCB2 CABLES INSTALLATION

- 11.C-1. Connect W3 cable (11) from SIAD (13) to J3 connector (9) on FBCB2 processor (7).
- 11.C-2. Route W3P cable (5) from SIAD (13) to DAGR mount (6).
- 11.C-3. Connect W2 cable (12) to J4 connector (8) on FBCB2 processor (7) and J1 connector (15) on FBCB2 display unit (4).
- 11.C-4. Connect W1 cable (2) to J1 connector (10) on FBCB2 processor (7). Route W1 cable (2) to A4J2 connector (17).
- 11.C-5. Connect keyboard cable (14) to J2 connector (16) on FBCB2 display unit (4).
- 11.C-6. Route W1J1 cable (3) to SINCGARS mount (1).



- 2. W1 CABLE - 866003-3 - QTY. 1
- 12. W2 CABLE - 881327-1 - QTY. 1

Figure 5-24.3.

11.C-7. Install Vehicular Amplifier Adapter (VAA) (18) into SINCGARS mount (1).

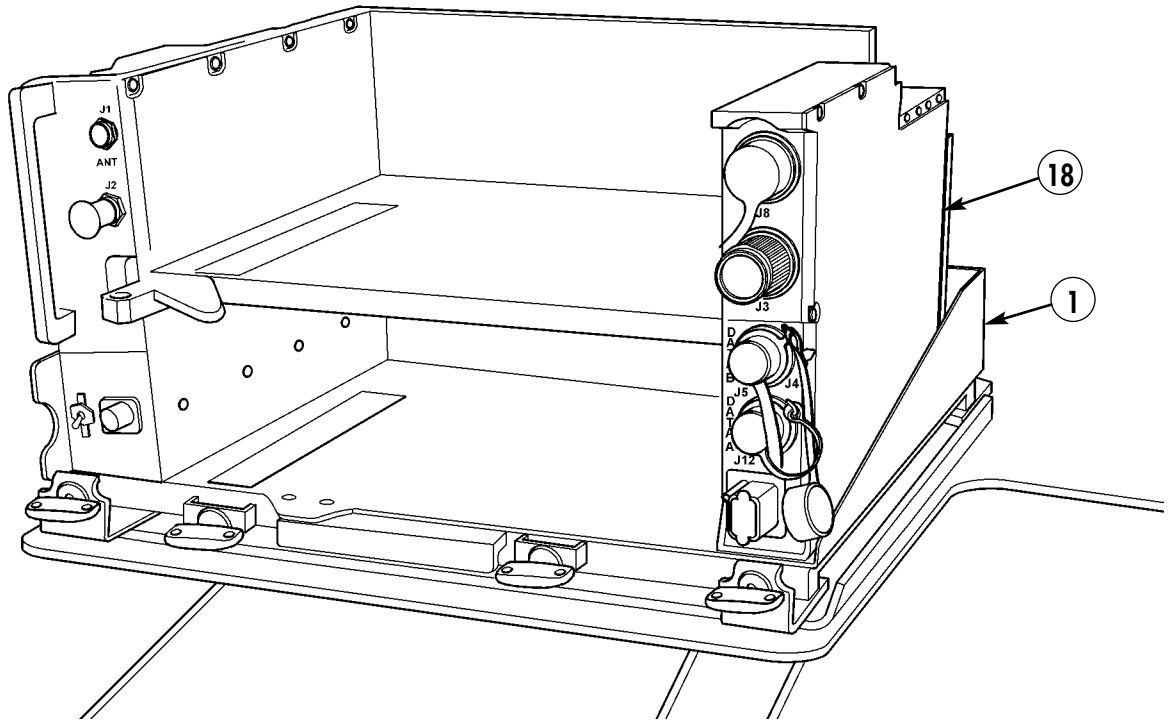

Figure 5-24.4.

11.C-8. Connect W3N cable (19) to J3 (20) connector on VAA (18).

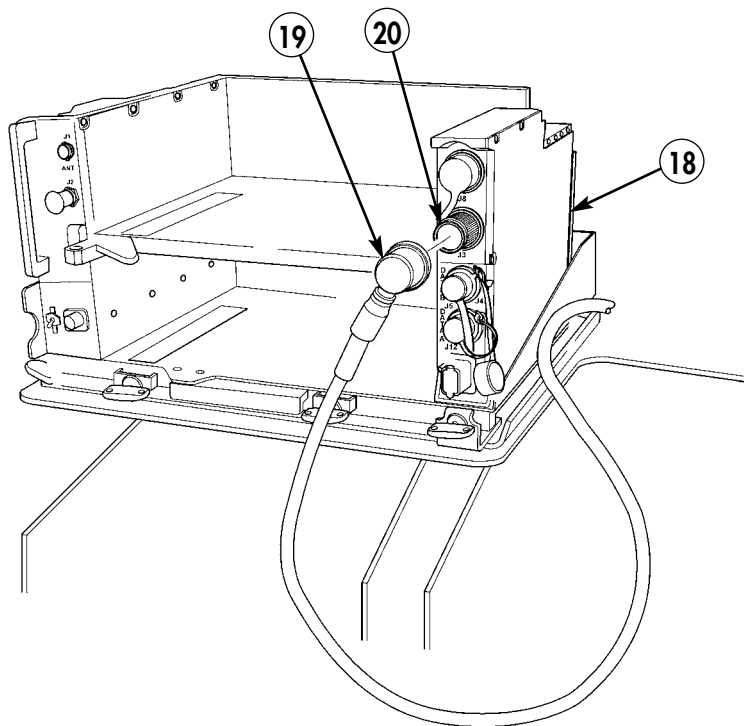

Figure 5-24.5.

Section XII. LOUDSPEAKER AND MULTI-NET RACK INSTALLATION

NOTE

Remove paint from vicinity of all mounting holes.

- 12-1.** Using four speaker mounting plates (3) as templates, locate, mark, and drill sixteen 0.281-in. diameter holes in lower shelf (4).

NOTE

- To ensure proper fit, keep mounting holes near outside edge of speaker mounting plate holes.
- Do not install screws in two far-left side mounting holes at this time. These holes align with the frame and require longer screws. These screws are installed in step 12-3.

- 12-2.** Install four speaker mounting plates (3) on lower shelf (4) with fourteen capscrews (1), twenty-eight washers (2), fourteen lockwashers (5), and nuts (6).

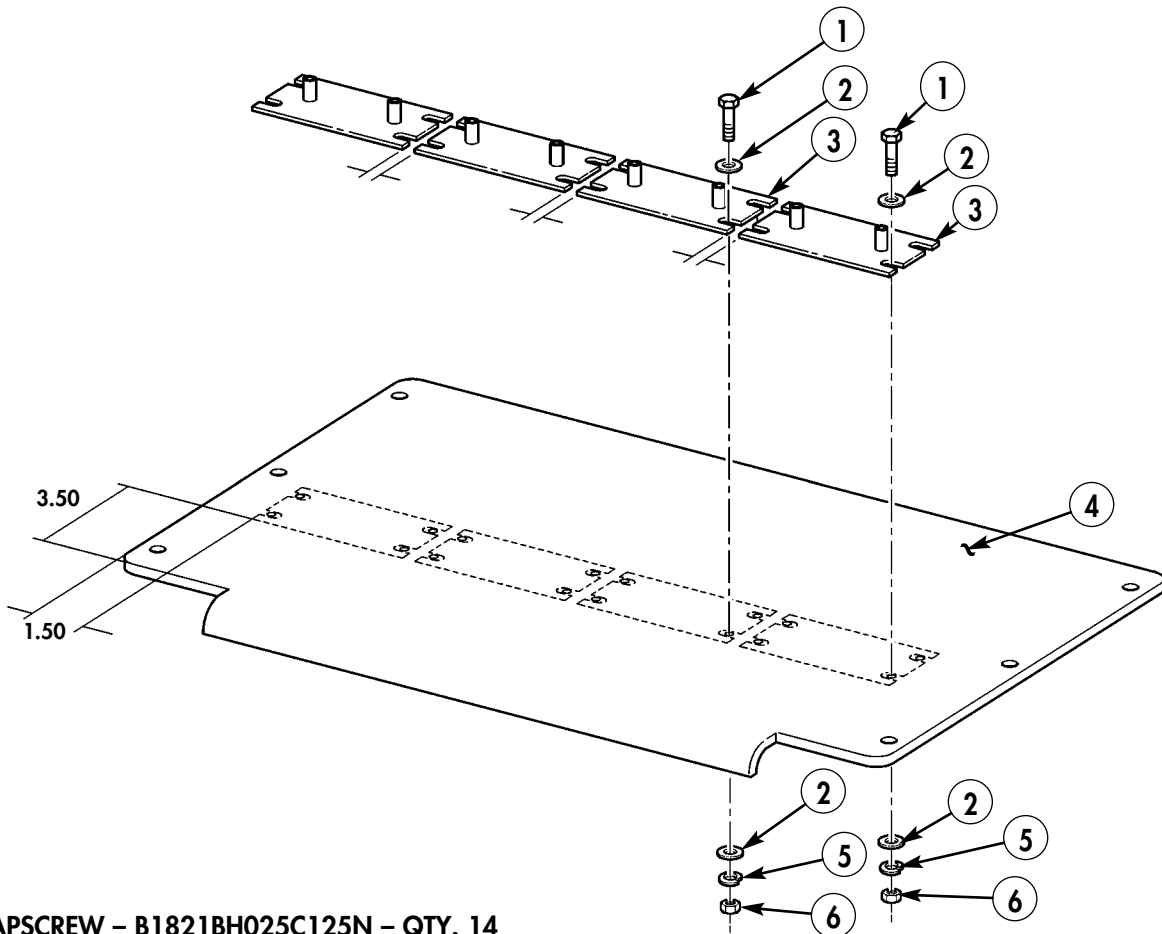

1. CAPSCREW – B1821BH025C125N – QTY. 14
2. WASHER – 2436161 – QTY. 28
3. MOUNTING PLATE – A3014550-1 – QTY. 4
5. LOCKWASHER – MS35338-44 – QTY. 14
6. NUT – 9419143 – QTY. 14

Figure 5-25.

NOTE

- Use existing holes of D-rings to mount frame and shelf. Older model trucks have existing strux nuts. If installing multi-net rack on a newer model vehicle, use locknuts.
- Any missing strux nuts must be replaced by locknuts.

- 12-3.** Install lower shelf (4) on frame (9) with two screws (22), four washers (19), two lockwashers (18), and nuts (17).
- 12-4.** Install lower shelf (4) and frame (9) on cargo bed (15) with two capscrews (21), lockwashers (20), spacers (16), and locknuts (14) if necessary.
- 12-5.** Install lower shelf (4) on frame (9) and cargo bed (15) with two capscrews (7), lockwashers (8), and locknuts (14) if necessary.
- 12-6.** Install frame (9) on cargo bed (15) with three capscrews (10), lockwashers (11), washers (12), spacers (13), and locknuts (14) if necessary.

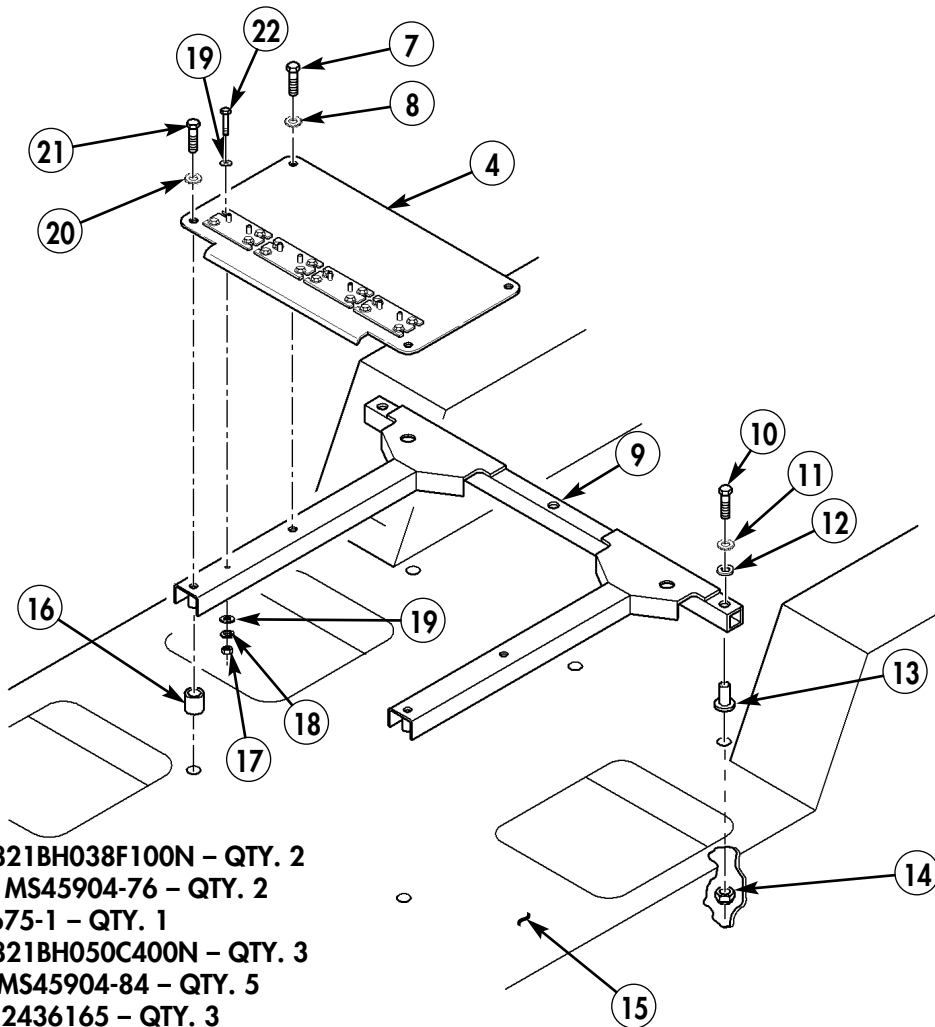

- 7. CAPSCREW – B1821BH038F100N – QTY. 2
- 8. LOCKWASHER – MS45904-76 – QTY. 2
- 9. FRAME – A3210675-1 – QTY. 1
- 10. CAPSCREW – B1821BH050C400N – QTY. 3
- 11. LOCKWASHER – MS45904-84 – QTY. 5
- 12. WASHER, FLAT – 2436165 – QTY. 3
- 13. SPACER – PART OF ITEM 9 – QTY. 3
- 16. SPACER – PART OF ITEM 9 – QTY. 2
- 17. NUT – 9419143 – QTY. 2
- 18. LOCKWASHER – MS35338-44 – QTY. 2
- 19. WASHER – 2436161 – QTY. 4
- 20. WASHER, FLAT – 2436165 – QTY. 2
- 21. CAPSCREW – B1821BH050C450N – QTY. 2

Figure 5-26.

- 12-7. Attach braces (26) to top shelf (25) with two screws (23), two lockwashers (24), and two nuts (30).
- 12-8. Attach side racks (29) to bottom shelf (25) with eight screws (23), eight lockwashers (24), and eight nuts (30).
- 12-9. Position top shelf (25) on side racks (29) and secure with eight screws (23), eight lockwashers (24), and eight nuts (30).
- 12-10. Secure braces (26) to bottom shelf (25) with two screws (27), four washers (28), and two nuts (31).

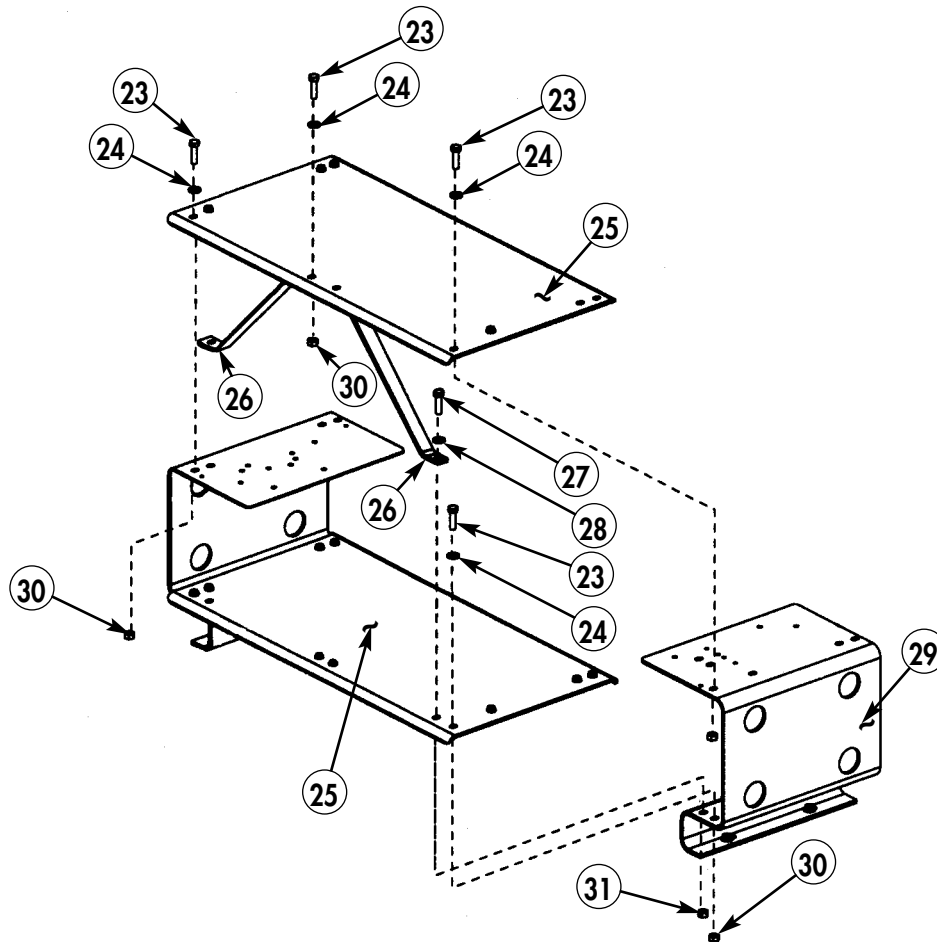

- 23. SCREW - MS90726-36 - QTY. 18
- 24. LOCKWASHER - MS45904-72 - QTY. 36
- 25. SHELF, ELECTRICAL - A3046236 - QTY. 2
- 26. BRACE - A3046237 - QTY. 1
- 27. SCREW - MS90725-8 - QTY. 2
- 28. WASHER - 2436161 - QTY. 4
- 29. BRACKET, RADIO RACK - A3046235 - QTY. 2
- 30. NUT - MS51967-5 - QTY. 18
- 31. NUT - MS51967-2 - QTY. 2

Figure 5-27.

NOTE

Remove paint from vicinity of all mounting holes. Apply anti-seize compound as required.

- 12-11. Install assembled multi-net rack (32) on frame (9) with four capscrews (34) and lockwashers (35).
- 12-12. Install grommet material (33) in eight holes of multi-net rack (32).
- 12-13. Install grommet material (36) in two holes of frame (9).

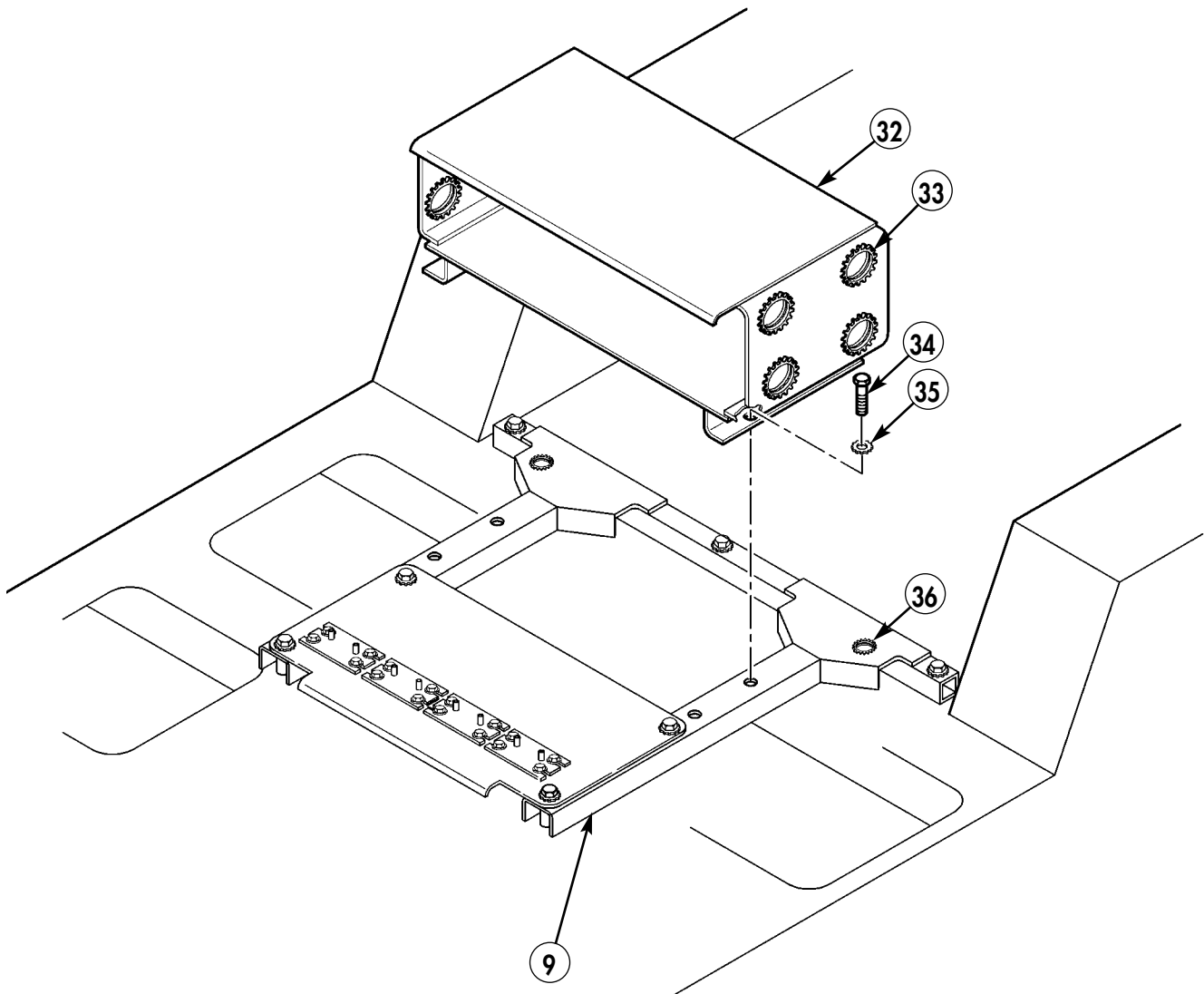

- 33. GROMMET MATERIAL – MS21266-6N – QTY. A/R
- 34. CAPSCREW – B1821BH038F100N – QTY. 4
- 35. LOCKWASHER – MS45904-76 – QTY. 4
- 36. GROMMET MATERIAL – MS21266-4N – QTY. A/R

Figure 5-28.

12-14. Install four loudspeakers (37) on speaker mounting plate (3) with eight existing externally relieved body screws (38).

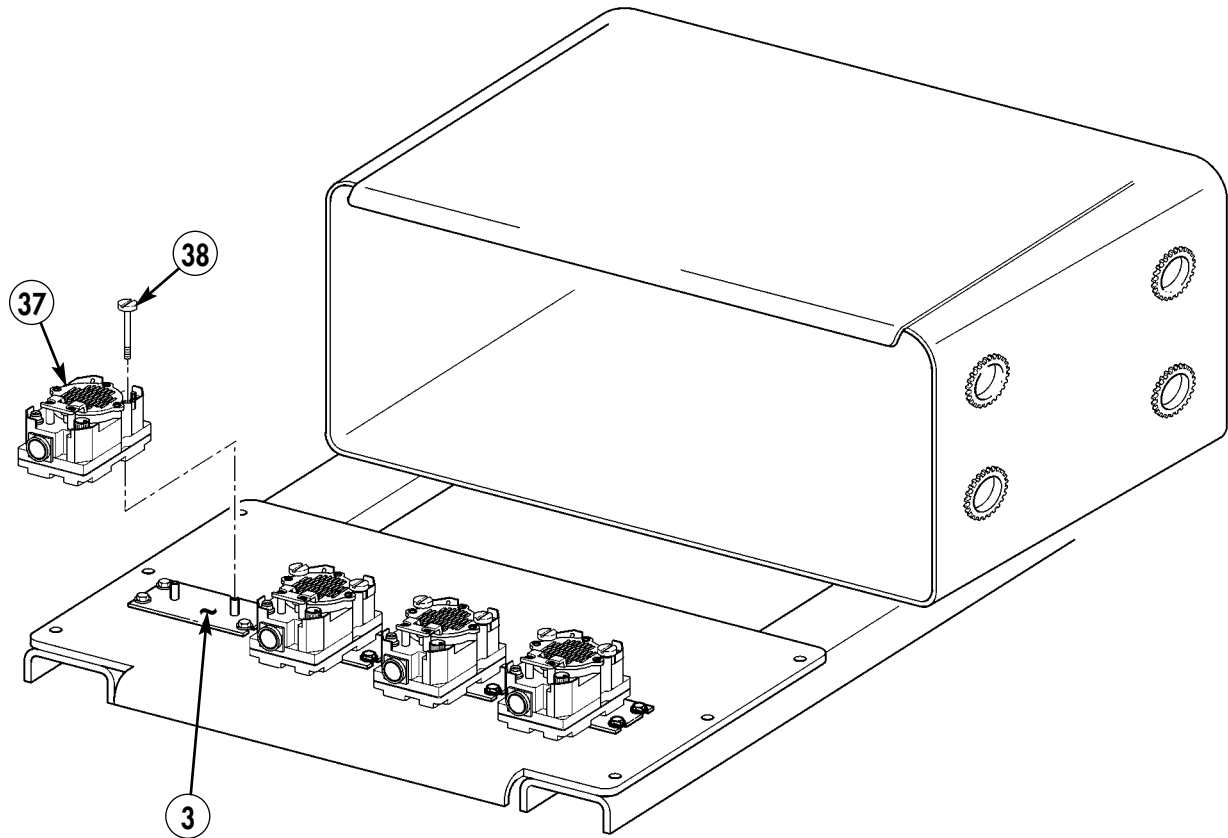

37. LOUDSPEAKER – A3014065-1 – QTY. 4

38. EXTERNALLY-RELIEVED BODY SCREW – P/O A3014065-1 – QTY. 8

Figure 5-29.

Section XIII. CHARGE CONTROL BOX INSTALLATION

- 13-1.** Locate, mark, and drill one 0.391-in. diameter hole (6) in multi-net rack (7).
- 13-2.** Using charge control box (4) as template, locate, mark, and drill three 0.391-in. diameter holes (8) in multi-net rack (7).
- 13-3.** Install four inserts (5) in multi-net rack (7).
- 13-4.** Install charge control box (4) on multi-net rack (7) with four screws (1), washers (2), and lockwashers (3).

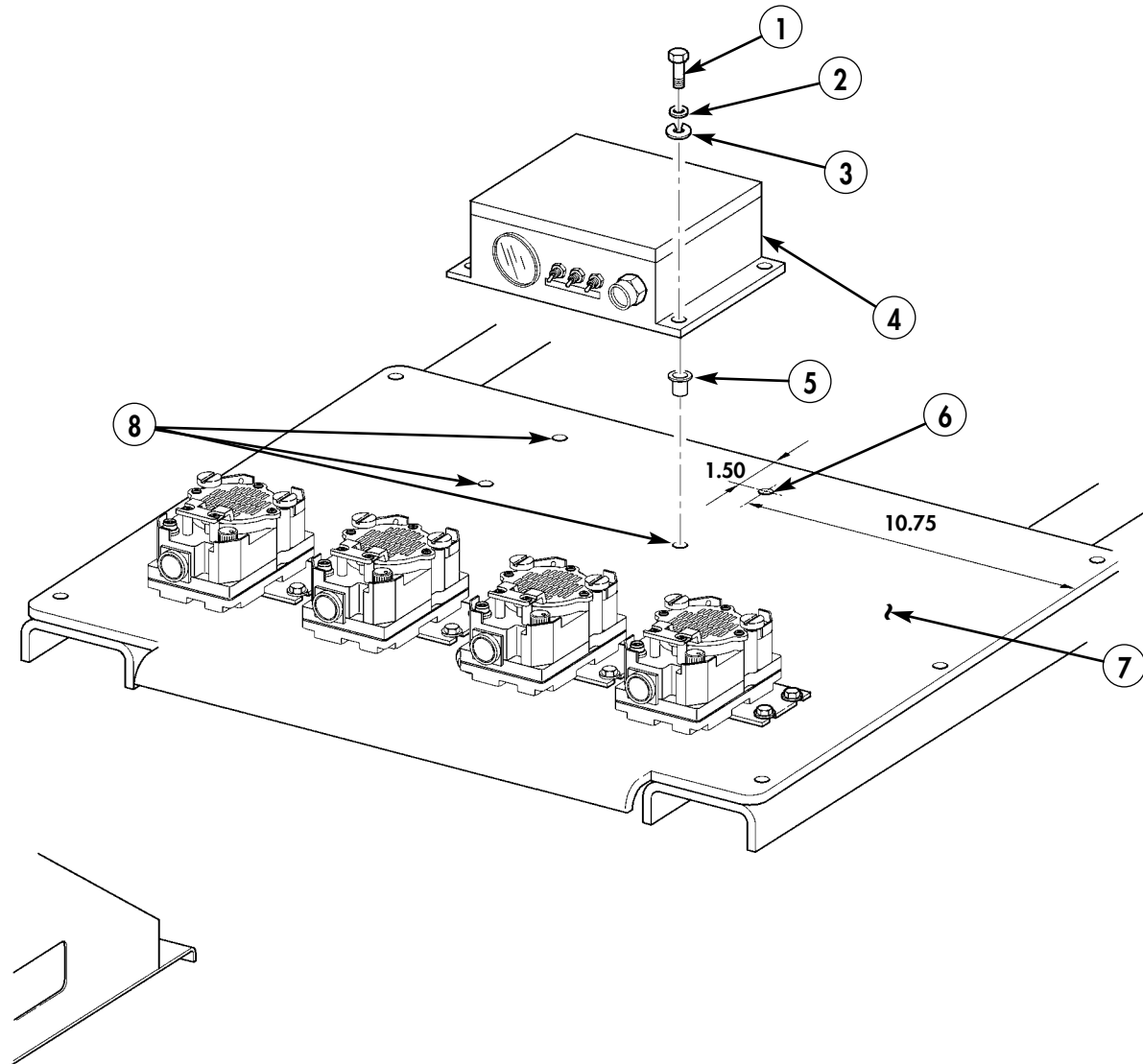

- 1. SCREW – B1821BH025C100N – QTY. 4**
2. WASHER – 2436161 – QTY. 4
3. LOCKWASHER – 120380 – QTY. 4
4. CHARGE CONTROL BOX – PKMM-000-002 – QTY. 1
5. INSERT – 12446871-2 – QTY. 4

Figure 5-30.

Section XIV. REAR SINGARS MOUNT INSTALLATION

14-1. Locate, mark, and drill one 0.343-in. diameter hole (2) in lower shelf of multi-net rack (1).

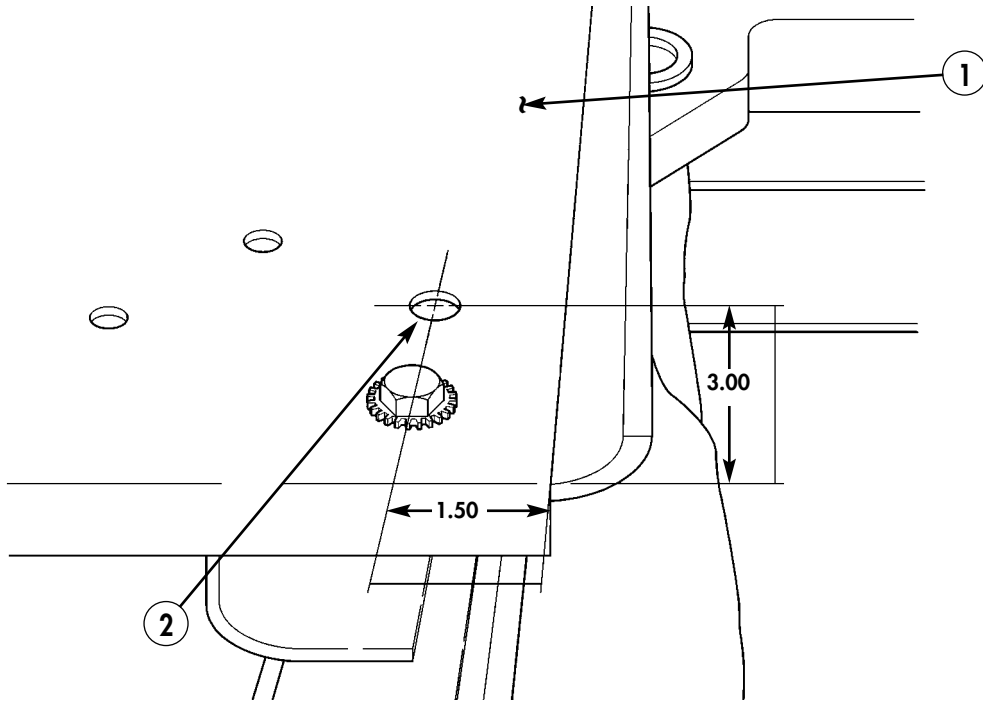

Figure 5-31.

14-2. Using SINGARS mounting base MT-6352/VRC as template, locate, mark, and drill four 0.343-in. diameter holes (3) in lower shelf of multi-net rack (1).

14-3. Remove paint from vicinity of holes (3) and apply anti-seize compound as required.

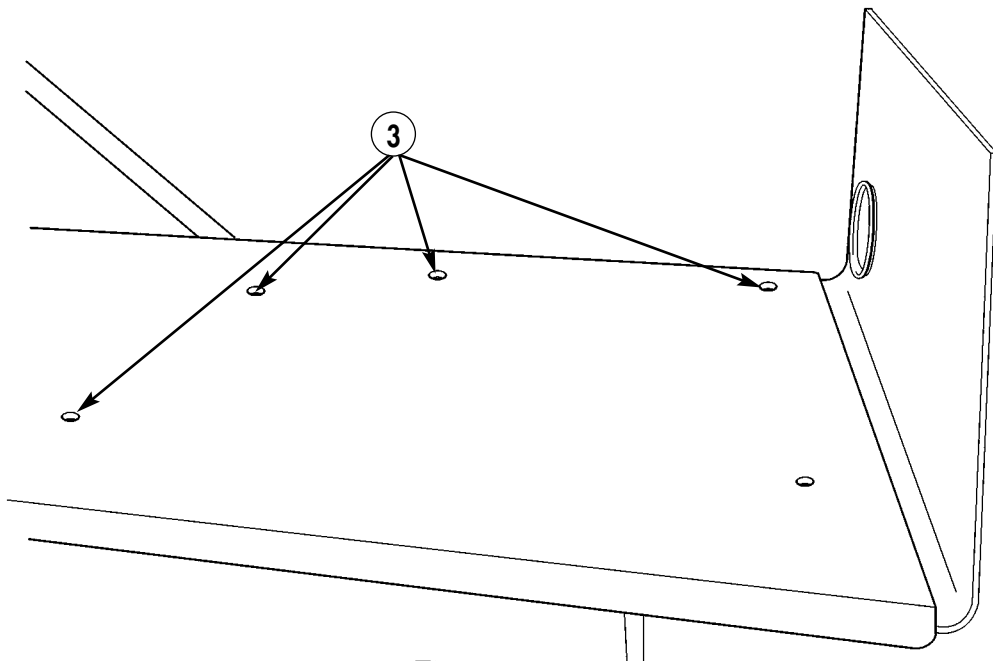
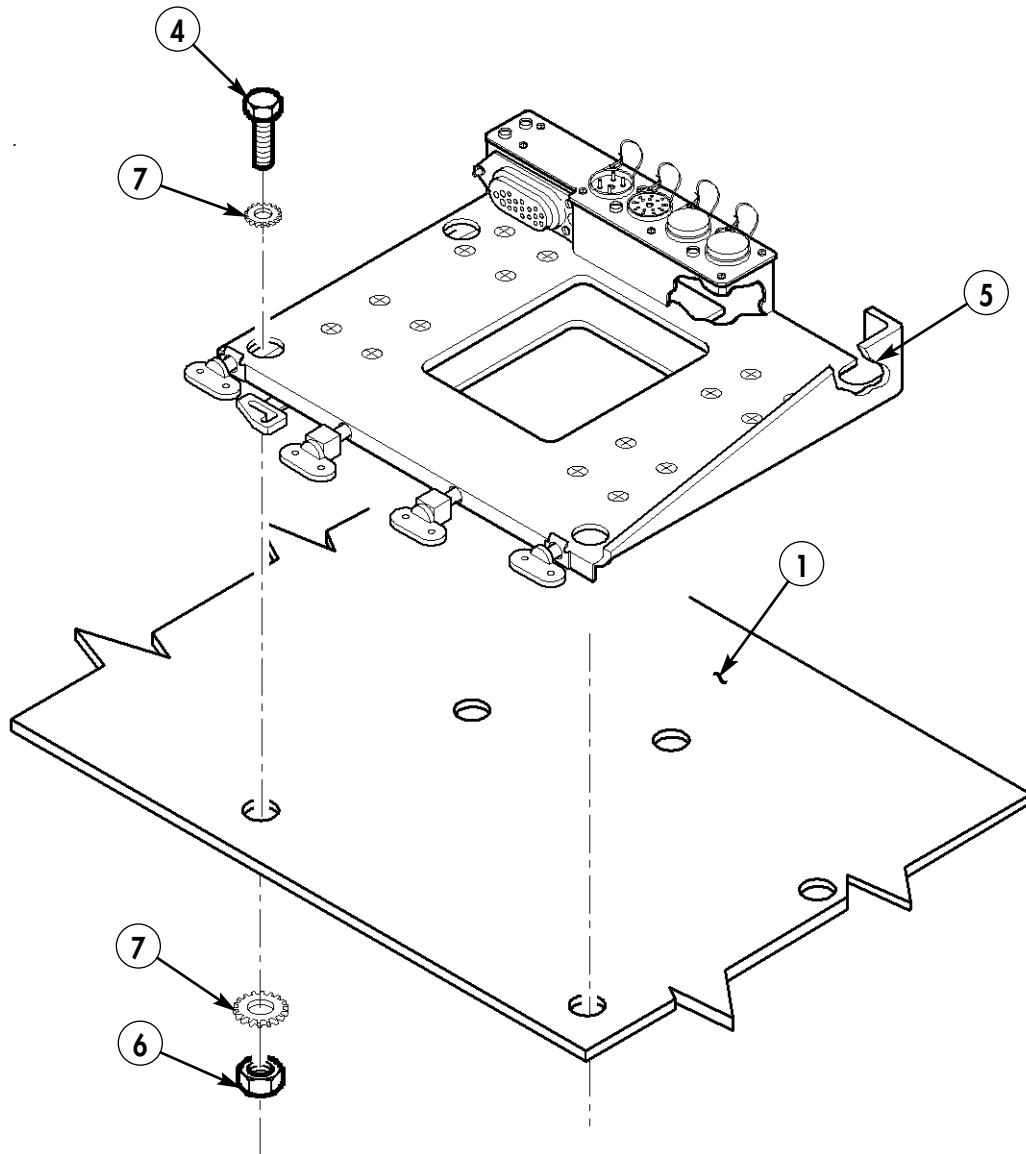

Figure 5-32.

- 14-4. Install SINCGARS mounting base MT-6352/VRC (5) on multi-net rack (1) using four capscrews (4), eight lockwashers (7), and four nuts (6).



4. CAPSCREW - B1821BH031F100N - QTY. 4
 5. MOUNTING BASE, MT-6352/VRC - A3013367-1 - QTY. 1
 6. NUT - MS51968-5 - QTY. 4
 7. LOCKWASHER - MS45904-72 - QTY. 8

Figure 5-33.

Section XV. REAR POWER AMPLIFIER INSTALLATION

15-1. Position power amp mounting base MT6353/VRC (2) on multi-net rack (1).

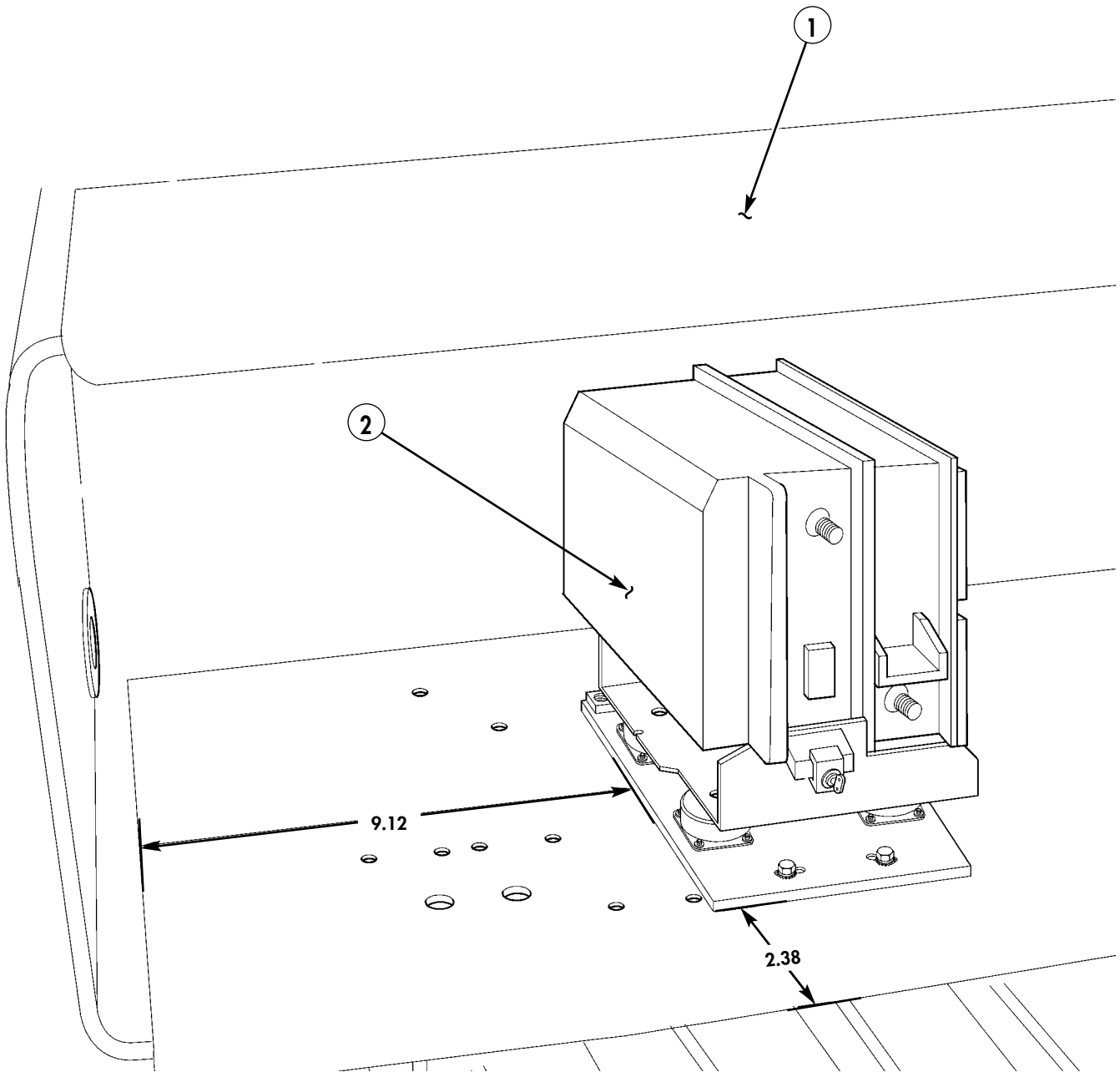

2. POWER AMP MOUNTING BASE, MT6353/VRC - A3014053-1 - QTY. 1

Figure 5-34.

15-2. Using power amp mounting base MT6353/VRC as template, locate, mark, and drill four 0.343-in. diameter holes (3). Remove paint and apply 12Z31001 anti-seize compound as required.

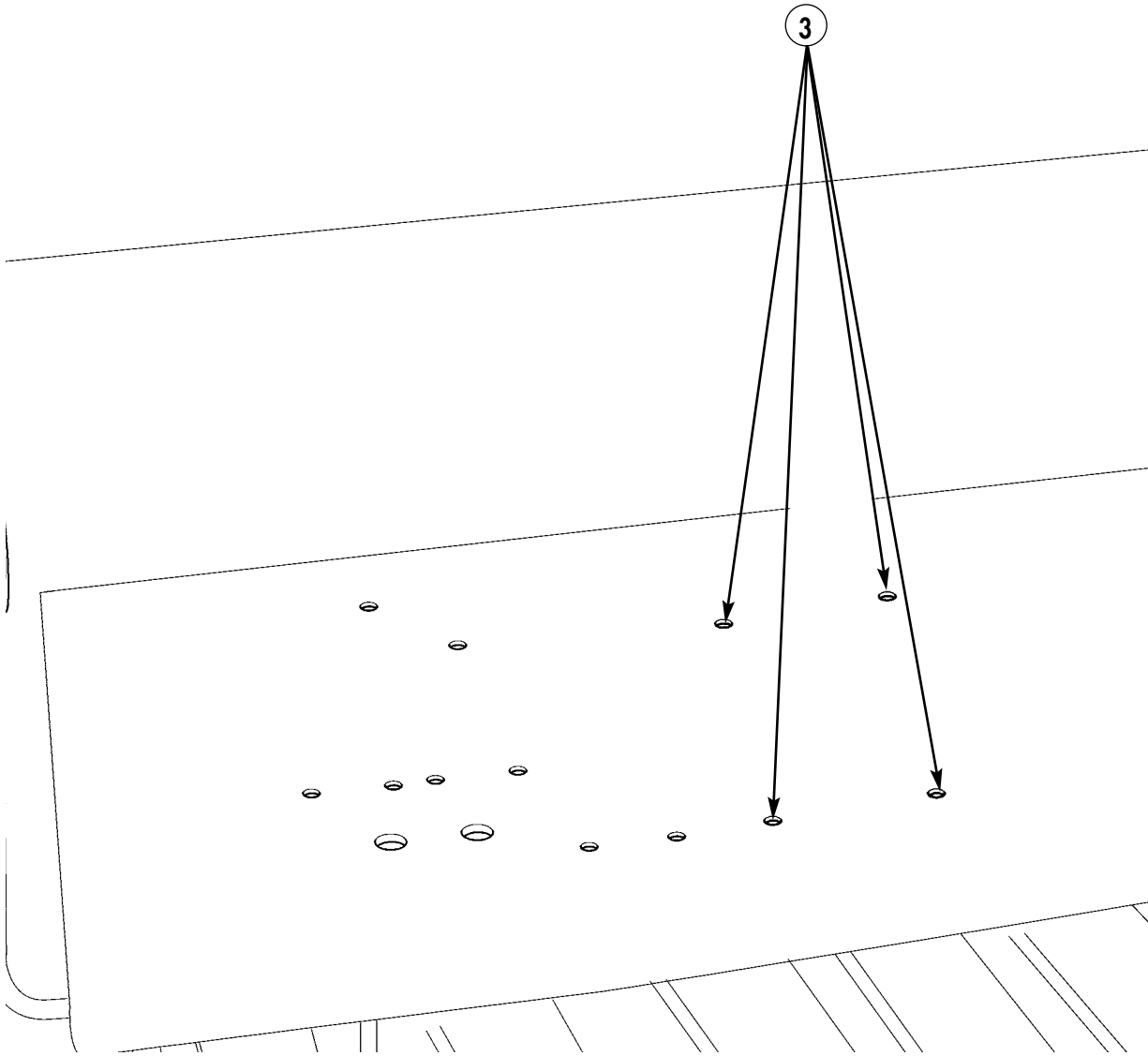
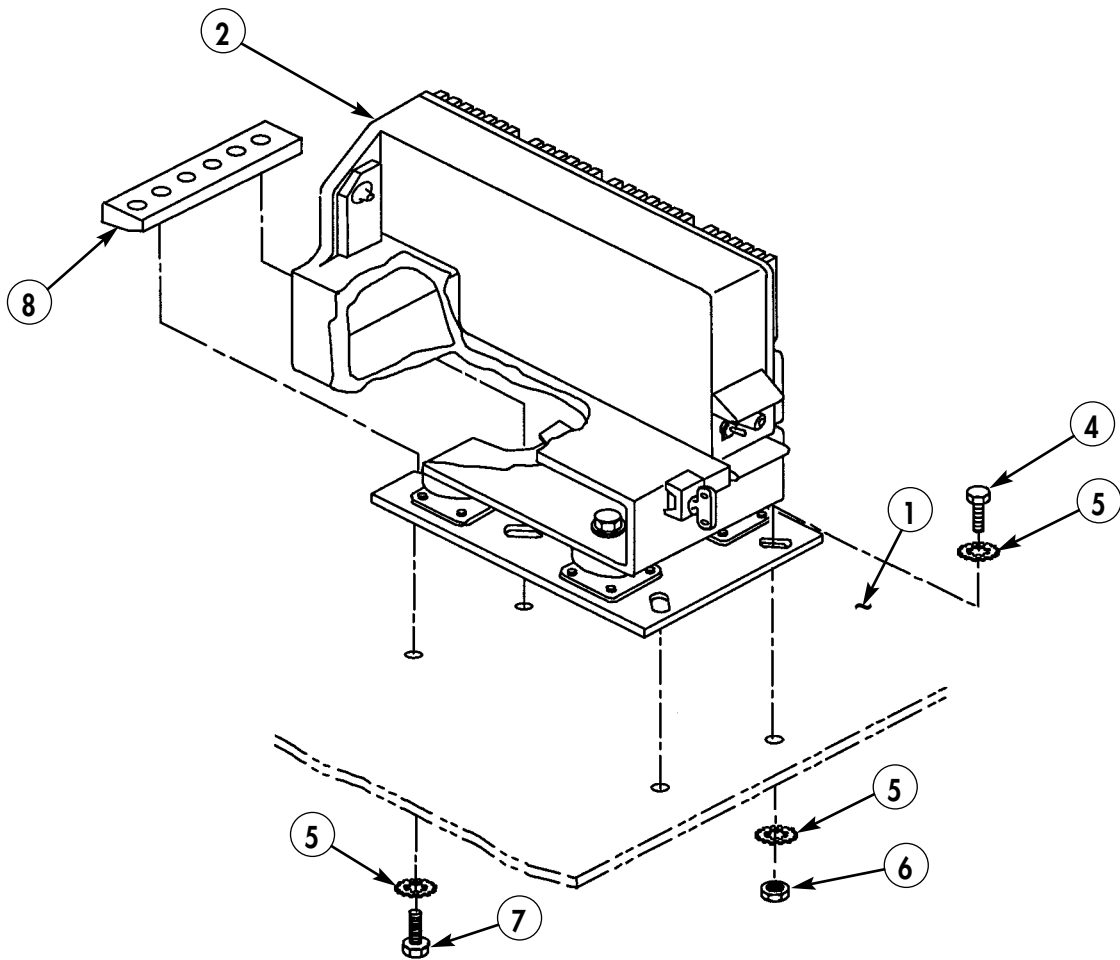

Figure 5-35.

15-3. Install power amp mounting base MT6353/VRC (2) on multi-net rack (1) with nut strip (8), four bolts (4) and (7), six lockwashers (5), and two nuts (6).



- 4. CAPSCREW – B1821BH031F075N – QTY. 2
- 5. LOCKWASHER – MS45904-72 – QTY. 6
- 6. NUT – 9418892 – QTY. 2
- 7. CAPSCREW – B1821BH031F125N – QTY. 2
- 8. NUT STRIP – A3014064-1 – QTY. 1

Figure 5-36.

- 15-4. Route power cable (8) from mounting base MT6353/VRC (2) around multi-net rack (1).
- 15-5. Route control cable (9) from mounting base MT6353/VRC (2) around multi-net rack (1).

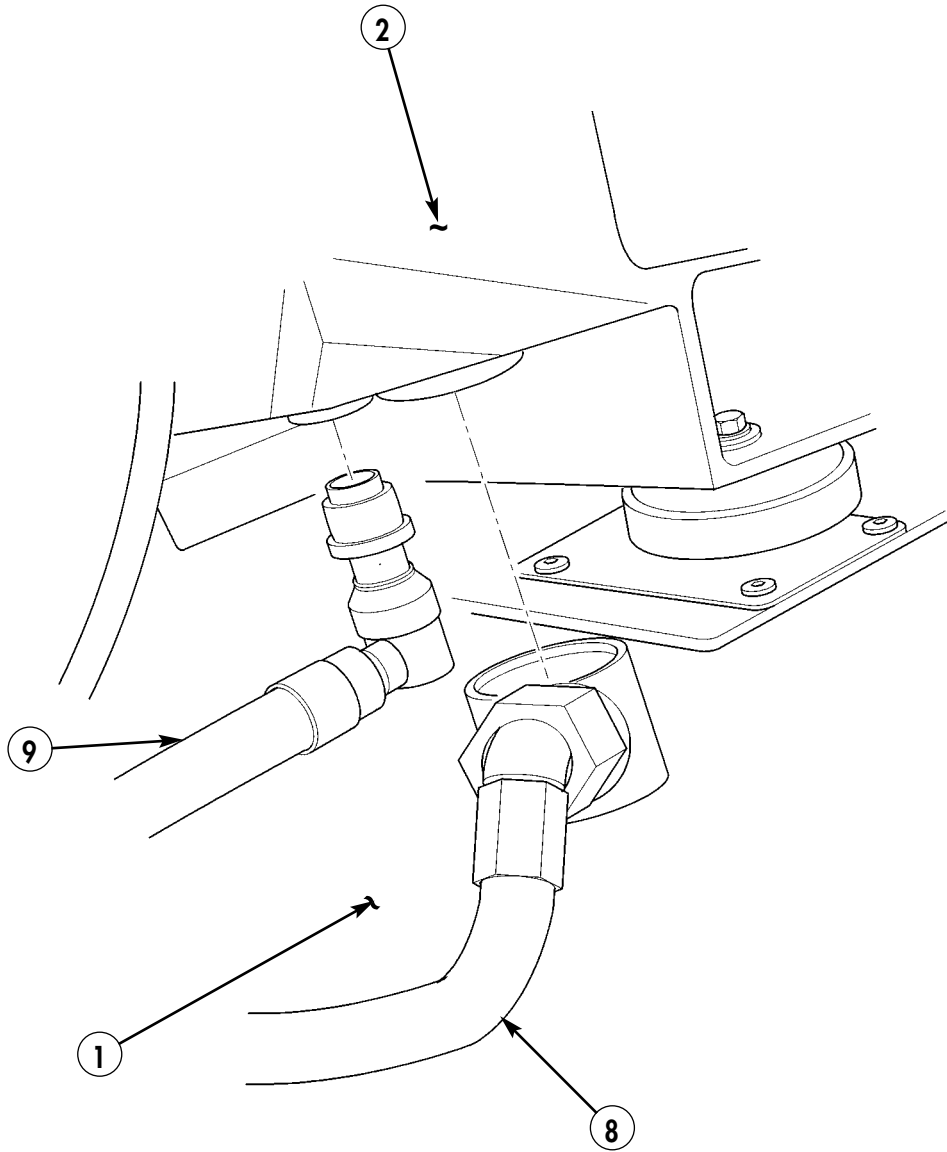

Figure 5-37.

15-6. Connect control cable (9) and power cable (8) to SINCGARS mounting base MT-6352/VRC (10).

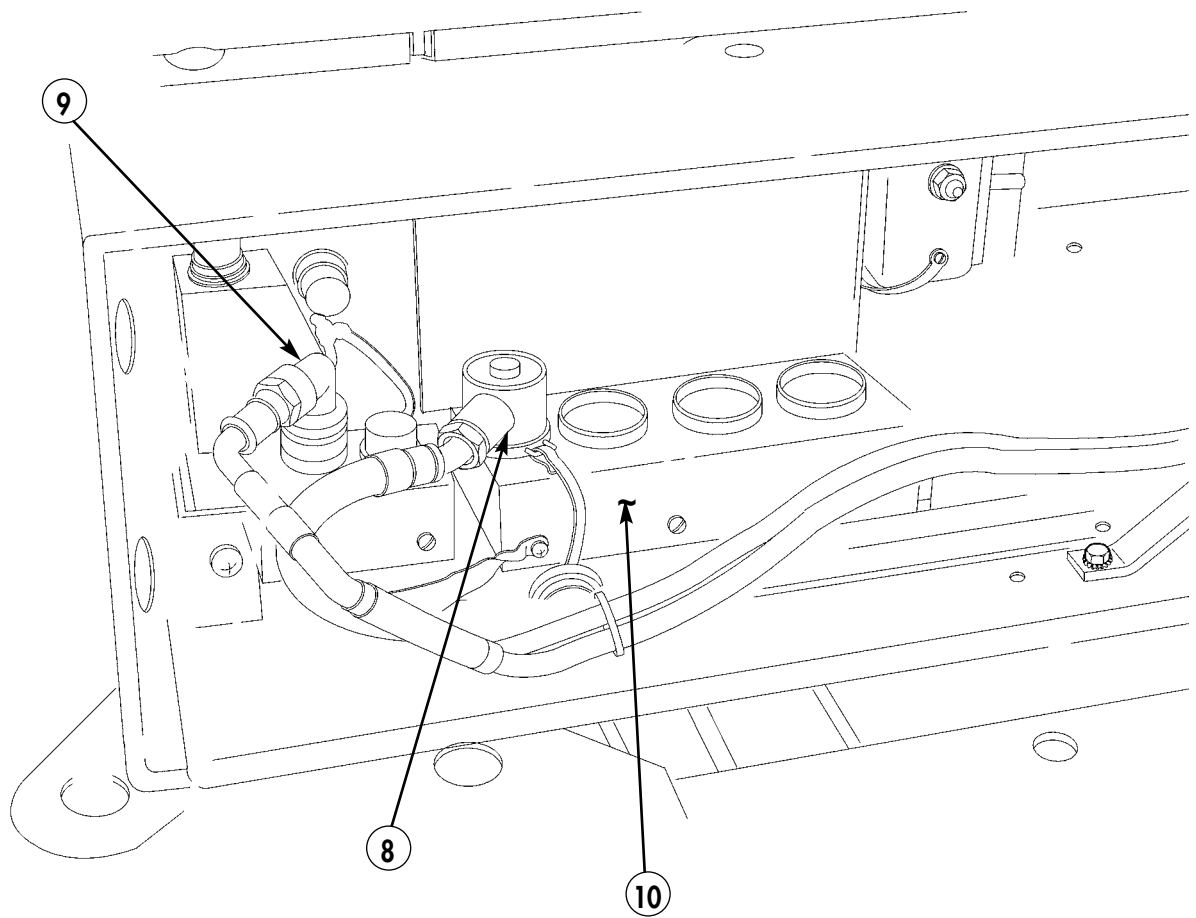

Figure 5-38.

Section XVI. NTDR MOUNTING

- 16-1.** Locate, mark, and drill one 0.343-in. diameter hole (3) in upper right shelf of multi-net rack (2).
- 16-2.** Using mounting tray as template, locate, mark, and drill three remaining 0.343-in. diameter holes (1) in upper right shelf of multi-net rack (2).
- 16-3.** Remove paint from mounting holes (1) and apply anti-seize compound as required.

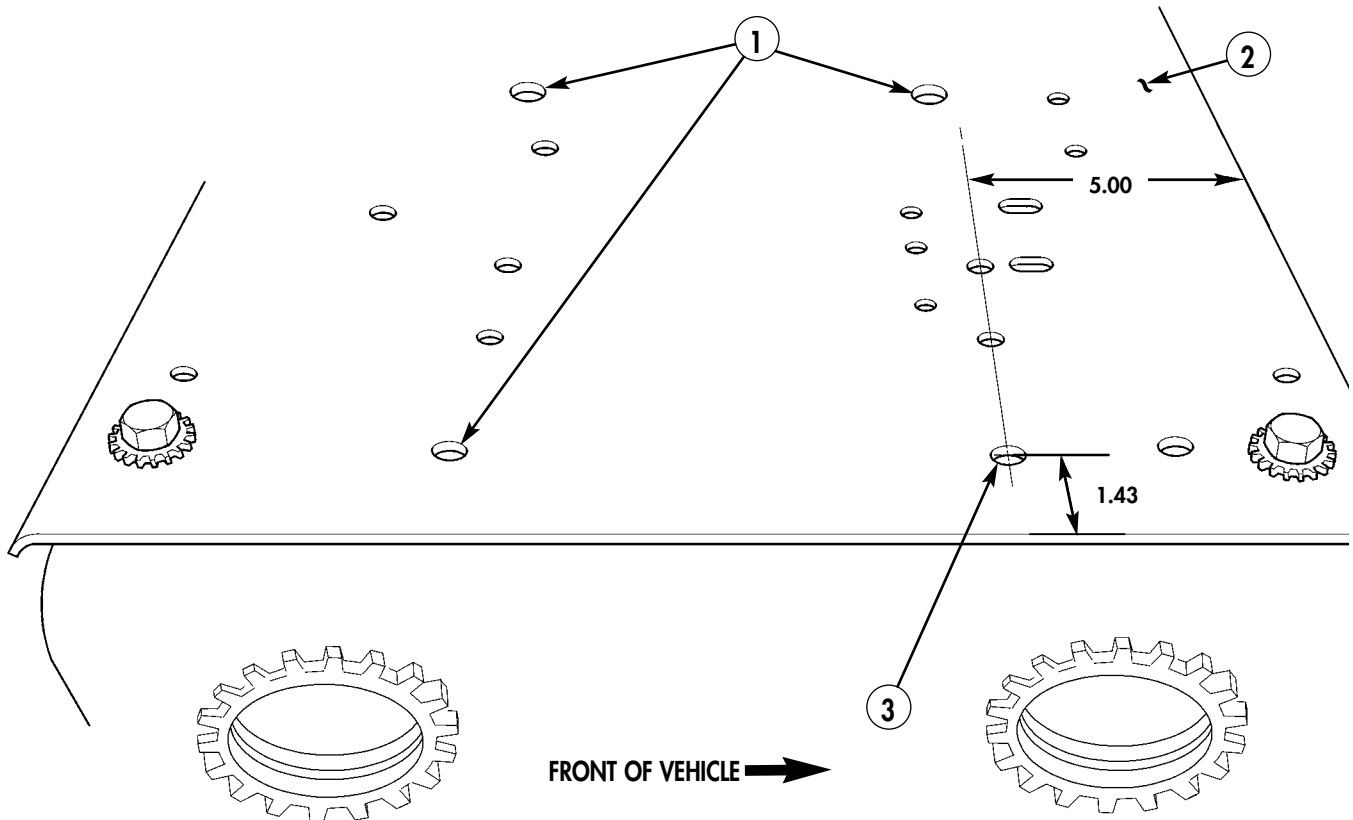
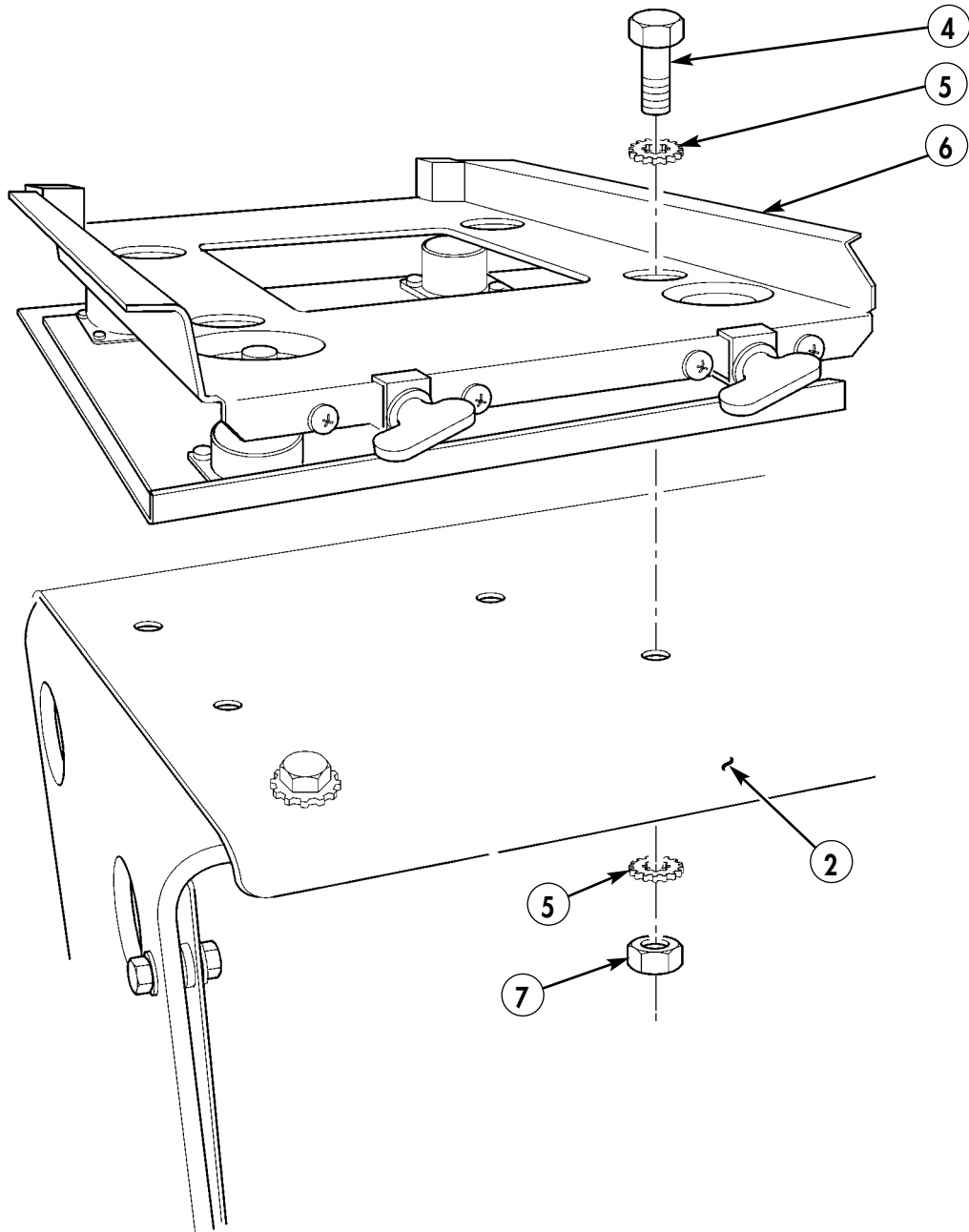

Figure 5-39.

16-4. Install mounting tray (6) on upper right shelf of multi-net rack (2) with four screws (4), eight lockwashers (5), and four nuts (7).



- 4. CAPSCREW – B1821BH031F125N – QTY. 4**
- 5. LOCKWASHER – MS45904-72 – QTY. 8**
- 6. TRAY, MOUNTING – 8174934G1 – QTY. 1**
- 7. NUT – MS51968-5 – QTY. 4**

Figure 5-40.

SECTION XVII. EPLRS MOUNT INSTALLATION

- 17-1.** Using MT-6146/VSQ-1 mount (2) as template, locate, mark, and drill one 0.343-in. diameter hole (5). Remove paint from vicinity of four mounting holes (5) and (7). Apply anti-seize compound as required.
- 17-2.** Install MT-6146/VSQ-1 mount (2) on multi-net rack (1) with four capscrews (3), eight lockwashers (4), and four nuts (6).

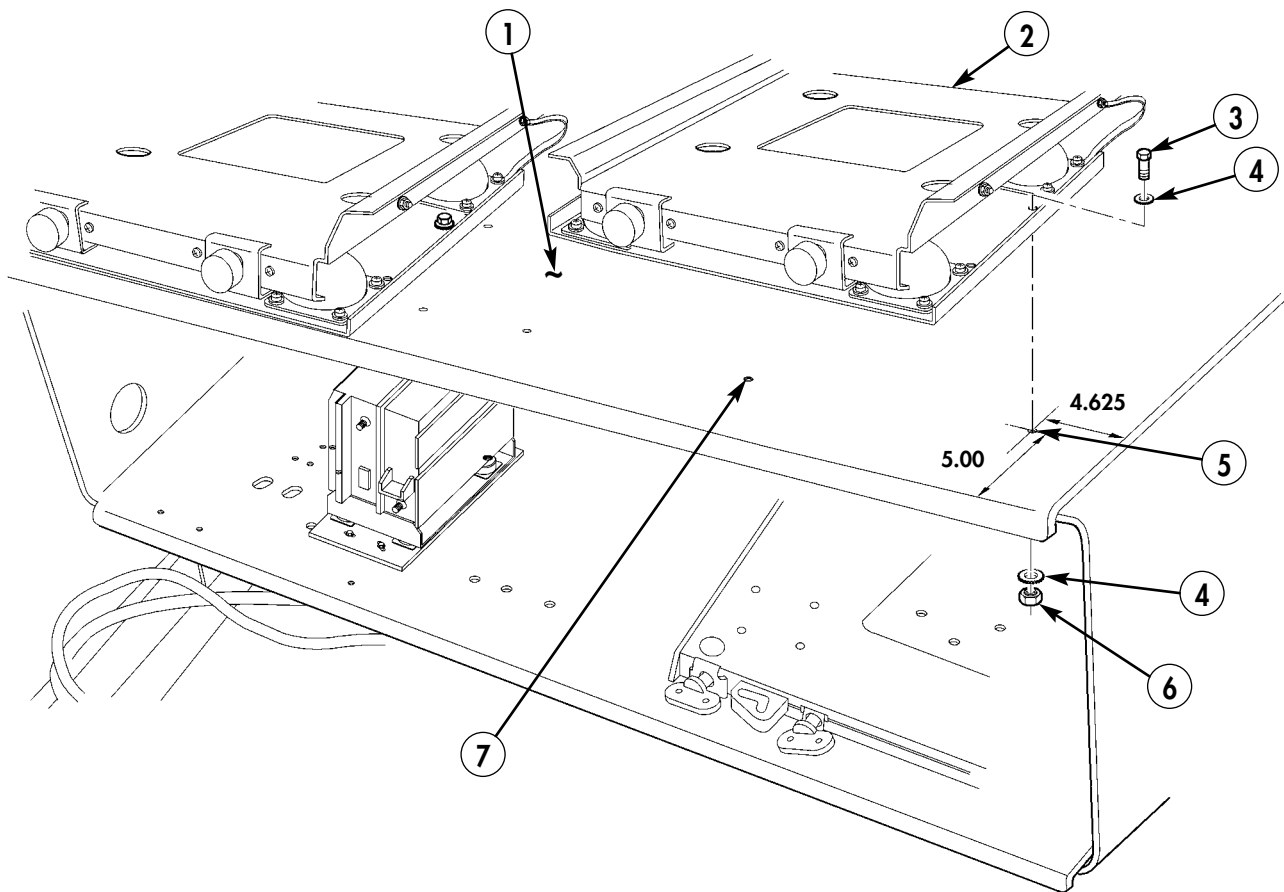

- 2. RESILIENT MOUNT – MT-6146/VSQ – QTY. 1**
3. CAPSCREW – B1821BH031C125N – QTY. 4
4. LOCKWASHER – MS45904-72 – QTY. 8
6. NUT – 9418892 – QTY. 4

Figure 5-41.

Section XVIII. USER READOUT (URO) BRACKET INSTALLATION

- 18-1. Remove two screws (2) and connector mounting bracket (3) from User Readout (URO) bracket (1) and discard.

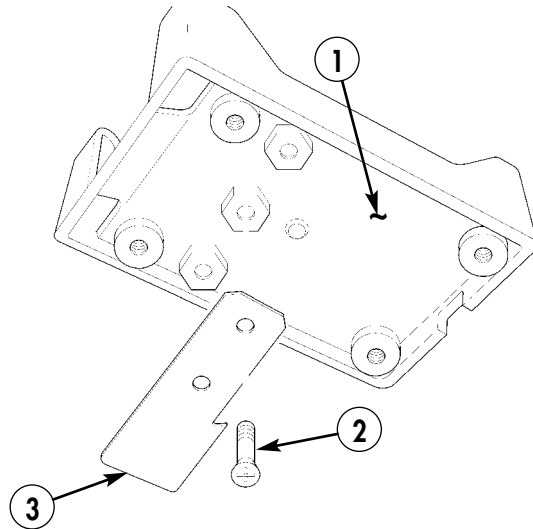
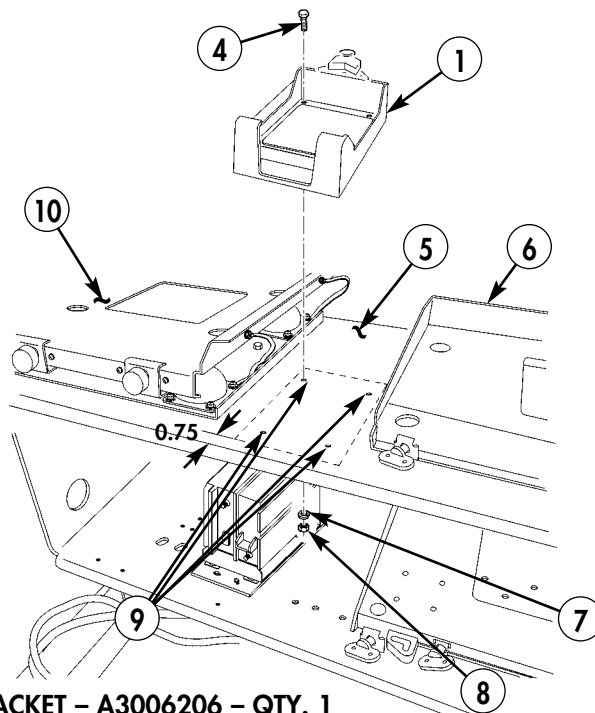

Figure 5-42.

- 18-2. Center URO bracket (1) on multi-net rack (5) between MT-6146/VSQ-1 mount (10) and MT-6352 mount (6).
- 18-3. Using URO bracket (1) as template, locate, mark, and drill four 0.218-in. diameter mounting screw holes (9) in multi-net rack (5).
- 18-4. Install URO bracket (1) on multi-net rack (5) with four screws (4), lockwashers (7), and nuts (8).



1. URO (USER READOUT) BRACKET – A3006206 – QTY. 1
 4. SCREW – MS35207-265 – QTY. 4
 7. LOCKWASHER – MS35338-43 – QTY. 4
 8. NUT – MS35650-302 – QTY. 4

Figure 5-43.

Section XIX. CHARGER INSTALLATION

19-1. Locate, mark, and drill four 0.266-in. diameter holes (2) in multi-net rack (1).

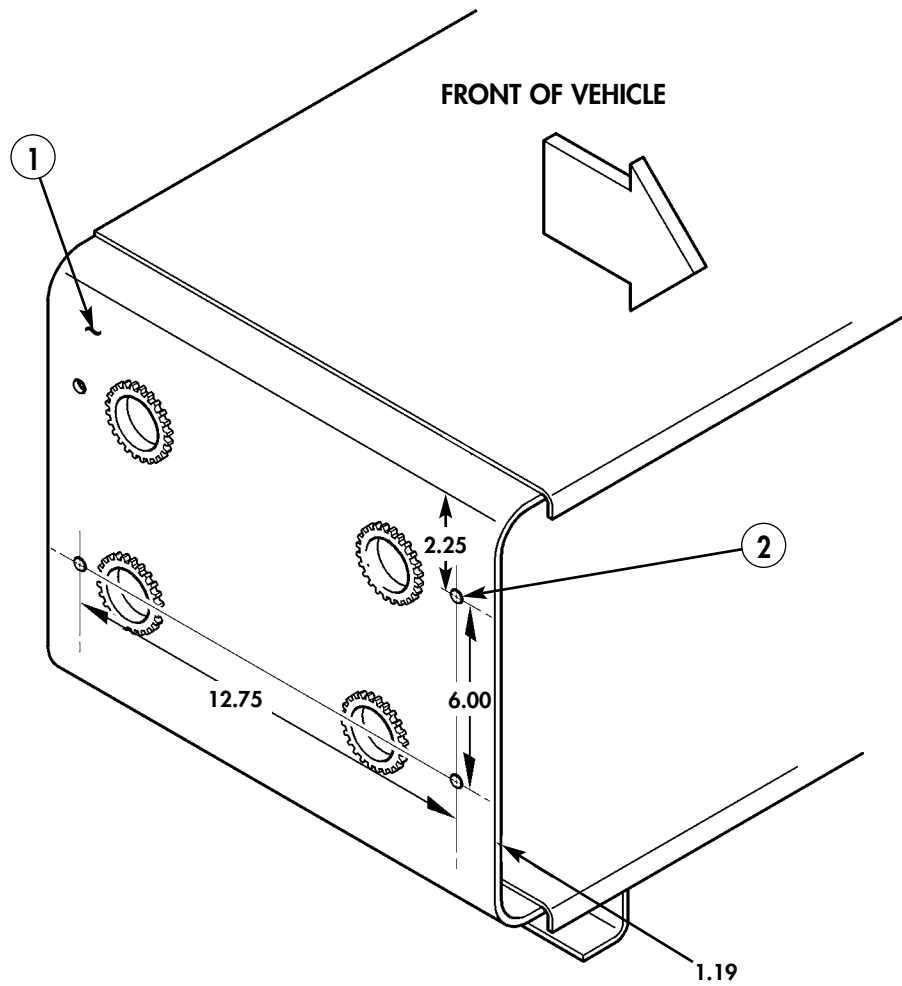
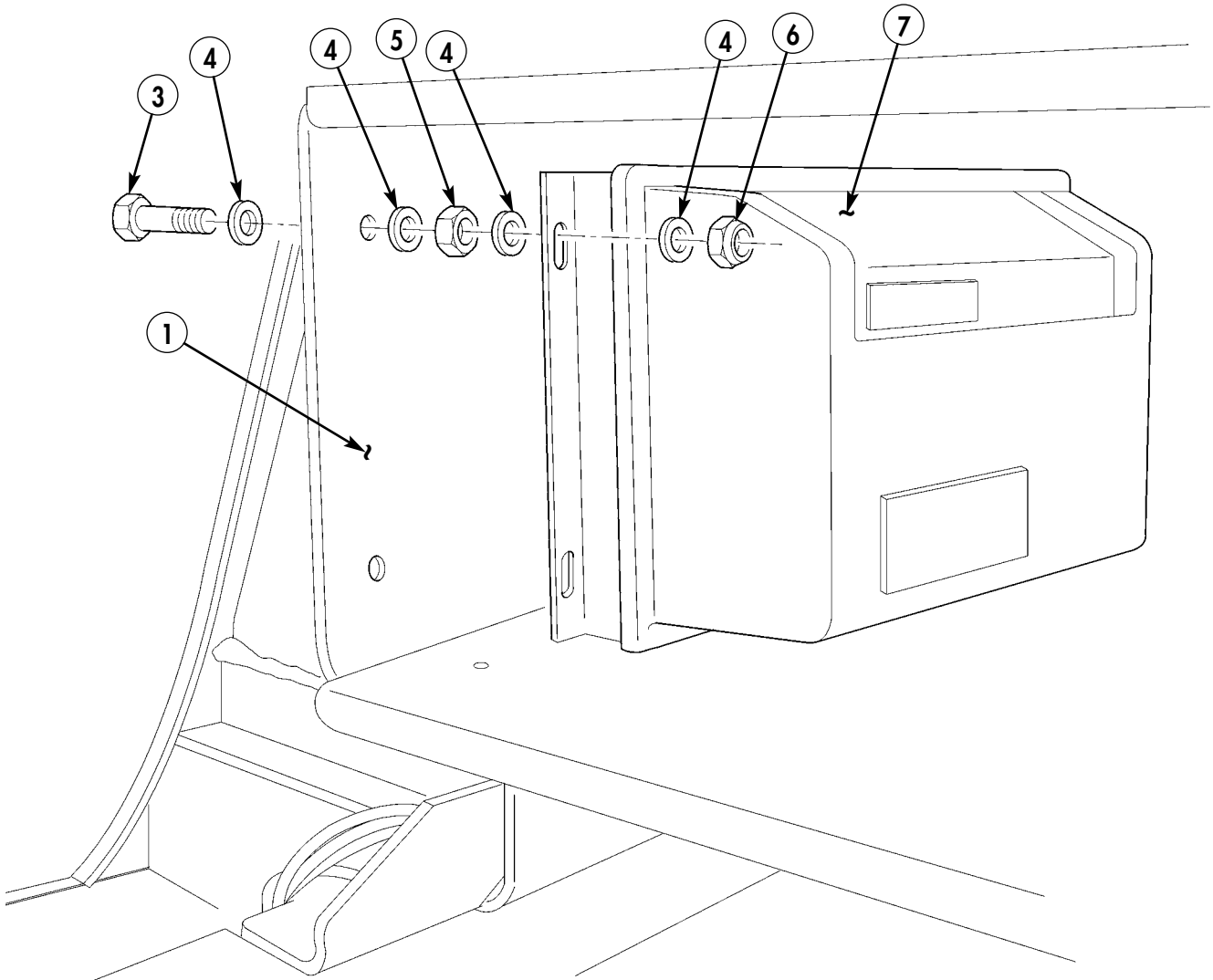

Figure 5-44.

- 19-2. Install charger (7) on multi-net rack (1) with four screws (3), sixteen washers (4), four nuts (5), and four locknuts (6).



- 3. SCREW - B1821BH025C150N - QTY. 4
- 4. WASHER - MS27183-10 - QTY. 16
- 5. NUT - MS51967-2 - QTY. 4
- 6. LOCKNUT - MS17829-4C - QTY. 4

Figure 5-45.

Section XX. EPLRS ANTENNA AND NTDR ANTENNA INSTALLATION

- 20-1. Install grommet (10) on antenna bracket (9).
- 20-2. Position antenna (2), gasket (16), NTDR antenna bracket (6), and gasket (16) on antenna mounting bracket (9).
- 20-3. Install antenna (2) on antenna mounting bracket (9) with four capscrews (1), eight lockwashers (12), and four nuts (15).
- 20-4. Install antenna mounting bracket (9) on fiberglass body (11) with three capscrews (14), washers (12), and three nuts (13).
- 20-5. Install NTDR antenna (3), adapter (4), and gasket (5) to NTDR antenna bracket (6). Secure with washer (7) and nut (8).

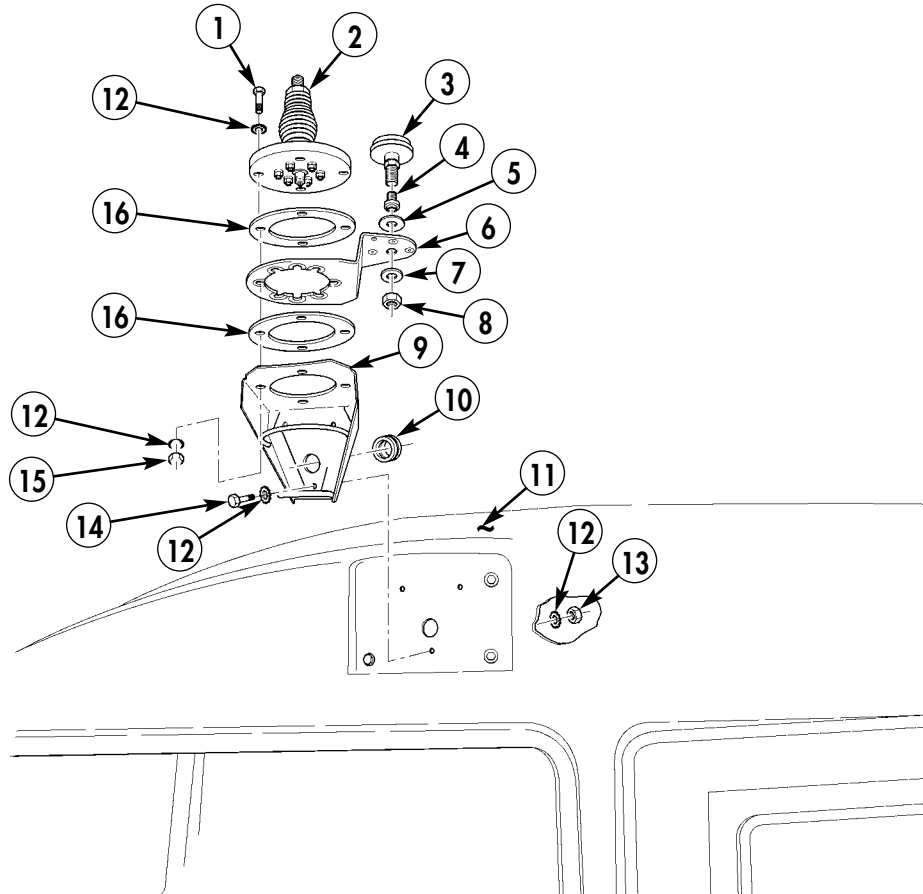

- 1. CAPSCREW - MS35307-365 - QTY. 4
- 2. ANTENNA - A3005031 - QTY. 1
- 3. NTDR ANTENNA - 8173964-1 - QTY. 1
- 4. ADAPTER - N/A - QTY. 1
- 5. GROMMET - N/A - QTY. 1
- 6. BRACKET - N/A - QTY. 1
- 7. WASHER - N/A - QTY. 1
- 8. NUT - N/A - QTY. 1
- 9. ANTENNA MOUNTING BRACKET - A3014546-1 - QTY. 1
- 10. GROMMET - 12338098 - QTY. 1
- 12. LOCKWASHER - MS45904-72 - QTY. 11
- 13. NUT - 9418892 - QTY. 3
- 14. CAPSCREW - B1821BH031F125N - QTY. 3
- 15. NUT - 13218E0320-293 - QTY. 4
- 16. GASKET - A3013655-1 - QTY. 2

Figure 5-46.

SECTION XXI. LEFT-SIDE SINGARS ANTENNA MOUNT INSTALLATION

21-1. Install angled plate (1) on antenna support (2) with four screws (6), eight washers (5), four lockwashers (4), and four nuts (3).

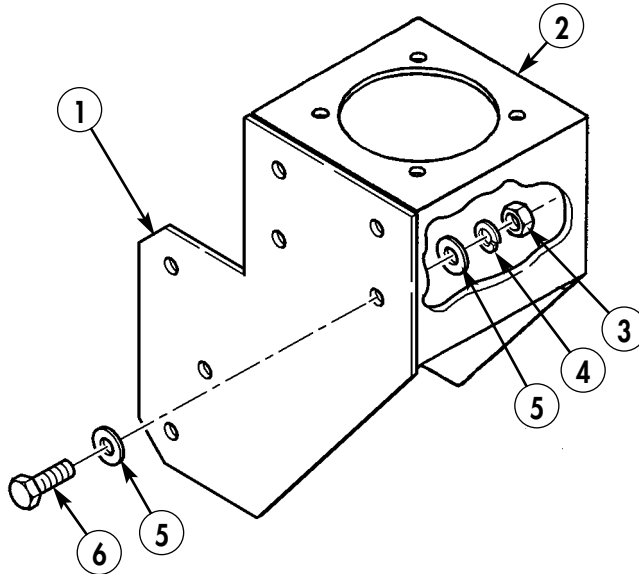

- 1. PLATE (ANGLED) – A3103740 – QTY. 1
- 2. ANTENNA SUPPORT – A3103782 – QTY. 1
- 3. NUT – MS35690-610 – QTY. 4
- 4. LOCKWASHER – MS35338-141 – QTY. 4
- 5. WASHER – MS15795-814 – QTY 8
- 6. SCREW – MS90725-64 – QTY. 4

Figure 5-47.

21-2. Using angled plate (1) as template, locate, mark, and drill three 0.406-in. diameter holes on left-side rear wheelhouse (7).

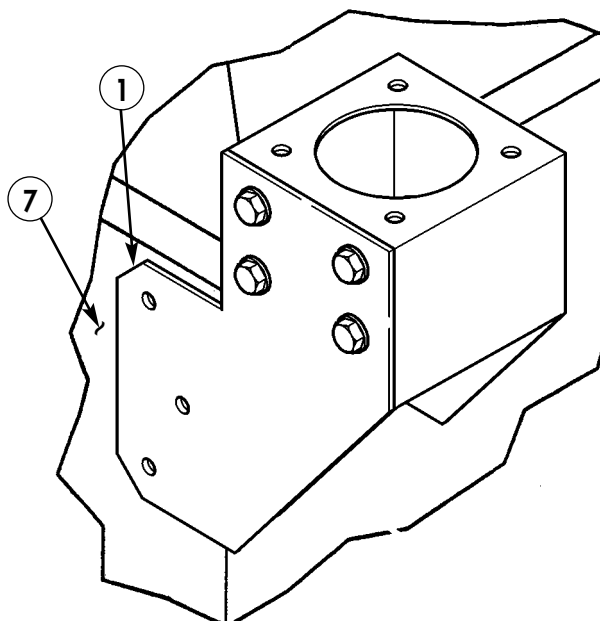
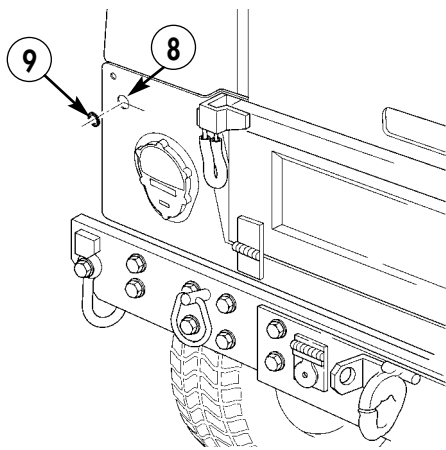

Figure 5-48.

21-3. Install 4.250-in. piece of plastic edge grommet (9) in hole (8) of left-side wheelhouse (7).

21-4. Secure antenna support (2) and angled plate (1) to left-side wheelhouse (7) with screws (6) and nuts (3).



9. GROMMET – MS21266-4N – QTY. A/R

Figure 5-49.

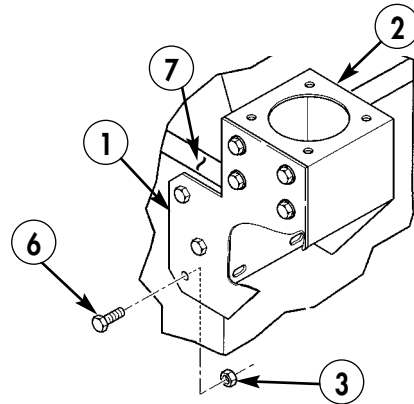

3. NUT – MS35690-610 – QTY. 3
6. SCREW – MS90725-64 – QTY. 3

Figure 5-50.

21-5. Install 4.250-in. piece of plastic edge grommet (9) in hole (10) of antenna support (2).

21-6. Secure angled plate (1) and antenna support (2) to left-side wheelhouse (7) with backing plate (12), three screws (6), six washers (5), three lockwashers (4), and three nuts (3).

21-7. Secure antenna support (2) to left-side wheelhouse (7) with plate (11), two screws (6), four washers (5), two lockwashers (4), and two nuts (3).

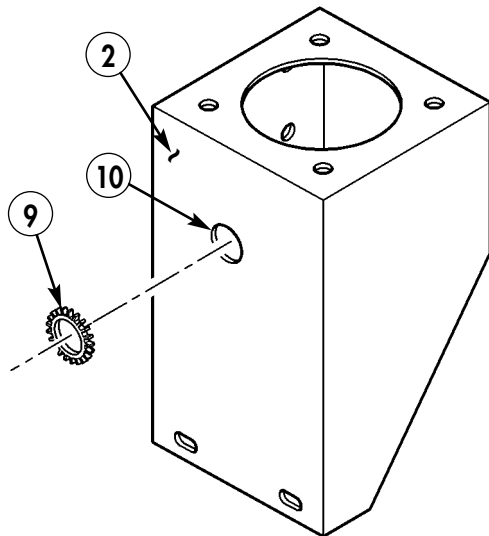

9. GROMMET – MS21266-4N – QTY. A/R

Figure 5-51.

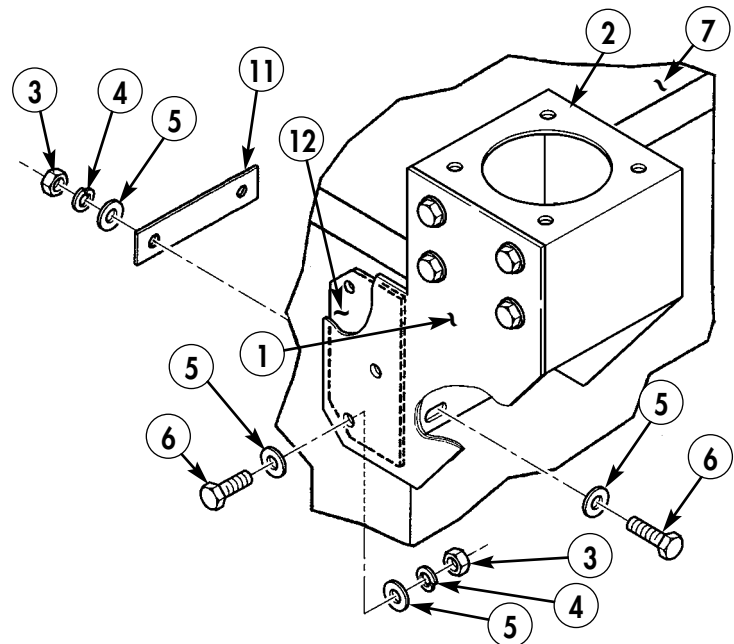

3. NUT – MS35690-610 – QTY. 5
4. LOCKWASHER – MS35338-141 – QTY. 5
5. WASHER – MS15795-814 – QTY. 10
6. SCREW – MS90725-64 – QTY. 5
11. PLATE – A3103784 – QTY. 1
12. BACKING PLATE – A3046222 – QTY. 1

Figure 5-52.

- 21-8. Install upper half of antenna mount (14) on lower half of antenna mount (17) with four screws (15), eight washers (5), four lockwashers (4), and nuts (3).

NOTE

Ensure holes of antenna base and grommets align with weldnut holes in mounting bracket.

- 21-9. Install antenna (22) and gasket (21) on upper half of antenna mount (14) and secure with four screws (13), lockwashers (24), and washers (23).

NOTE

Prior to securing antenna ground lead, enlarge hole on offset mount with 9/32-in. drill bit to allow 1/4-in. screw to fit.

- 21-10. Secure antenna ground lead (19) to upper half of antenna mount (14) with screw (16), lockwasher (18), and nut (20).

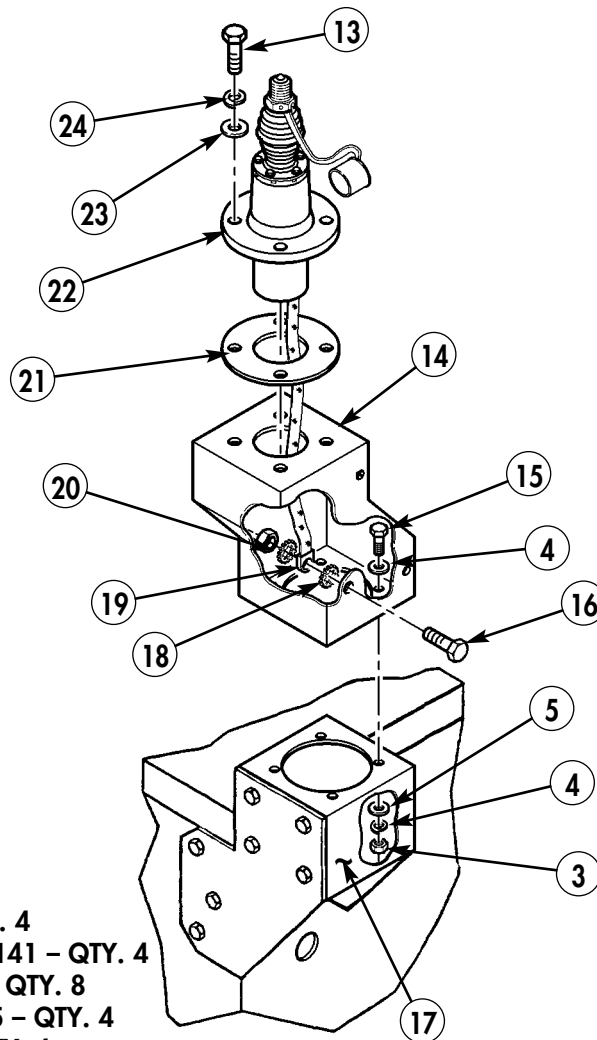

- 3. NUT - MS35690-610 - QTY. 4
- 4. LOCKWASHER - MS35338-141 - QTY. 4
- 5. WASHER - MS15795-814 - QTY. 8
- 13. CAPSCREW - MS35307-365 - QTY. 4
- 15. SCREW - MS90725-62 - QTY. 4
- 16. SCREW - MS35027-263 - QTY. 1
- 18. LOCKWASHER - MS45904-68 - QTY. 2
- 20. NUT - MS35650-302 - QTY. 1
- 21. GASKET - A3013655-1 - QTY. 1
- 22. ANTENNA - A3017899-2 - QTY. 1
- 23. WASHER - 2436163 - QTY. 8
- 24. LOCKWASHER - MS45904-72 - QTY. 4

Figure 5-53.

- 21-11. Attach upper antenna element (25) to lower antenna element (27).
- 21-12. Attach antenna assembly to antenna base (22).
- 21-13. Attach fiber rope assembly (26) to upper antenna element (25).
- 21-14. Secure lower antenna element (27) to antenna base (22) with lock wire (28).

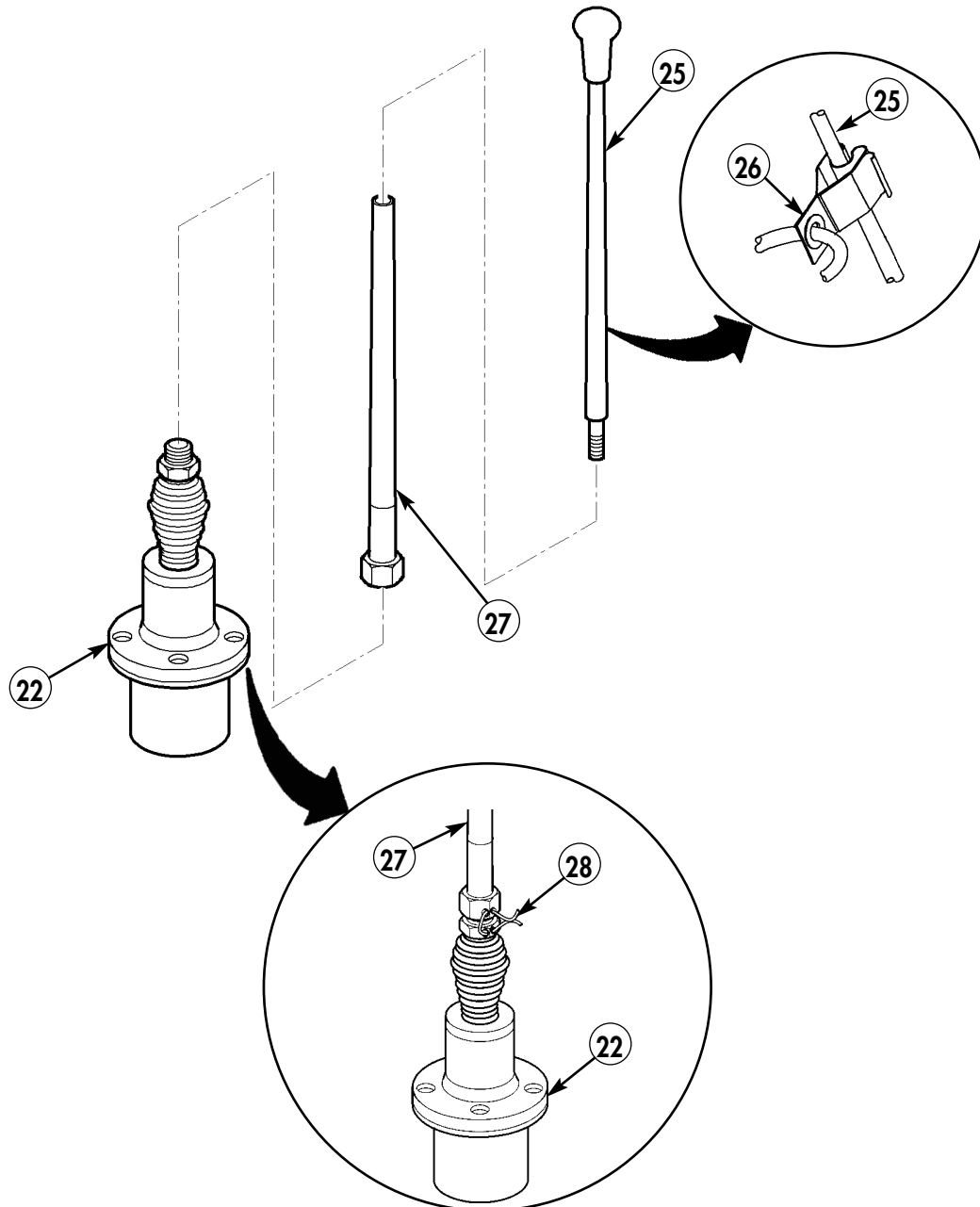

- 25. UPPER ANTENNA ELEMENT – A3017901-2 – QTY. 1
- 27. LOWER ANTENNA ELEMENT – A3018230-1 – QTY. 1
- 28. LOCK WIRE – MS20995C32 – QTY. A/R

Figure 5-54.

SECTION XXII. RIGHT-SIDE SINGARS ANTENNA MOUNT INSTALLATION

22-1. Install angled plate (2) on antenna support (1) with four screws (4), eight washers (3), four lockwashers (5), and four nuts (6).

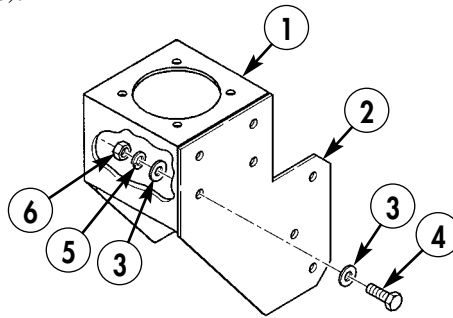

1. ANTENNA SUPPORT – A3103782 – QTY 1
2. PLATE (ANGLED) – A3103740 – QTY 1
3. WASHER – MS15795-814 – QTY 8
4. SCREW – MS90725-64 – QTY. 4
5. LOCKWASHER – MS35338-141 – QTY. 4
6. NUT – MS35690-610 – QTY. 4

Figure 5-55.

22-2. Using angled plate (2) as template, locate, mark, and drill three 0.406-in. diameter holes on right-side rear wheelhouse (7).

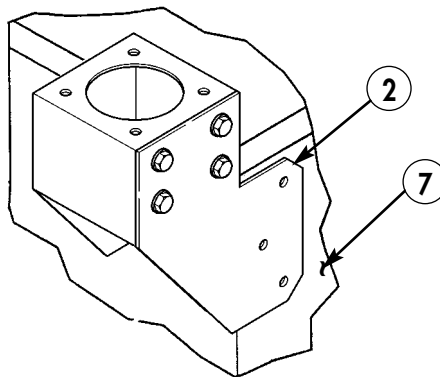
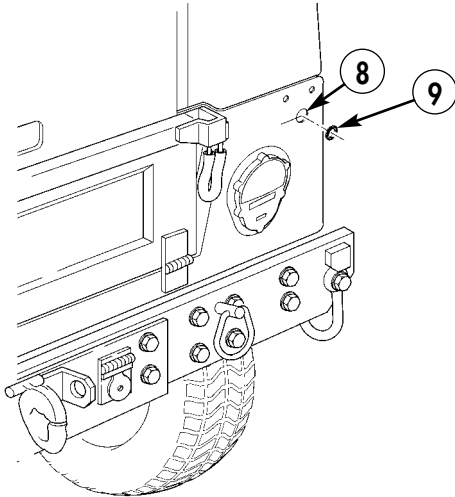

Figure 5-56.

- 22-3. Install 4.250-in. piece of plastic edge grommet (9) in hole (8) of right wheelhouse (10).
- 22-4. Secure antenna support (1) and angled plate (2) to right-side wheelhouse (10) with screws (4) and nuts (6).
- 22-5. Using antenna support (1) as template, locate, mark, and drill two 0.406-in. diameter holes (8) on right-side wheelhouse (10).



9. GROMMET – MS21266-4N – QTY. A/R

Figure 5-57.

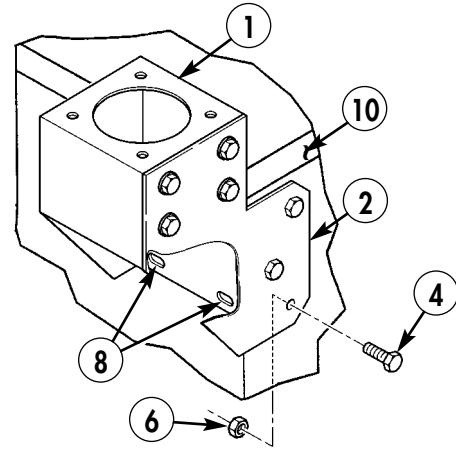

4. SCREW – MS90725-64 – QTY. 3

6. NUT – MS35690-610 – QTY. 3

Figure 5-58.

- 22-6. Install 4.250-in. piece of plastic edge grommet (9) in hole of antenna bracket (11).
- 22-7. Secure angled plate (2) and antenna support (1) to right-side wheelhouse (10) with backing plate (13), three screws (4), six washers (3), three lockwashers (5), and three nuts (6).
- 22-8. Secure antenna support (1) to right-side wheelhouse (10) with plate (12), two screws (4), four washers (3), two lockwashers (5), and two nuts (6).

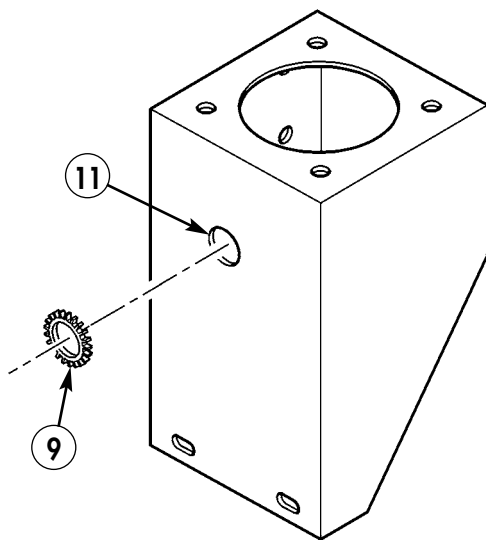

9. GROMMET – MS21266-4N – QTY. A/R

Figure 5-59.

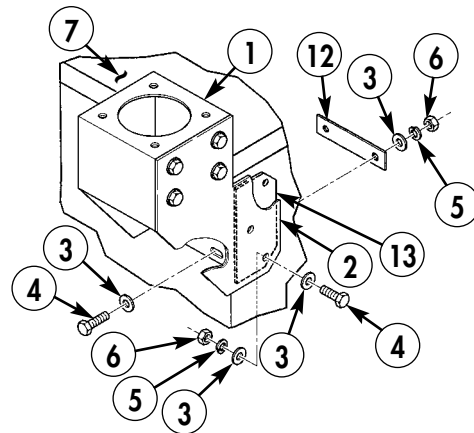

3. WASHER – MS15795-814 – QTY. 10

4. SCREW – MS90725-64 – QTY. 5

5. LOCKWASHER – MS35338-141 – QTY. 5

6. NUT – MS35690-610 – QTY. 5

12. PLATE – A3103784 – QTY. 1

13. BACKING PLATE – A3046222 – QTY. 1

Figure 5-60.

22-9. Install upper half of antenna mount (18) to lower half of antenna mount (22) with four screws (24), eight washers (3), four lockwashers (5), and nuts (6).

NOTE

Ensure holes of antenna base align with weldnut holes in mounting bracket.

22-10. Install antenna (25) and gasket (17) on upper half of antenna mount (18) and secure with screws (14), lockwashers (15), and washers (16).

NOTE

Prior to securing antenna ground lead, enlarge hole on offset mount with 9/32-in. drill bit to allow 1/4-in. screw to fit.

22-11. Secure antenna ground lead (20) to upper half of antenna mount (18) with screw (23), lockwasher (21), and nut (19).

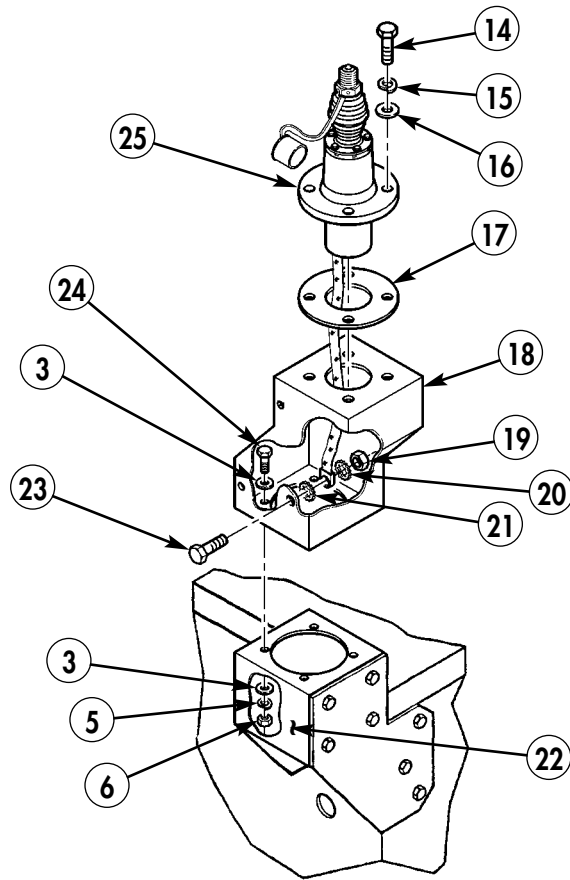

- | | |
|--------------------------------------|--------------------------------------|
| 3. WASHER – MS15795-814 – QTY. 8 | 17. GASKET – A3013655-1 – QTY. 1 |
| 5. LOCKWASHER – MS35338-141 – QTY. 4 | 19. NUT – MS35650-302 – QTY. 1 |
| 6. NUT – MS35690-610 – QTY. 4 | 21. LOCKWASHER – MS45904-68 – QTY. 2 |
| 14. CAPSCREW – MS35307-365 – QTY. 4 | 23. SCREW – MS35027-263 – QTY. 1 |
| 15. LOCKWASHER – MS45904-72 – QTY. 4 | 24. SCREW – MS90725-62 – QTY. 4 |
| 16. WASHER – 2436163 – QTY. 8 | 25. ANTENNA – A3017899-2 – QTY. 1 |

Figure 5-61.

- 22-12. Attach upper antenna element (26) to lower antenna element (28).
- 22-13. Attach antenna assembly to antenna base (23).
- 22-14. Attach fiber rope assembly (27) to upper antenna element (26).
- 22-15. Secure lower antenna element (28) to antenna base (23) with lock wire (29).

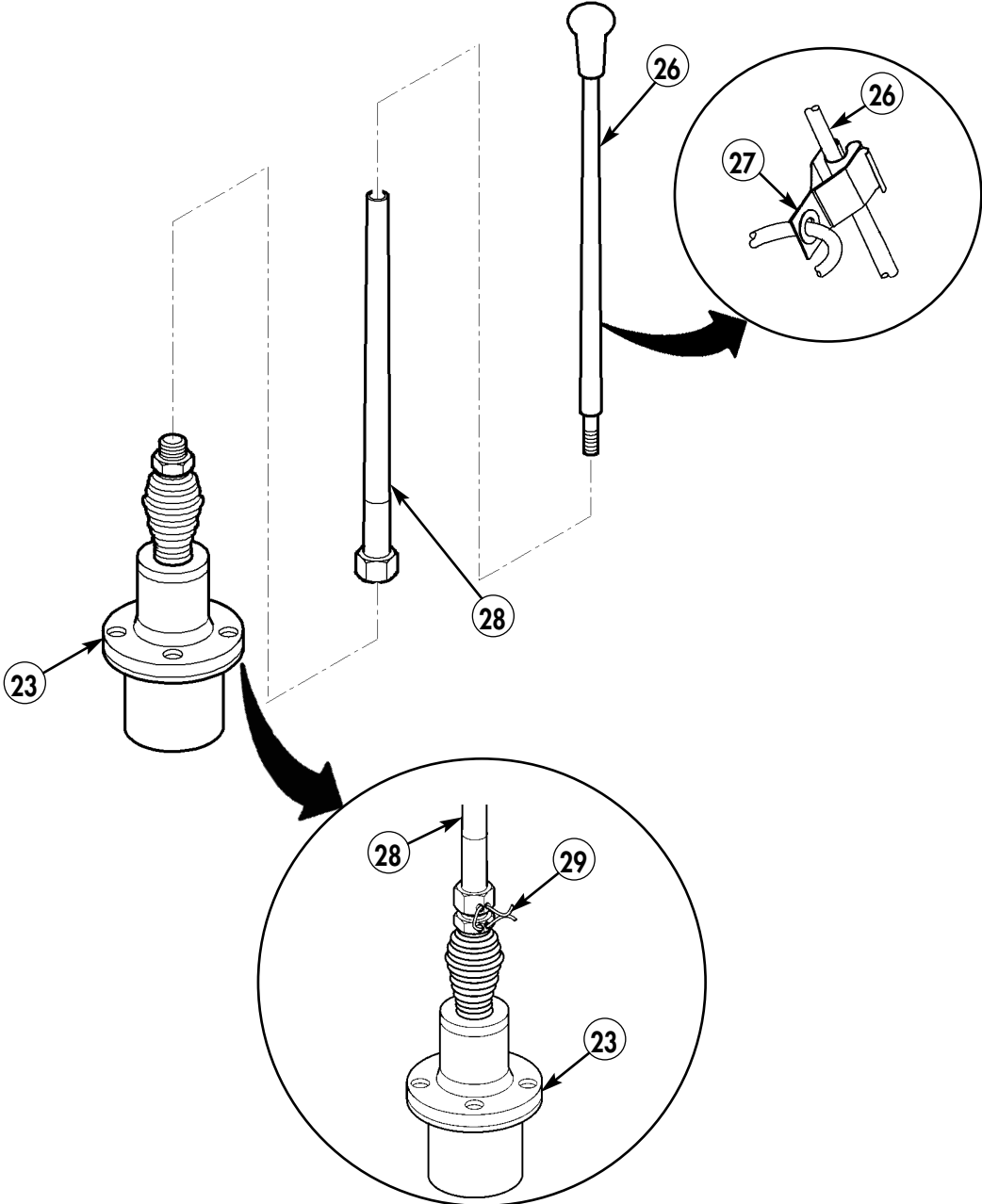

- 26. UPPER ANTENNA ELEMENT – A3017901-2 – QTY. 1
- 28. LOWER ANTENNA ELEMENT – A3018230-1 – QTY. 1
- 29. LOCK WIRE – MS20995C32 – QTY. A/R

Figure 5-62.

Section XXIII. QEAM MOUNTING: ANTENNAS AND BRACKETS

23-1. Install four clamp subassemblies (5) on QEAM rack (4) with four screws (1), washers (2), and lockwashers (3).

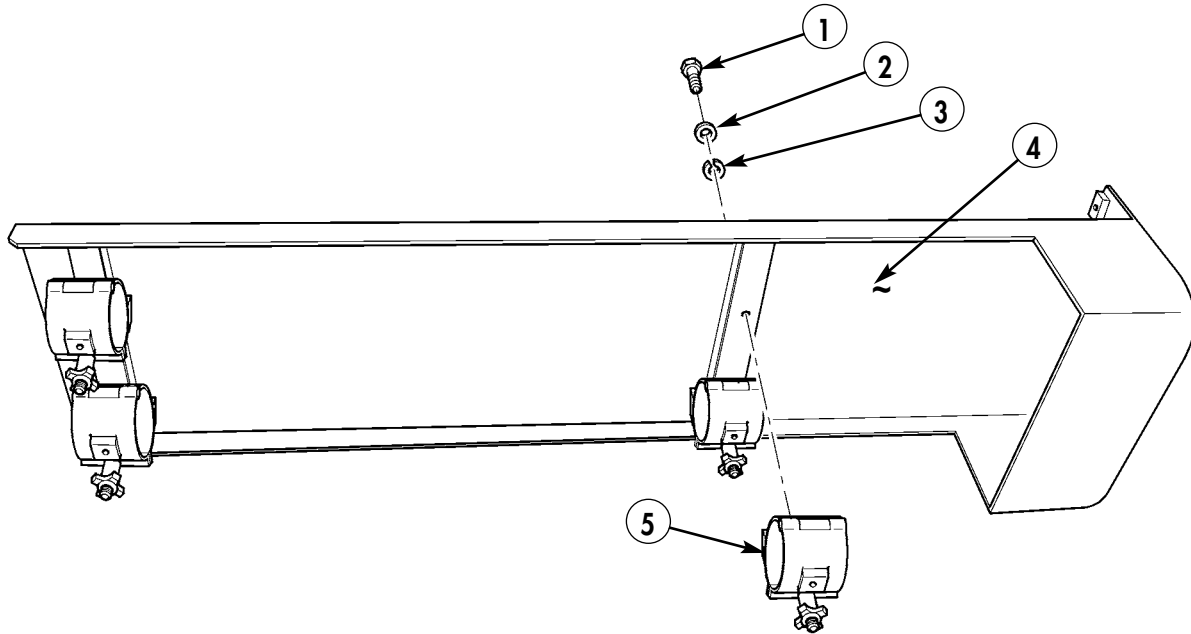

- 1. SCREW – 8599267-531 – QTY. 4
- 2. WASHER – MS27183-14 – QTY. 4
- 3. LOCKWASHER – MS35338-46 – QTY. 4
- 4. RACK, QEAM – PKMM 000-006 – QTY. 1
- 5. CLAMP SUBASSEMBLY – A3209994 – QTY.4

Figure 5-63.

23-2. Using QEAM rack (4) as template, locate, mark, and drill four 0.344-in. diameter holes (9) in roof of vehicle (14).

23-3. Mark location for four QEAM spacers (8) and apply RTV sealant to marked areas (10).

NOTE

Allow RTV to cure for 30 minutes.

23-4. Press four spacers (8) onto roof of vehicle (14).

23-5. Position QEAM rack (4) over holes in four spacers (8).

23-6. Apply RTV to four bolt holes (9) and insert four bolts (6) and washers (7) in QEAM carrier.

23-7. Apply RTV to one side of four washers (11). Press washers (11) in place.

23-8. Install lockwasher (12) and nut (13).

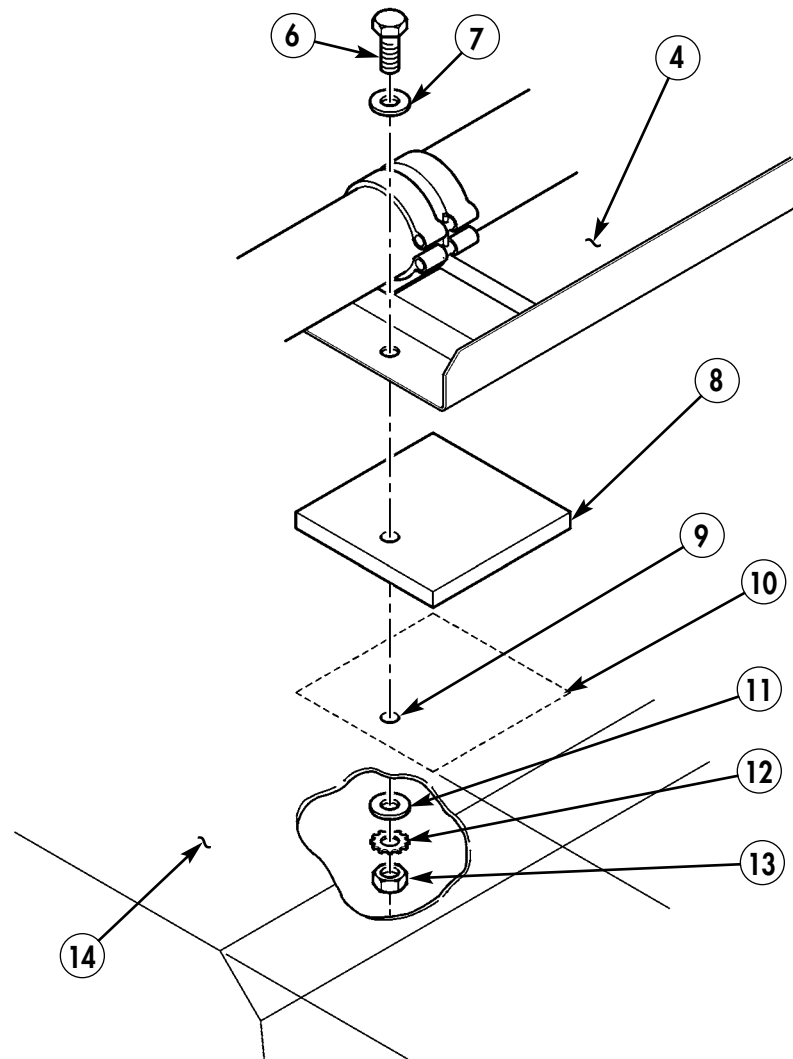

- 6. SCREW - B1821BH031C300N - QTY. 4
- 7. WASHER - 120393 - QTY. 4
- 8. SPACER, QEAM (PART OF PKMM 000-006) - QTY. 4
- 11. WASHER - 120393 - QTY. 4
- 12. LOCKWASHER - MS45904-72 - QTY. 4
- 13. NUT - MS51967-6 - QTY. 4

Figure 5-64.

NOTE

Use folding step as a template to correctly space holes.

- 23-9.** Using folding step (21) as template, locate, mark, and drill two 0.328-in. diameter holes (16) in body of vehicle (15).

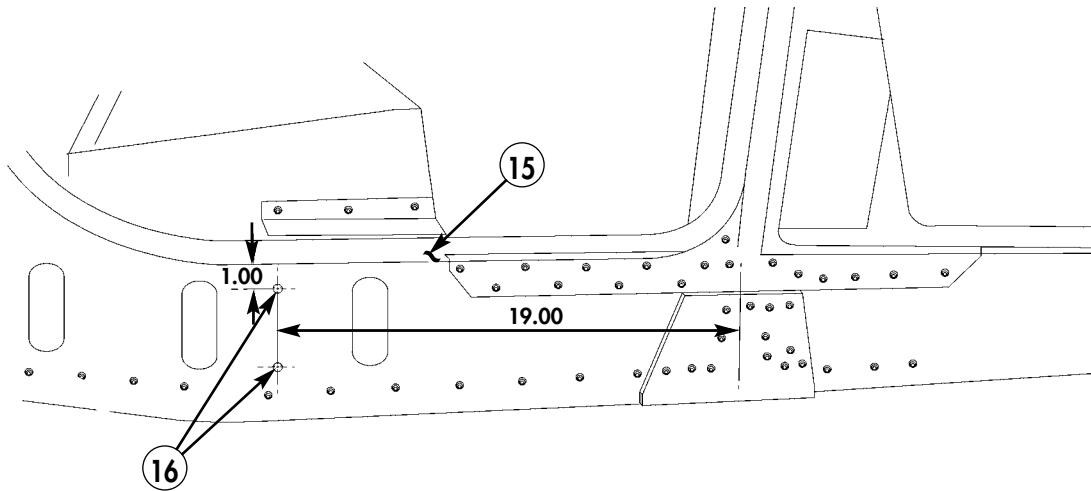

Figure 5-65.

- 23-10.** Using folding step (21) as template, locate, mark, and drill two 0.328-in. diameter holes (17) in body of vehicle (15).

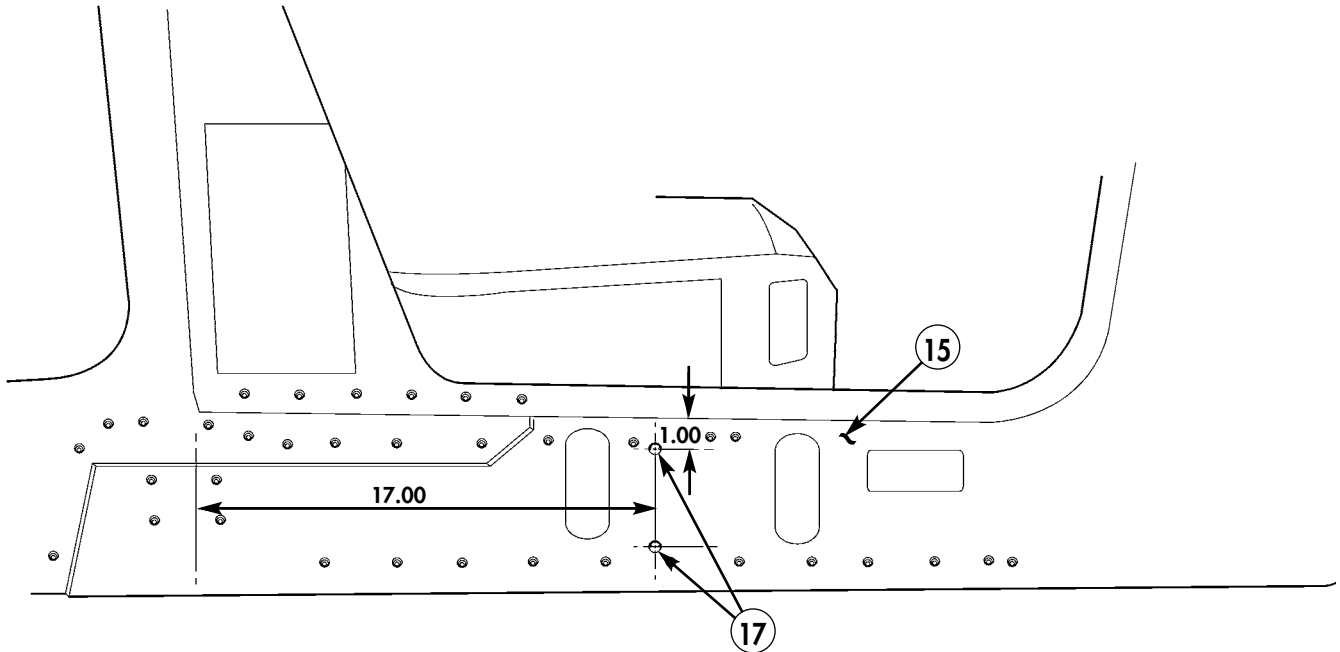
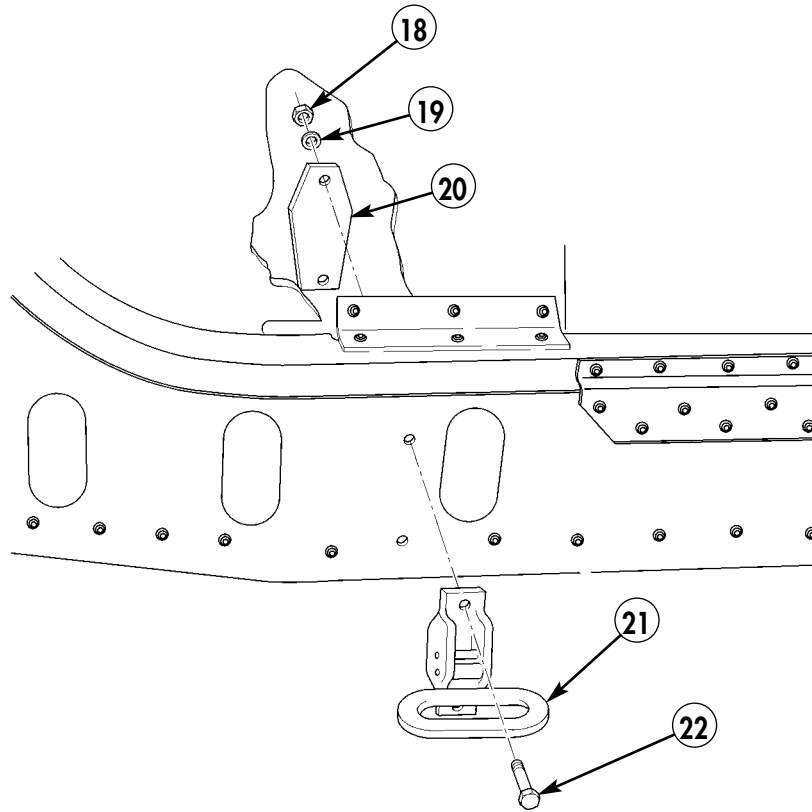

Figure 5-66.

NOTE

Rear folding step installation is shown. Front folding step is mounted the same way.

- 23-11.** Install folding step (21) with two screws (22), backing plate (20), two washers (19), and locknuts (18).



18. LOCKNUT - MS17829-5C - QTY. 2
 19. WASHER - MS51412-25 - QTY. 2
 20. BACKING PLATE - P/O PKMM 000-006 - QTY. 1
 21. FOLDING STEP - P/O PKMM 000-006 - QTY. 1
 22. SCREW - B1821BH031C125N - QTY.1

Figure 5-67.

Section XXIV. SINGARS CABLES INSTALLATION

NOTE

- This procedure applies to vehicles without existing antennas. For vehicles with existing antennas, remove all control cables. (Refer to TM 9-2320-280-20.)
- Previously routed cables have been removed from figure 5-68 for clarity.

- 24-1. Route antenna cable (7) from left side of mounting base (1), down through center access hole (4), under integrated rack (5), and under right-side tunnel insulation (8) towards rear of vehicle.
- 24-2. Route antenna cable (9) from mounting base (1) to MT-6353/VRC mounting base (11).
- 24-3. Route power amp cable (2) from MT-6353/VRC mounting base (11), up through center access hole (4), and connect power amp cable (2) to connector on W1J1 cable (2.1).
- 24-4. Route control cable (3) from MT-6353/VRC mounting base (11), up through center access hole (4), to mounting base (1).
- 24-5. Route antenna cable (6) from front of MT-6353/VRC mounting base (11) and under integrated rack (5).

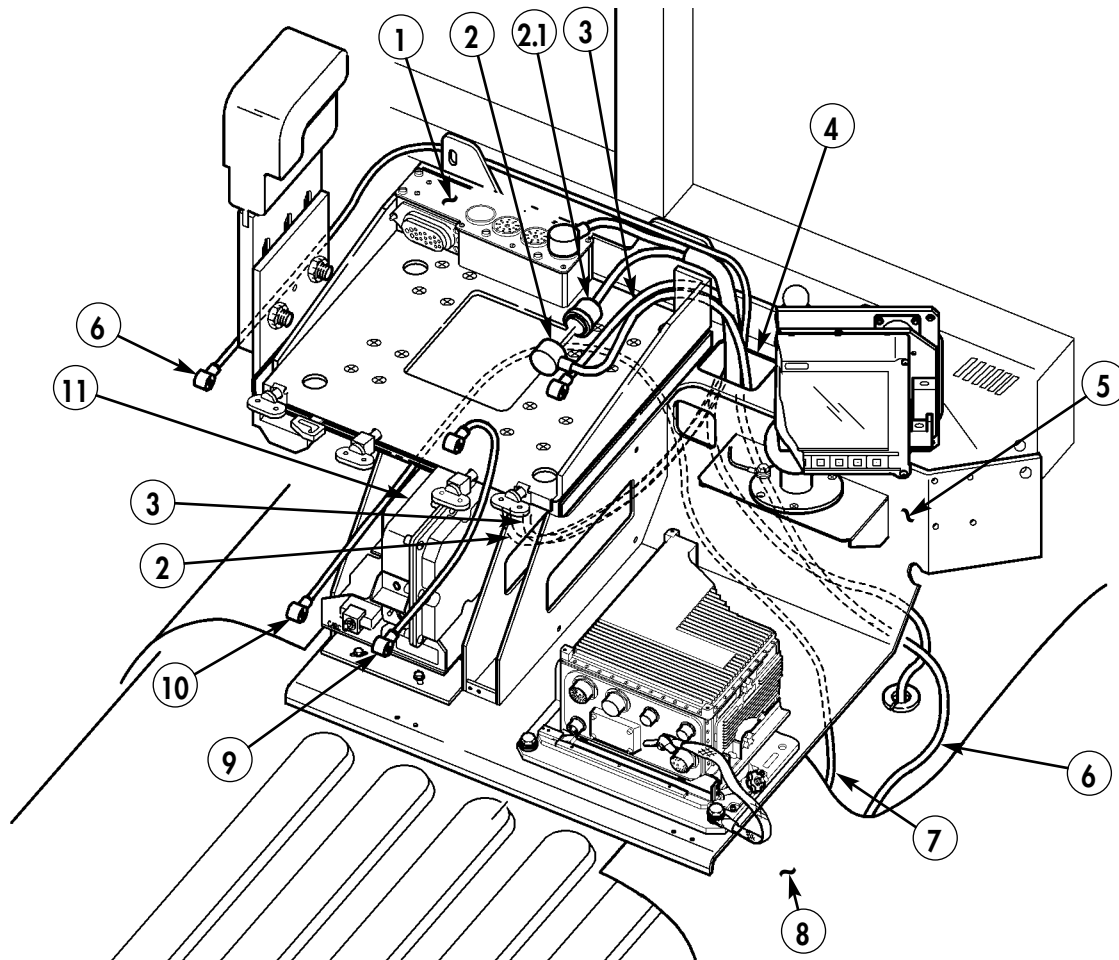

6. ANTENNA CABLE - A3014031-17 - QTY. 1
 7. ANTENNA CABLE - A3014031-8 - QTY. 1
 9. ANTENNA CABLE - A3014032-3 - QTY. 1

Figure 5-68.

- 24-6.** Route two antenna cables (7) and (6) along right rear seat/utility area with four self-tapping screws (12) and loop clamps (13).
- 24-7.** Route two antenna cables (7) and (6) through right wheelwell/utility area with existing grommet, retainer, screws, and plain-assembled nuts. (Refer to TM 9-2320-280-20.)

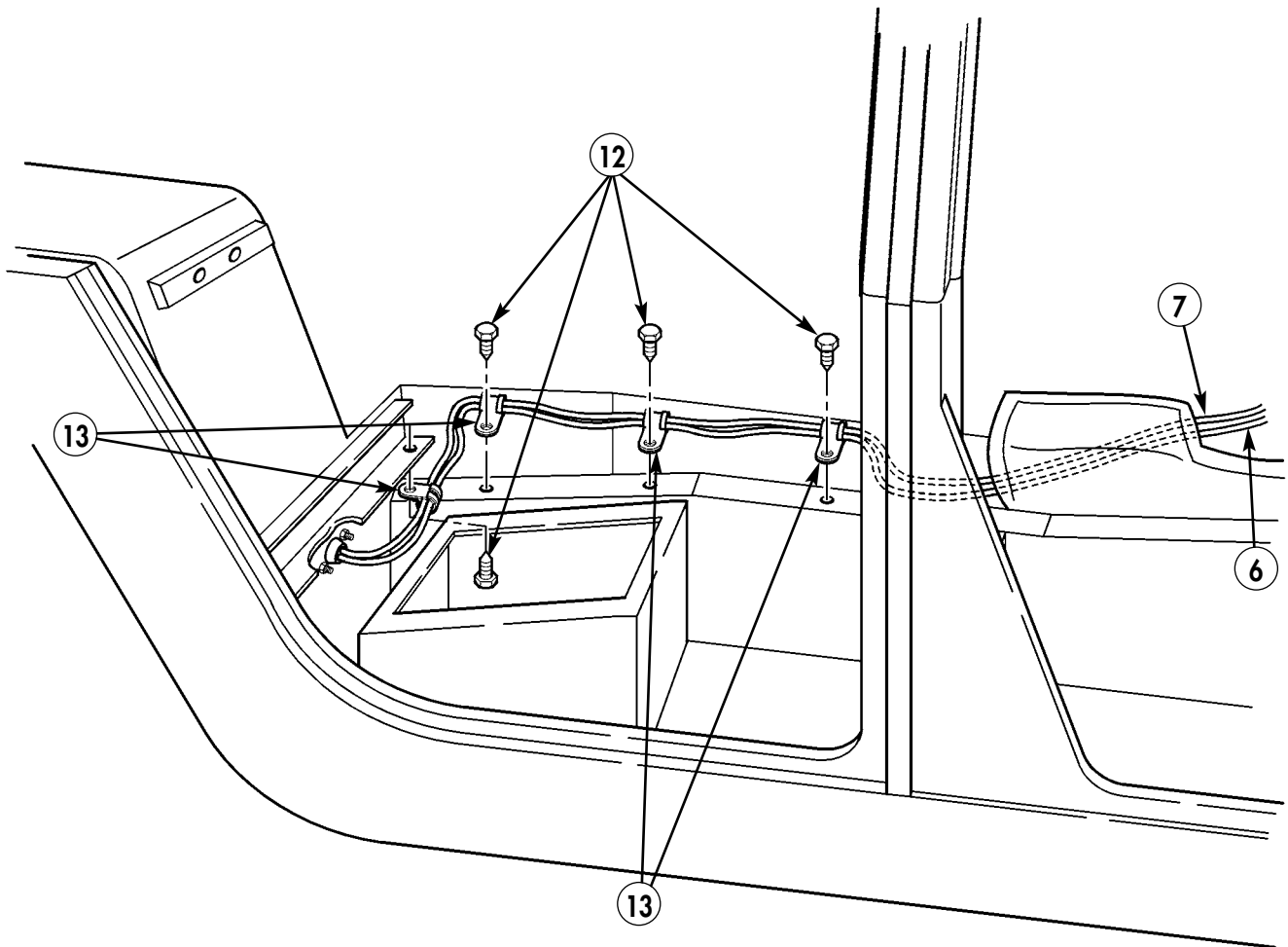

- 12. SELF-TAPPING SCREW - 9421073 - QTY. 4**
15. LOOP CLAMP - MS21333-69 - QTY. 4

Figure 5-69.

- 24-8. Route two antenna cables (7) and (6) along front wheelwell seam (16) and along front (14), intermediate (35), and rear (33) cargo bed supports. Secure with two self-tapping screws (15), loop clamps (16), screw (20), loop clamp (13), nut (15), and existing self-tapping screw (18) and loop clamp (34).
- 24-9. Route antenna cable (7) along taillight wiring harness with two existing loop clamps (27) and (26), self-tapping screws (18), and lockwashers (25).
- 24-10. Route antenna cable (7) to antenna base (32) with existing loop clamp (19), nut (23), lockwasher (22), washer (21), and screw (20).
- 24-11. Attach antenna cable (7) to antenna base (32).
- 24-12. Coil excess antenna cable (7) and secure to inside of taillight closeout cover with tiedown strap (24).
- 24-13. Attach cover plate (31) to offset antenna mount (28) with screws (29) and washers (30).

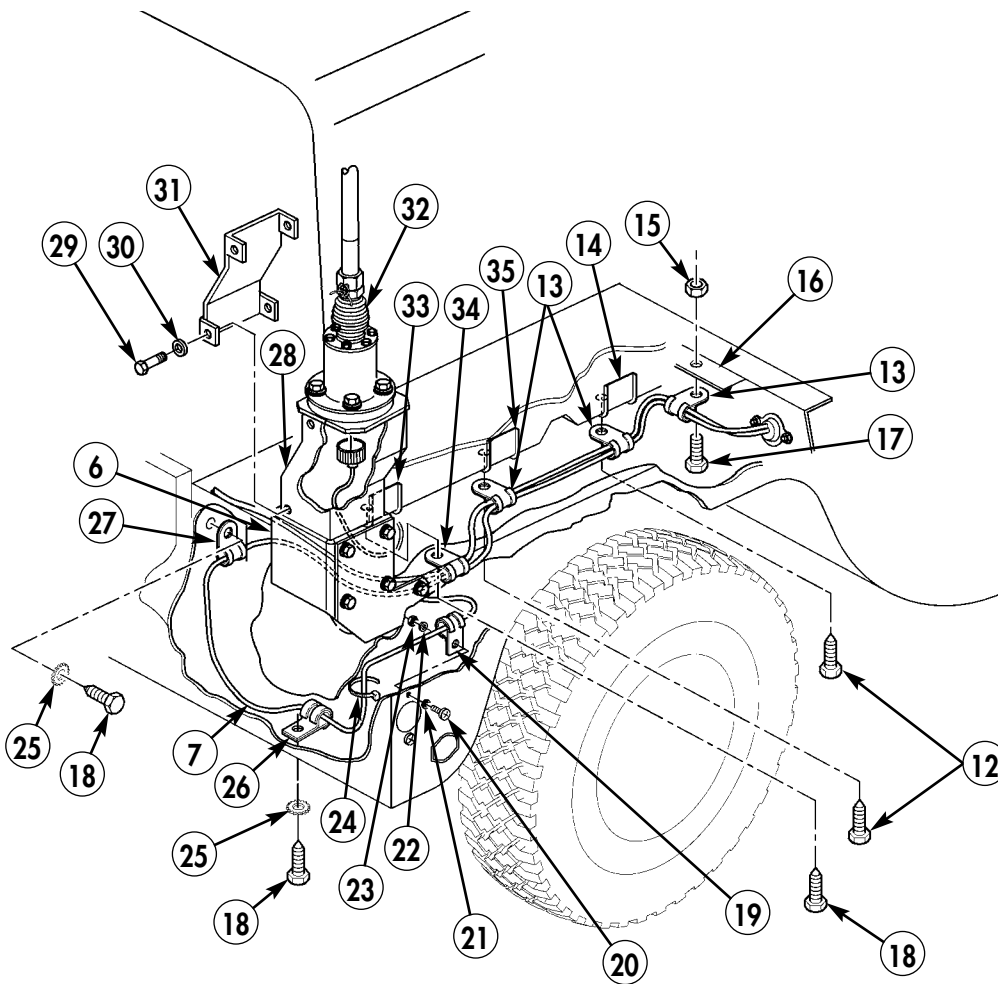

- 12. SELF-TAPPING SCREW - 9421073 - QTY. 2
- 13. LOOP CLAMP - MS21333-69 - QTY. 3
- 15. NUT - MS35650-302 - QTY. 1
- 17. SCREW - MS35224-65 - QTY. 1
- 24. TIEDOWN STRAP - MS3367-1-0 - QTY. A/R
- 29. SCREW - MS90725-30 - QTY. 4
- 30. WASHER - MS27183-12 - QTY. 4

Figure 5-70.

- 24-14. Route antenna cable (6) along existing taillight wiring harness (44) on rear cargo bed support (33) and secure with four existing loop clamps (45), (46), (47), (48), and existing self-tapping screws (40).
- 24-15. Route antenna cable (6) along existing taillight wiring harness on left-side frame rail with three existing loop clamps (43), (42), (48), and existing self-tapping screws (40) and lockwashers (41).
- 24-16. Route antenna cable (6) to antenna base (36) with existing loop clamp (37), screw (53), lockwasher (38), and nut (39).
- 24-17. Attach antenna cable (6) to antenna base (36).
- 24-18. Coil excess antenna cable (6) and secure to inside of taillight closeout cover with tiedown strap (49).
- 24-19. Attach cover plate (50) to offset antenna mount (54), with screws (51) and washers (52).

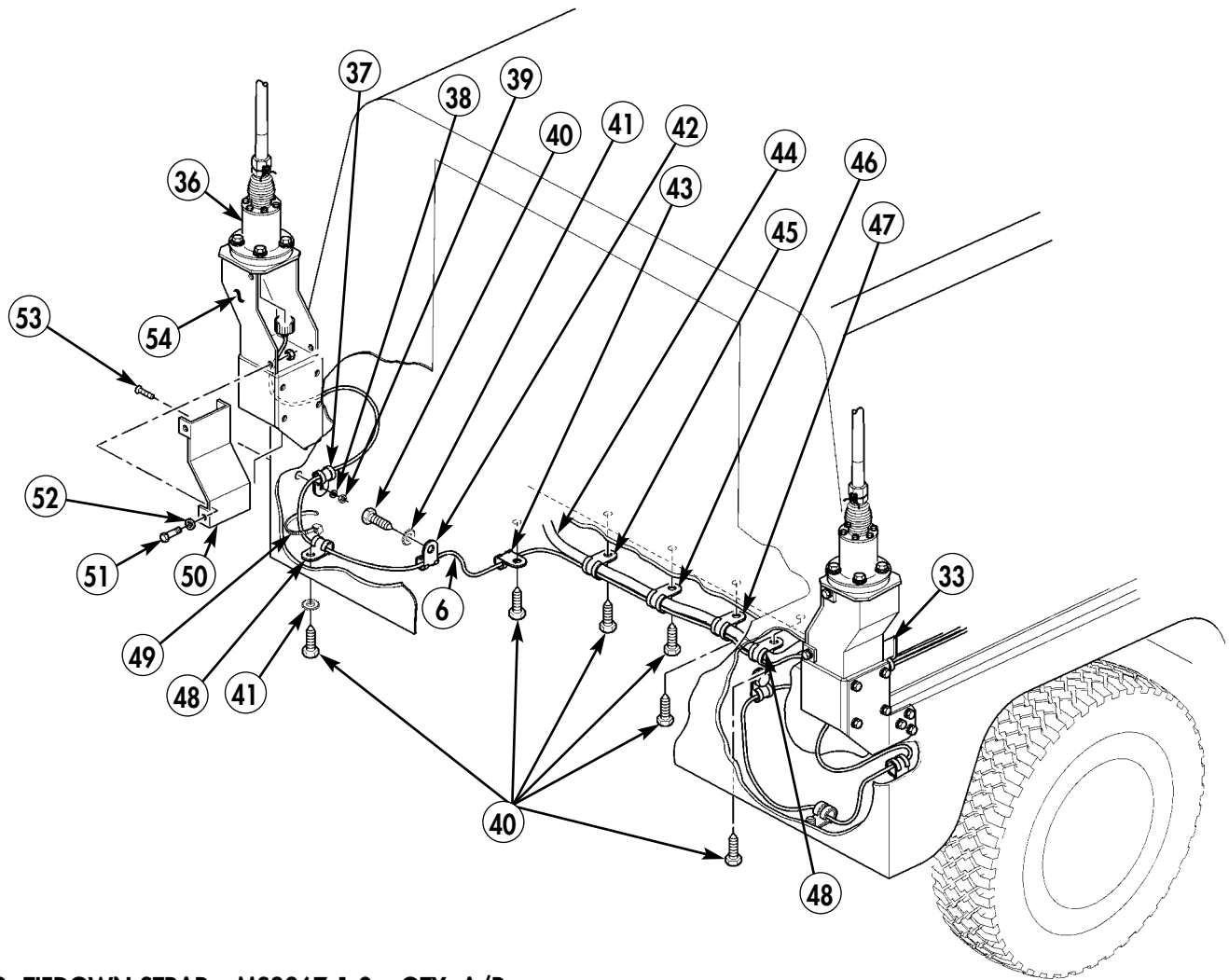

- 49. TIEDOWN STRAP – MS3367-1-0 – QTY. A/R
- 51. SCREW – MS90725-30 – QTY. 4
- 52. WASHER – MS27183-12 – QTY. 4

Figure 5-71.

Section XXV. PLGR BRACKET INSTALLATION

- 25-1. Install PLGR bracket (11) on integrated rack (1) with four screws (12).
- 25-2. Locate, mark, and drill one 0.201-in. diameter hole (10) in right-side engine tunnel (9).
- 25-3. Remove paint from vicinity of hole (4) on integrated rack (1) and hole (10) on right-side engine tunnel (9). Apply anti-seize compound as required.
- 25-4. Fabricate ground strap (5) from 8.00-in. length of braided wire and two terminal lugs.
- 25-5. Install ground strap (5) on integrated rack (1) with capscrew (6), three lockwashers (2), and nut (3).
- 25-6. Install ground strap (5) on right-side engine tunnel (9) with self-tapping screw (8) and two lockwashers (7).

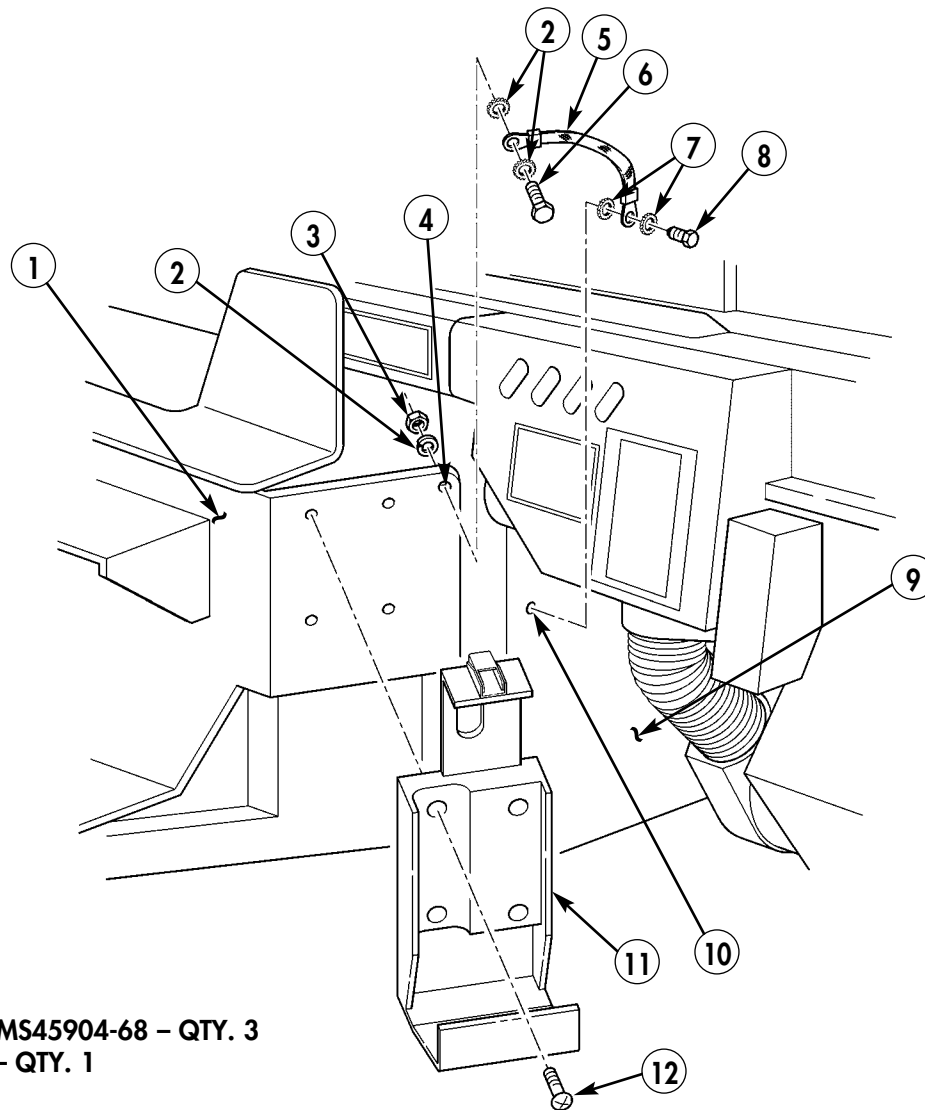

- 2. LOCKWASHER – MS45904-68 – QTY. 3
- 3. NUT – 9419143 – QTY. 1
- 5. GROUND STRAP
 - BRAIDED WIRE – AA59569F30T0375 – QTY. A/R
 - TERMINAL LUG – MS20659-129 – QTY. 2
- 6. CAPSCREW – B1821BH025C100N – QTY. 1
- 7. LOCKWASHER – MS35338-43 – QTY. 2
- 8. SELF-TAPPING SCREW – 9426241 – QTY. 1
- 11. PLGR BRACKET – 986-0645-001 – QTY. 1
- 12. SCREW – MS35206-263 – QTY. 4

Figure 5-72.

Section XXVI. PLGR ANTENNA AND CABLE INSTALLATION (WITHOUT BOLT-ON ARMOR)

26-1. Remove two plugs (1) from outer right-side windshield frame (3).

NOTE

Drilled holes on inside and outside of windshield frame should align to allow routing of PLGR cable through windshield frame.

26-2. Locate, mark, and drill one 0.375-in. diameter hole (2) in outer right-side windshield frame (3).

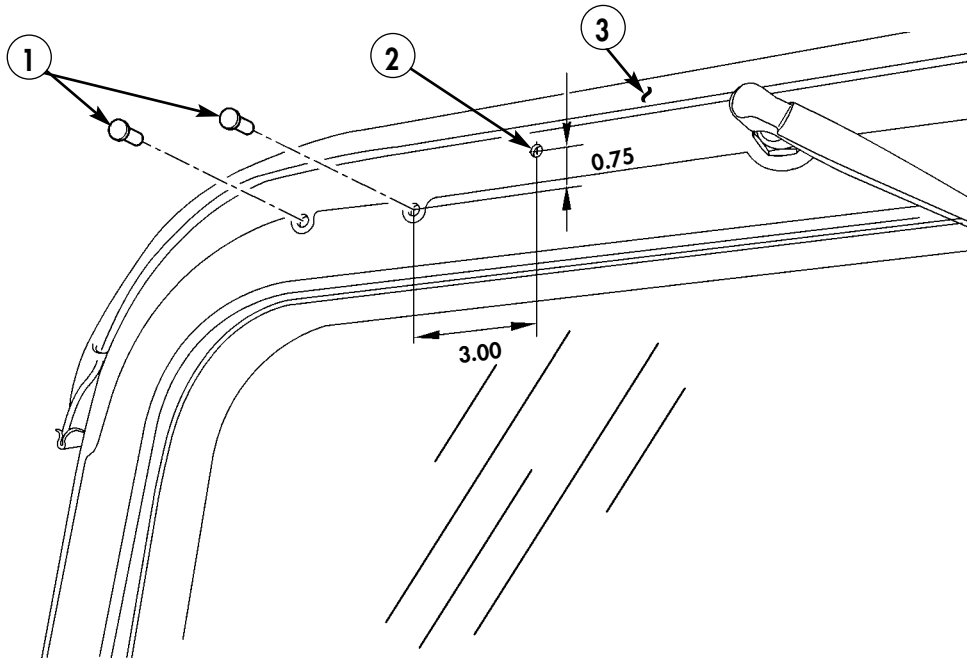

Figure 5-73.

26-3. Locate, mark, and drill one 0.375-in. diameter hole (4) in inner right-side windshield frame (5).

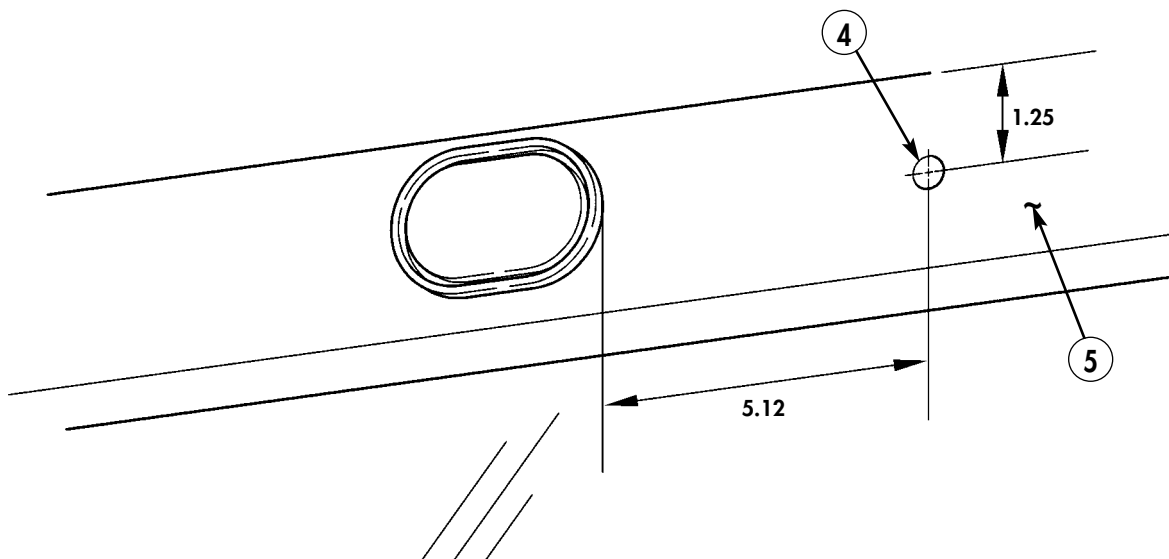
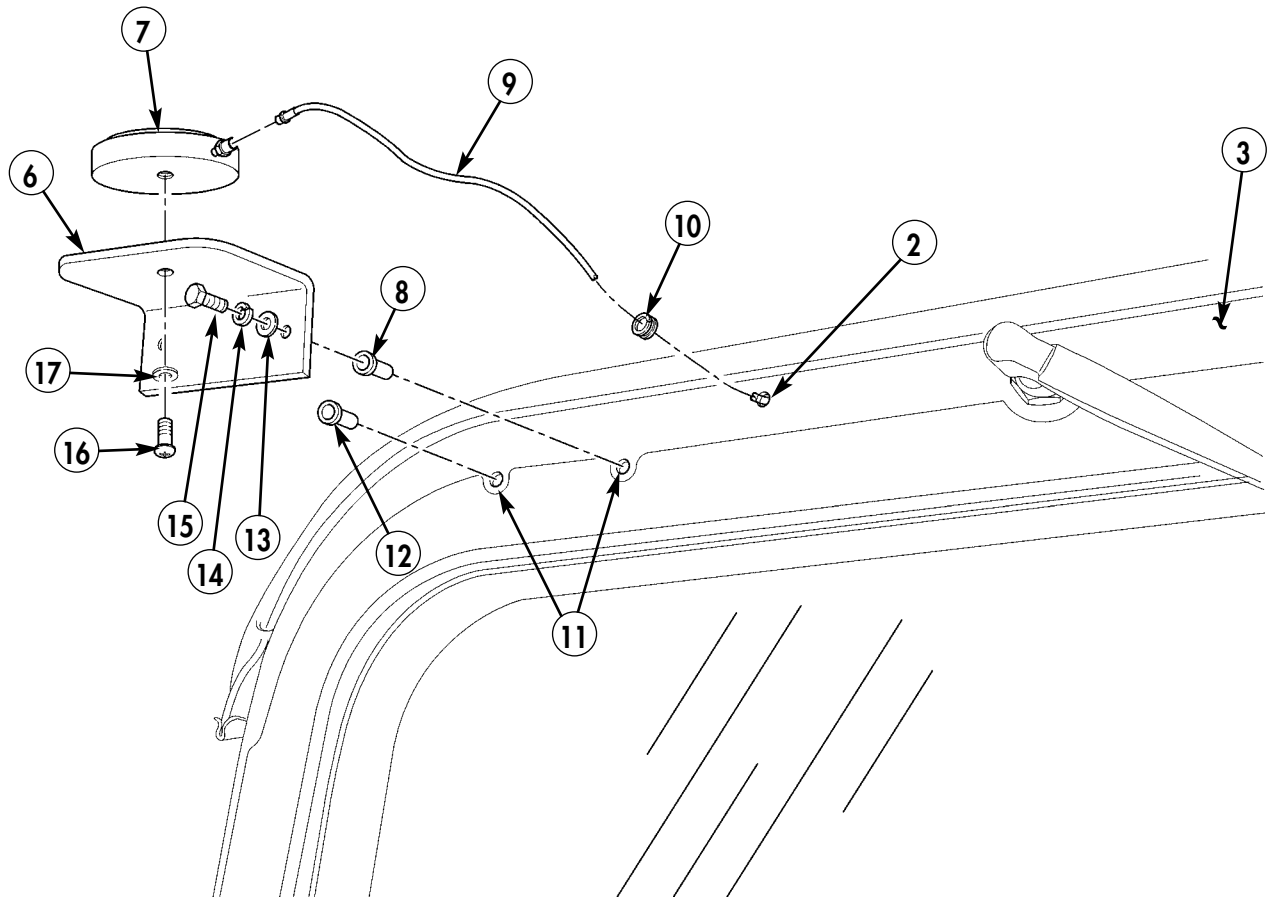

Figure 5-74.

- 26-4. Pull PLGR antenna cable (9) through hole (2) in outer right-side windshield frame (3).
- 26-5. Split one side of grommet (10), place on PLGR antenna cable (9), and insert grommet (10) in hole (2) in outer right-side windshield frame (3).
- 26-6. Install wellnuts (8) and (12) in holes (11).
- 26-7. Install PLGR antenna mount bracket (6) on outer right-side windshield frame (3) with two washers (13), lockwashers (14), and capscrews (15).
- 26-8. Install PLGR antenna (7) on PLGR antenna mount bracket (6) with washer (17) and screw (16).
- 26-9. Attach PLGR antenna cable (9) to PLGR antenna (7).



- 6. PLGR ANTENNA MOUNT BRACKET - 12480578 - QTY. 1
- 7. PLGR ANTENNA - AT575-030 - QTY. 1
- 8. WELLNUT - 12339397-6 - QTY. 1
- 9. PLGR ANTENNA CABLE - 426-0141-050 - QTY. 1
- 10. GROMMET - MS35489-143 - QTY. 1
- 12. WELLNUT - 12339397-3 - QTY. 1
- 13. WASHER - 9414920 - QTY. 2
- 14. LOCKWASHER - MS35338-44 - QTY. 2
- 15. CAPSCREW - B1821BH025C125N - QTY. 2
- 16. SCREW - 160035 - QTY. 1
- 17. WASHER - 9417373 - QTY. 1

Figure 5-75.

- 26-10.** Split one side of grommet (10) and place on PLGR antenna cable (9).
- 26-11.** Insert PLGR antenna cable (9) and grommet (10) in hole (4) in inner-right windshield frame (5).

NOTE

If sun visor kit has not been installed, perform steps 26-12 through 26-14. If sun visor has been installed, perform steps 26-15 and 26-16.

- 26-12.** Locate, mark, and drill one 0.390-in. diameter hole (21) in windshield frame (5).
- 26-13.** Install insert (22) in hole (21).

NOTE

Perform step 26-14 only if sun visor kit has been installed.

- 26-14.** Route PLGR antenna cable (9) along inner right windshield frame (5) with loop clamp (20), lockwasher (19), and capscrew (18).
- 26-15.** Remove capscrew (18) and lockwasher (19).
- 26-16.** Route PLGR antenna cable (9) along inner-right windshield frame (5) with loop clamp (20), lockwasher (19), and capscrew (18).

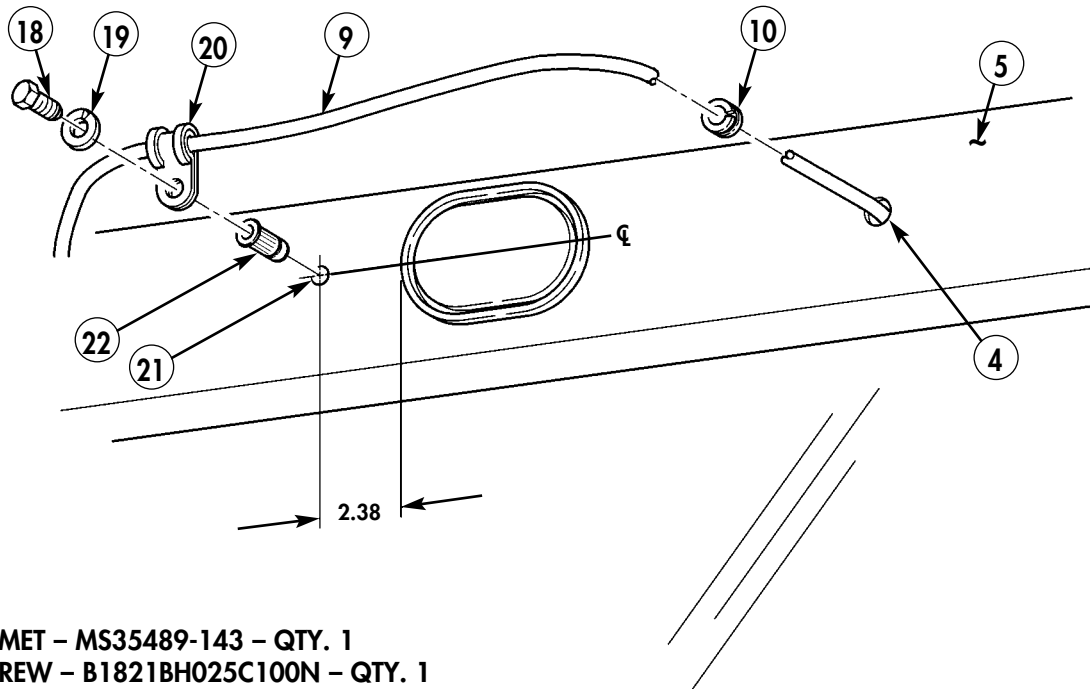

- 10. GROMMET – MS35489-143 – QTY. 1**
18. CAPSCREW – B1821BH025C100N – QTY. 1
19. LOCKWASHER – 120380 – QTY. 1
20. LOOP CLAMP – MS21333-96 – QTY. 1
22. INSERT – 12446871-2 – QTY. 1

Figure 5-76.

- 26-17. Locate, mark, and drill two 0.147-in. diameter holes (27) in windshield center frame (28).
- 26-18. Route PLGR antenna cable (9) along windshield center frame (28) with two self-tapping screws (25), loop clamps (26) and (20), existing screw (23), and washer (24).

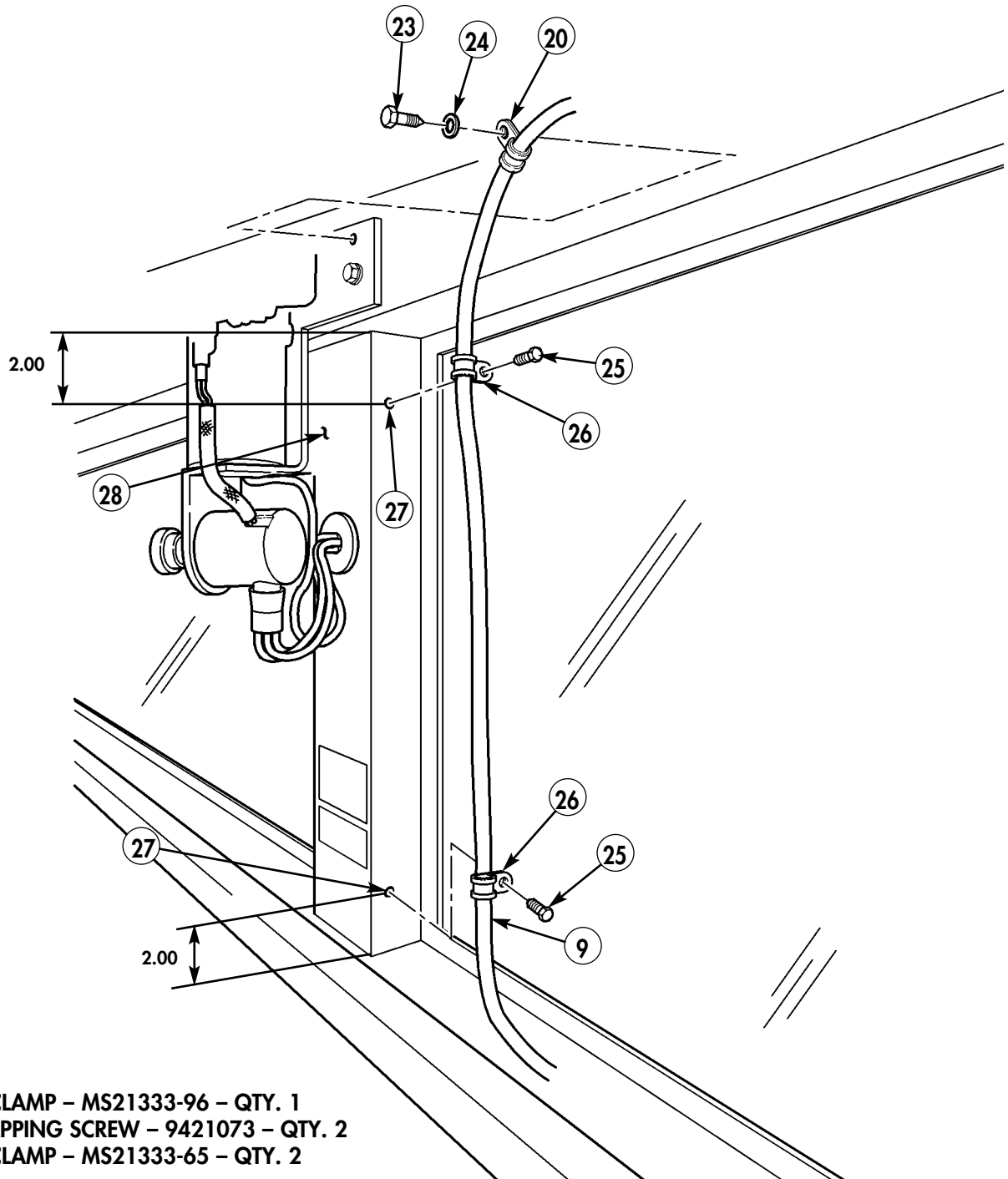

- 20. LOOP CLAMP – MS21333-96 – QTY. 1
- 25. SELF-TAPPING SCREW – 9421073 – QTY. 2
- 26. LOOP CLAMP – MS21333-65 – QTY. 2

Figure 5-77.

- 26-19. Locate, mark, and drill one 0.147-in. hole (35) in top of windshield frame (30).
- 26-20. Route PLGR antenna cable (9) on top of windshield frame (30) and secure with loop clamp (26) and self-tapping screw (25).
- 26-21. Route PLGR antenna cable (9) down through center access hole (29) of integrated rack (31), and coil excess antenna cable (9) under integrated rack (31).
- 26-22. Route PLGR power cable (33) from PLGR installation mount (32) to right-side tunnel insulation (34).

NOTE

Loosen right-side tunnel insulation before performing step 26-23.
(Refer to TM 9-2320-280-20.)

- 26-23. Route PLGR power cable (33) under edge of right-side tunnel insulation (34) to 24V terminal bar at cab enclosure panel.

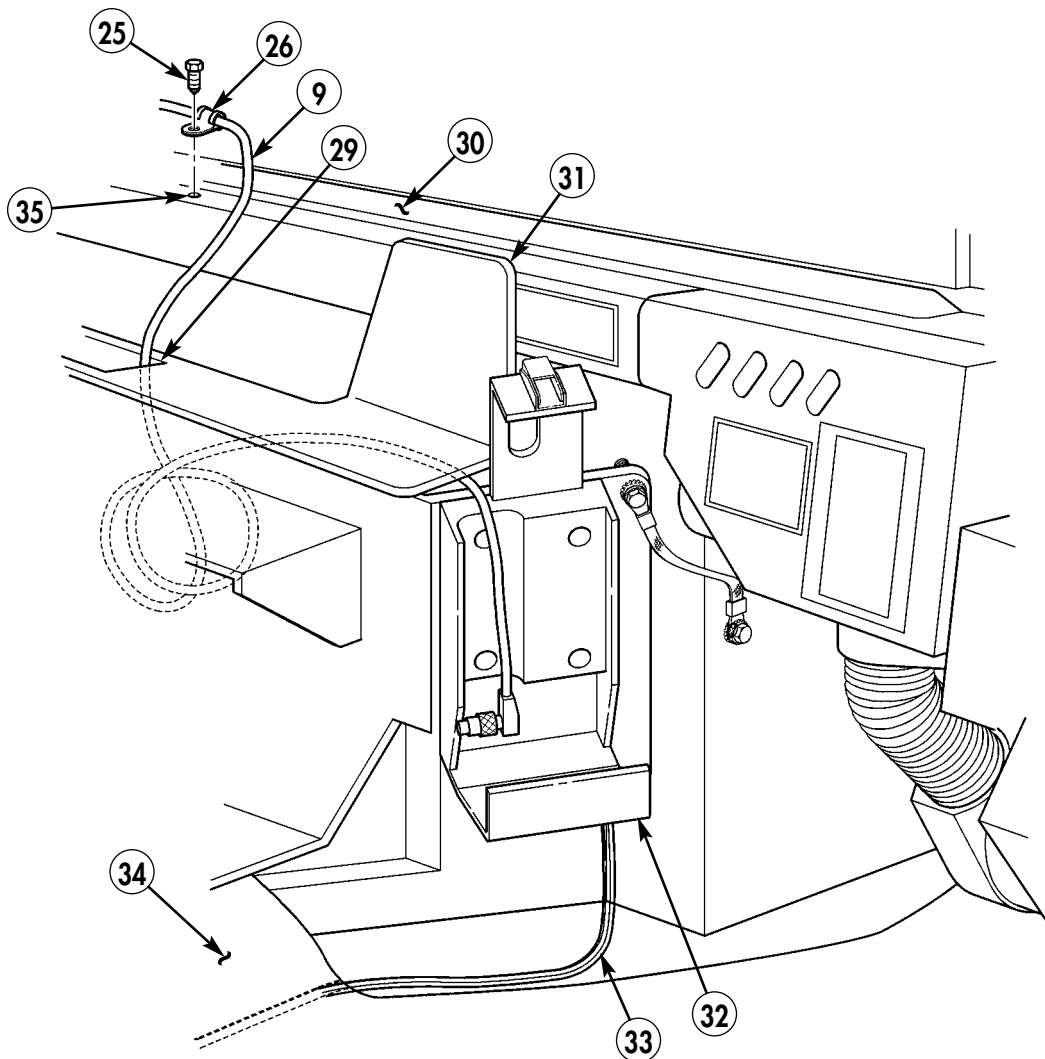

- 25. SELF-TAPPING SCREW - 9421073 - QTY. 1
- 26. LOOP CLAMP - MS21333-65 - QTY. 1
- 33. PLGR POWER CABLE - 9728558-10 - QTY. 1

Figure 5-78.

NOTE

PLGR power cable positive lead insulation is ribbed.

- 26-24. Attach shrink tubing (39) and terminal lugs (37) and (43) to PLGR power cable negative lead (42) and PLGR power cable positive lead (40). (Refer to TM9-2320-280-20 for terminal connector repair.)
- 26-25. Attach PLGR power cable positive lead (40) to 24V terminal board (45), located on cab enclosure panel (36), with existing nut (38).
- 26-26. Attach PLGR power cable negative lead (42) to ground strap (44), located on cab enclosure panel (36), with existing nut (38).
- 26-27. Coil excess positive and negative power leads (40) and (42), place beneath ground strap (44), and secure with tiedown strap (41).

NOTE

Ensure all excess antenna cable is inside cab of vehicle.

- 26-28. Coil excess antenna cable and store under integrated rack using tiedown strap as necessary. (Refer to Figure 5-78.)
- 26-29. Install right-side tunnel insulation. (Refer to TM 9-2320-280-20.)

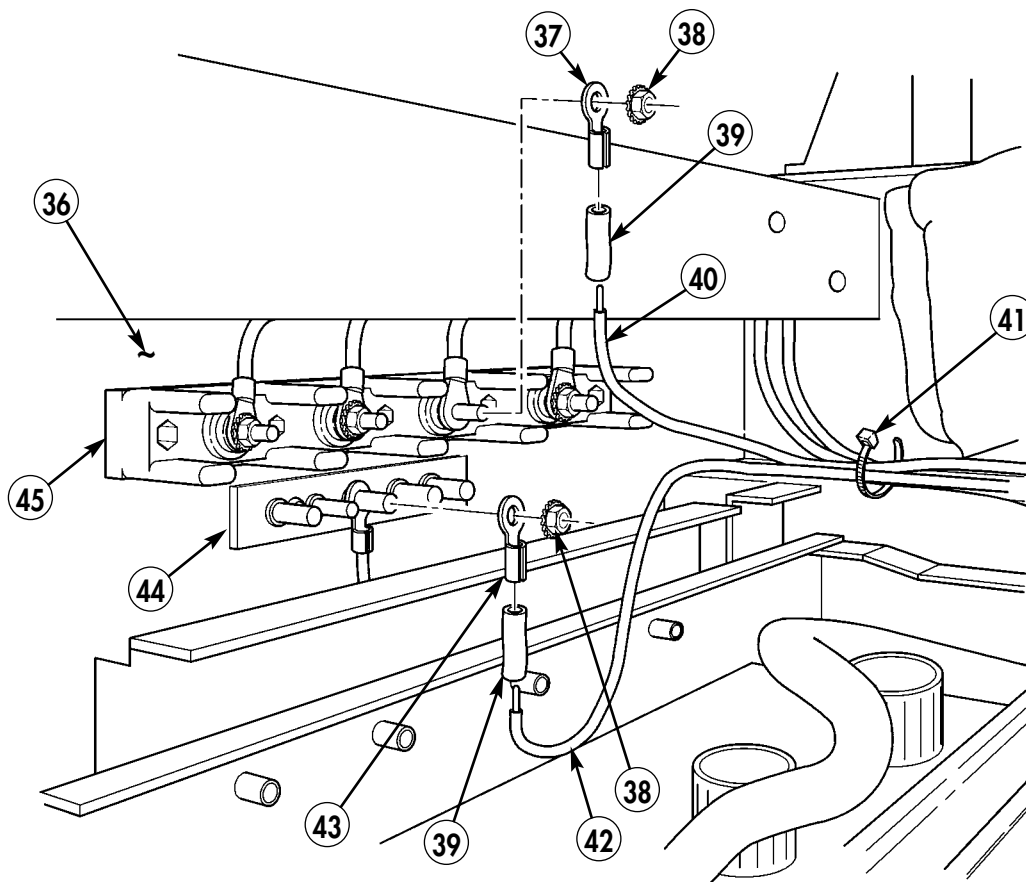

- 37. TERMINAL LUG – 7728780 – QTY. 1
- 39. SHRINK TUBING – MS23053/4-302-0 – QTY. A/R
- 41. TIEDOWN STRAP – MS3367-1-0 – QTY. A/R
- 43. TERMINAL LUG – 7728777 – QTY. 1

Figure 5-79.

Section XXVII. LOUDSPEAKER CABLES INSTALLATION

- 27-1.** Connect speaker cables (2) to loudspeakers (1).
- 27-2.** Secure cables (2) with tiedown strap (3).
- 27-3.** Route speaker cables (2) to integrated rack (4).

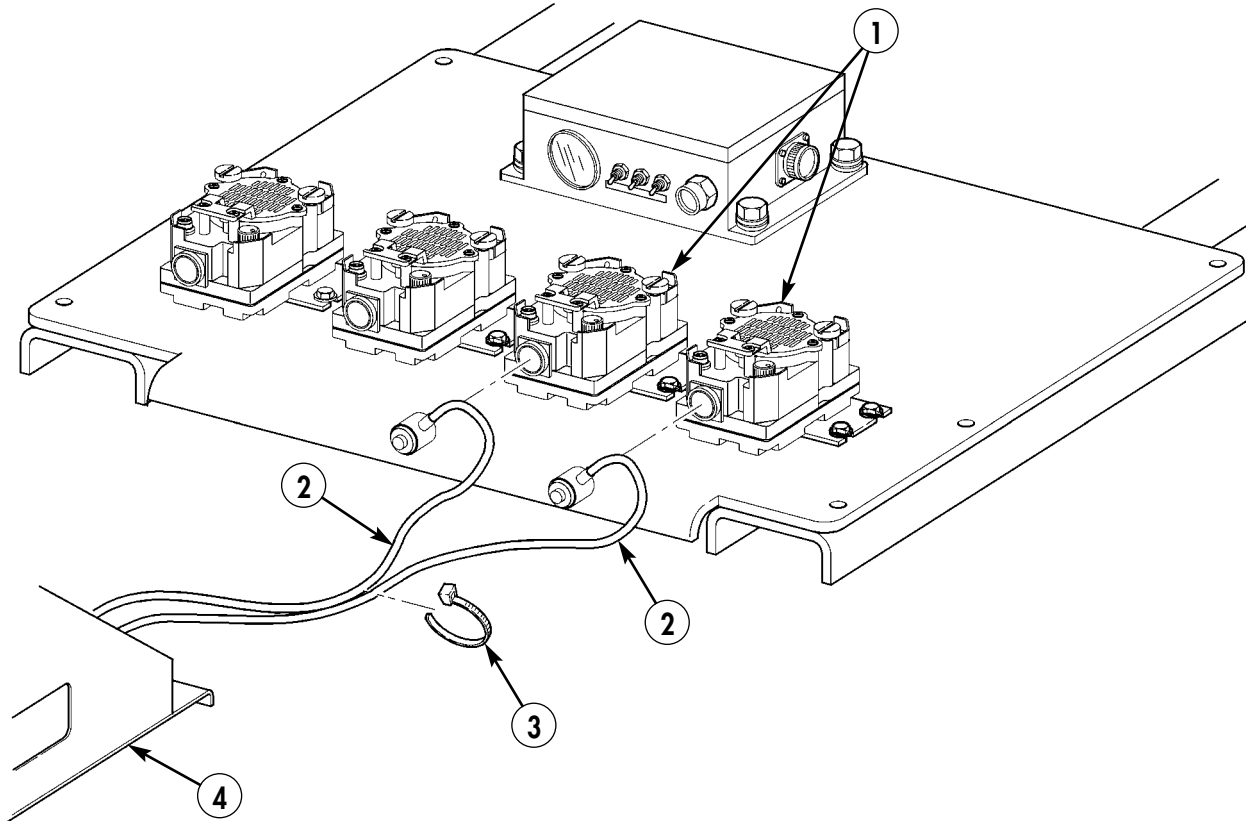

- 2. LOUDSPEAKER CABLE – A3014038-3 – QTY. 2**
- 3. TIEDOWN STRAP – MS3367-1-0 – QTY. 1**

Figure 5-80.

27-4. Route speaker cables (2) through center access hole (6) in integrated rack (4) and behind SINGARS mounting base MT-6352/VRC (5).

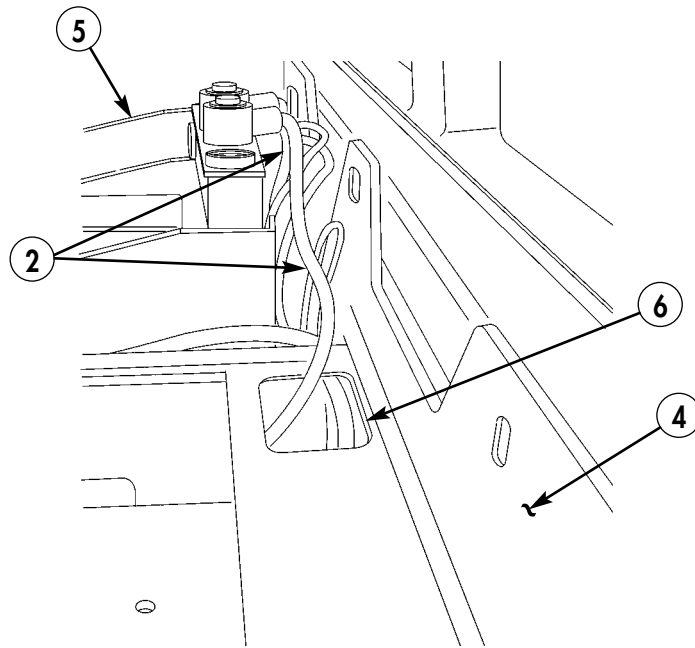

Figure 5-81.

27-5. Mount speaker cables (2) on SINGARS mounting base power distribution (7).

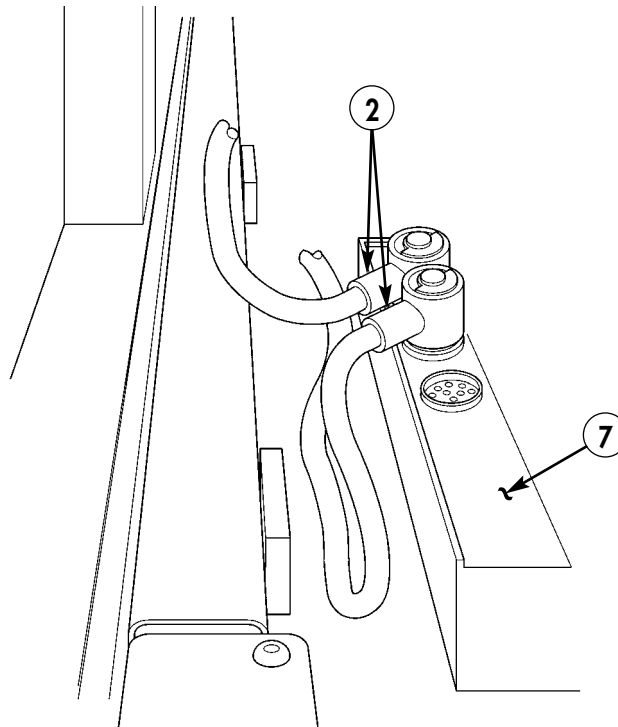
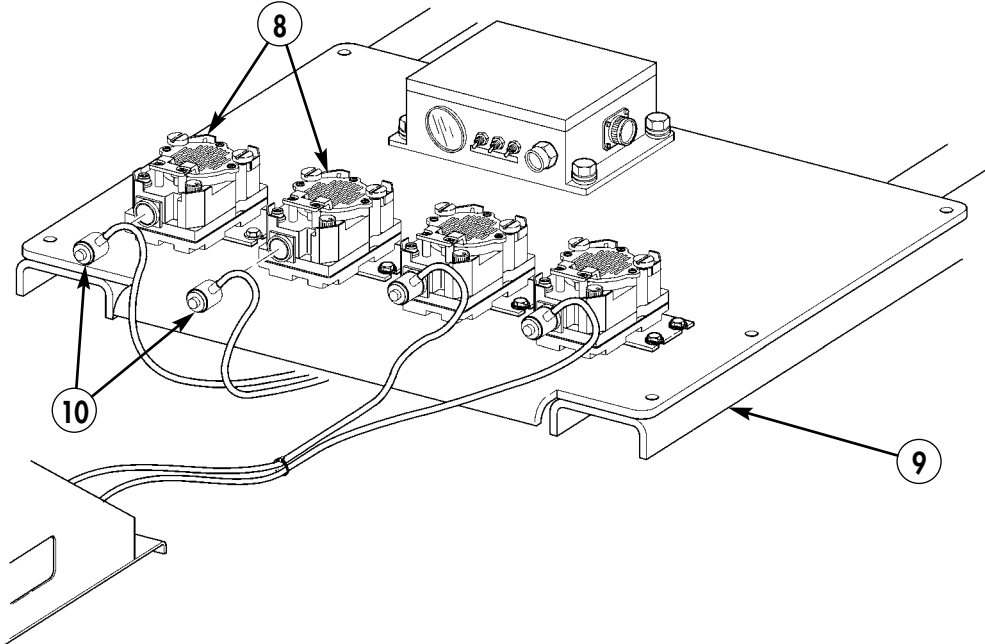

Figure 5-82.

27-6. Connect two speaker cables (10) to two loudspeakers (8). Route two speaker cables (10) under lower shelf (9).



10. LOUDSPEAKER CABLE – A3014038-3 – QTY. 2

Figure 5-83.

27-7. Connect two speaker cables (10) to SINCGARS mounting base MT-6352/VRC (5).

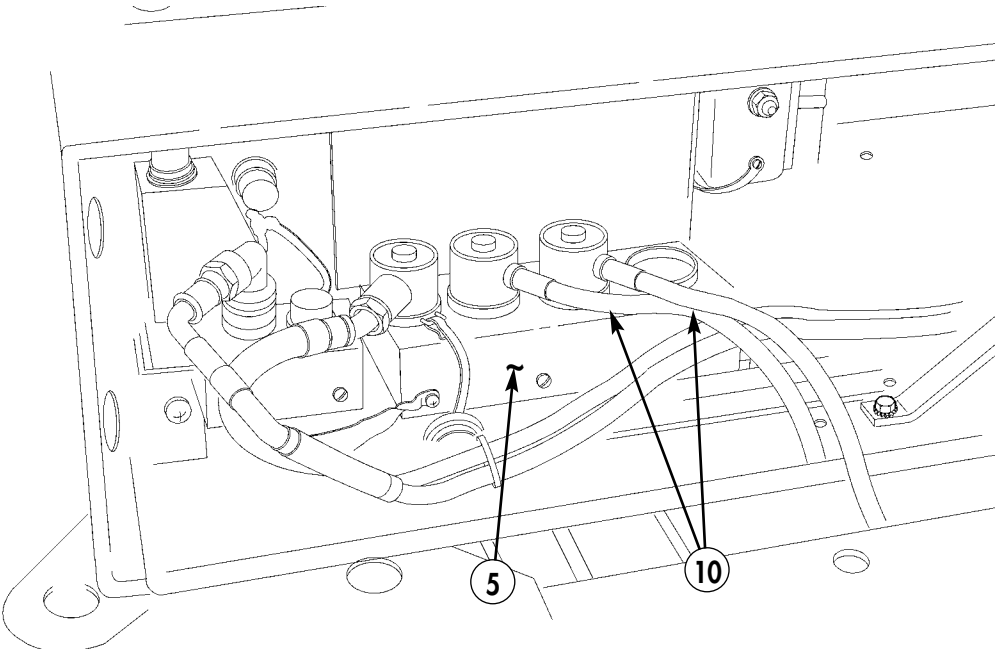
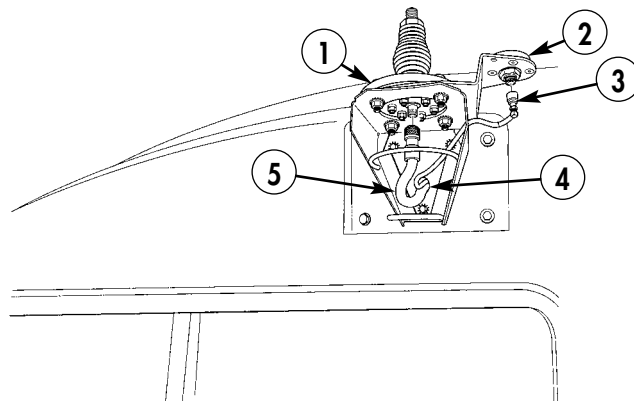

Figure 5-84.

Section XXVIII. EPLRS ANTENNA CABLE AND NTDR ANTENNA CABLE INSTALLATION

- 28-1. Connect NTDR antenna cable (3) to NTDR antenna (2).
- 28-2. Connect EPLRS antenna cable (5) to EPLRS antenna (1).
- 28-3. Route NTDR antenna cable (3) and EPLRS antenna cable (5) through hole in bracket (4) and fiberglass body (8). Secure with clamp (7) and self-tapping screw (6).
- 28-4. Route cable to B-pillar (9). Secure with clamp (7) and self-tapping screw (6).
- 28-5. Route cable down B-pillar (9) to rear seatwell (11).
- 28-6. Route cable through rear seatwell (11) to C-beam (10).
- 28-7. Route cable along C-beam (10) to multi-net rack (16).
- 28-8. Route cable through hole in frame and through holes in side of multi-net rack (16).
- 28-9. Route EPLRS antenna cable (5) to vicinity of EPLRS mount (15).
- 28-10. Route NTDR antenna cable (3) to vicinity of NTDR mount (17).
- 28-11. Secure NTDR antenna cable (3) with three loop clamps (12), three screws (14), six washers (13), and three nuts (18).



- 3. NTDR ANTENNA CABLE – 8174914-7 – QTY. 1
- 5. EPLRS ANTENNA CABLE – SM-C-911480 – QTY. 1

Figure 5-85.

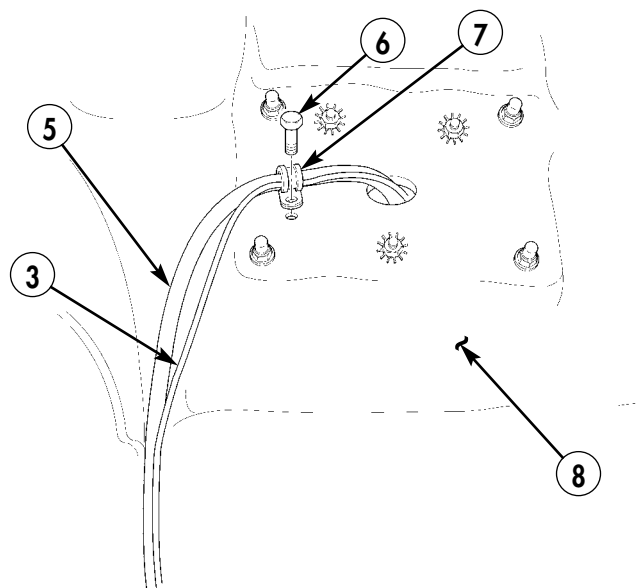

- 6. SELF-TAPPING SCREW – 9421073 – QTY. 1
- 7. LOOP CLAMP – MS21333-71 – QTY. 1

Figure 5-86.

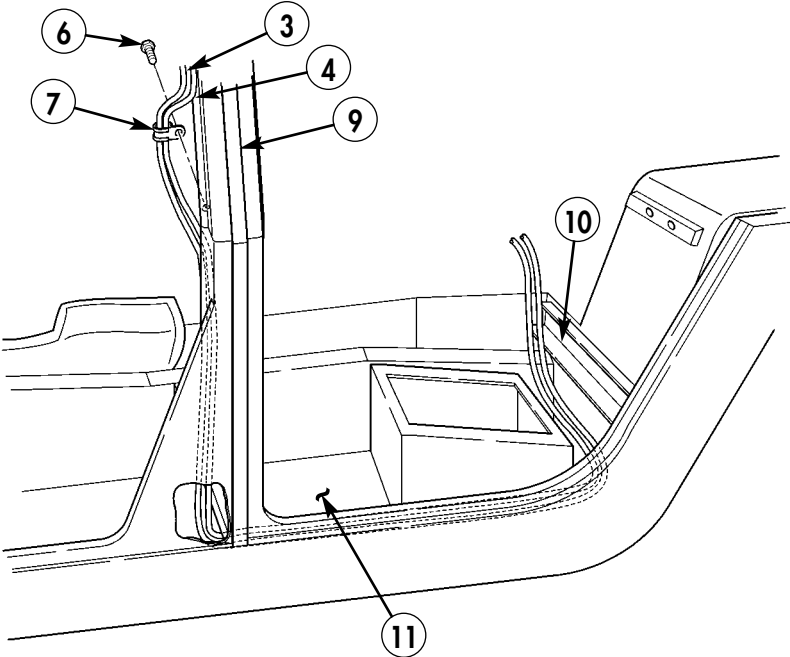

- 6. SELF-TAPPING SCREW - 9421073 - QTY. 1
- 7. LOOP CLAMP - MS21333-71 - QTY. 1

Figure 5-87.

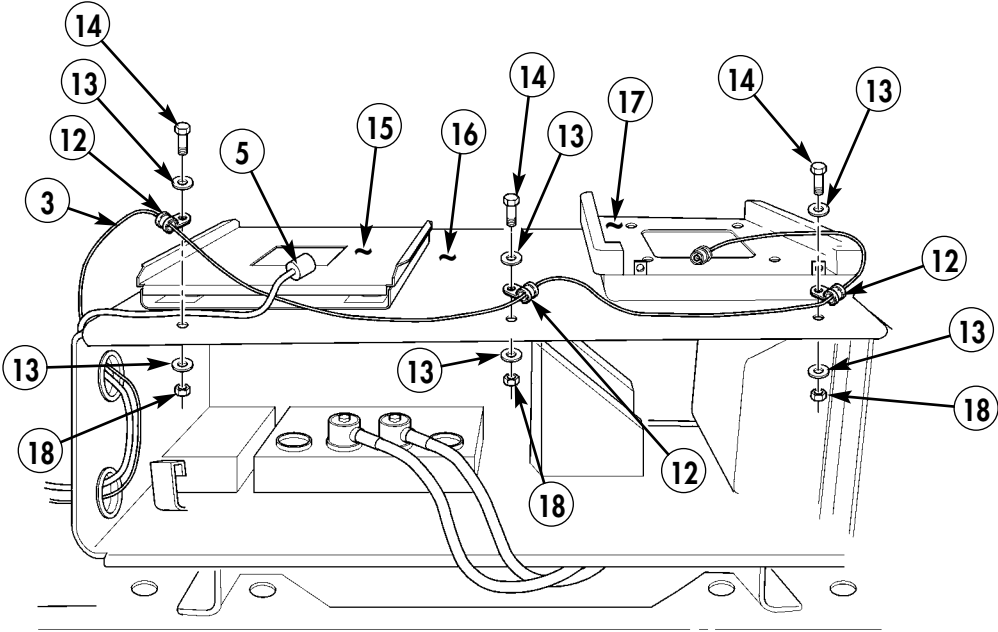

- 12. LOOP CLAMP - MS21333-67 - QTY. 3
- 13. WASHER - MS27183-8 - QTY. 6
- 14. SCREW - MS35207-265 - QTY. 3
- 15. NUT - MS35360-302 - QTY. 3

Figure 5-88.

Section XXIX. EPLRS POWER AND INC-EPUU CABLE INSTALLATION

- 29-1. Route INC-EPUU cable (1) and power cable (2) from mount unit (3) down behind multi-net rack (4) into tunnel (5).
- 29-2. Route power cable (2) under insulation to terminal board.
- 29-3. Route INC-EPUU cable (1) along tunnel (5) to integrated rack.

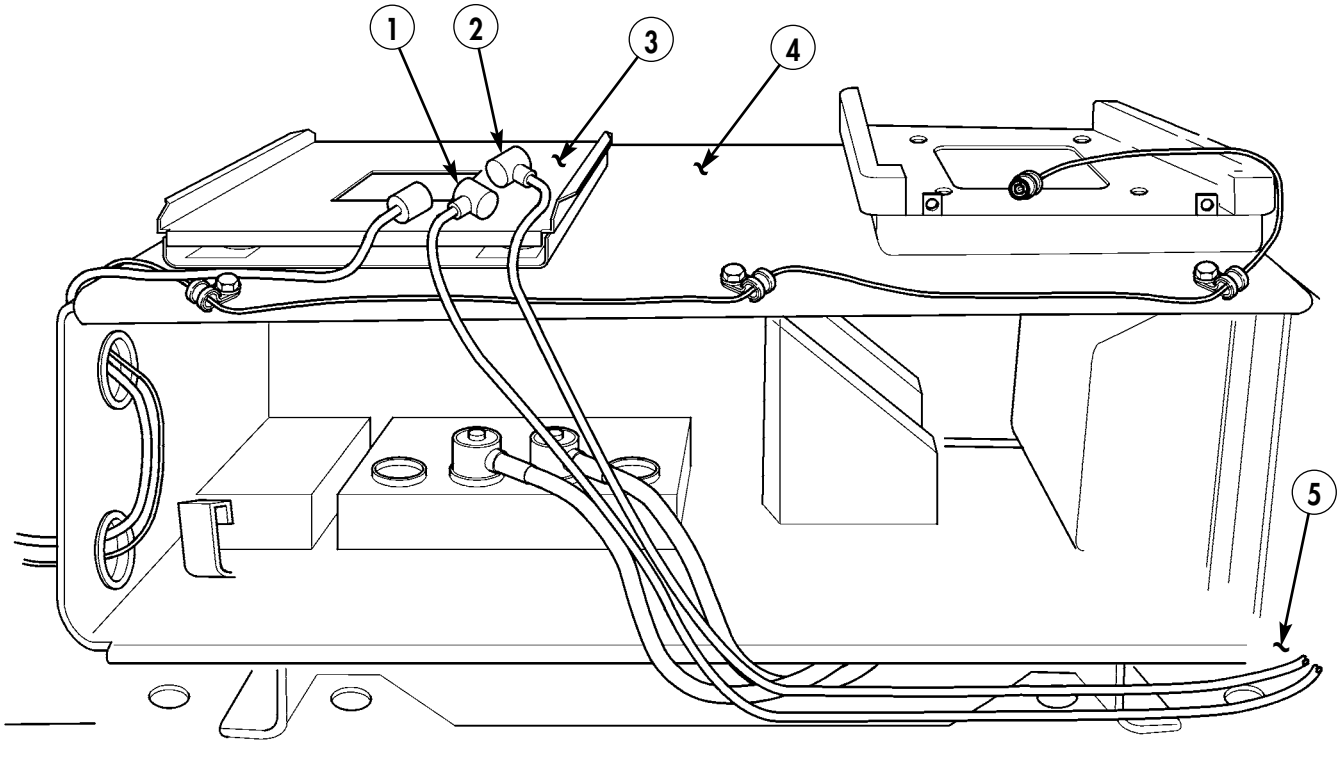

- 1. INC-EPUU CABLE - A3279383-2 - QTY. 1
- 2. POWER CABLE - A3004939 - QTY. 1

Figure 5-89.

NOTE

Previously installed cables for figure 5-90 have been removed for clarity.

- 29-4. Route INC-EPUU cable (1) through center access hole (7).
- 29-5. Route INC-EPUU cable (1) to SINCGARS mounting base MT-6352/VRC (6).
- 29-6. Coil excess INC-EPUU cable (1) under integrated rack (8).

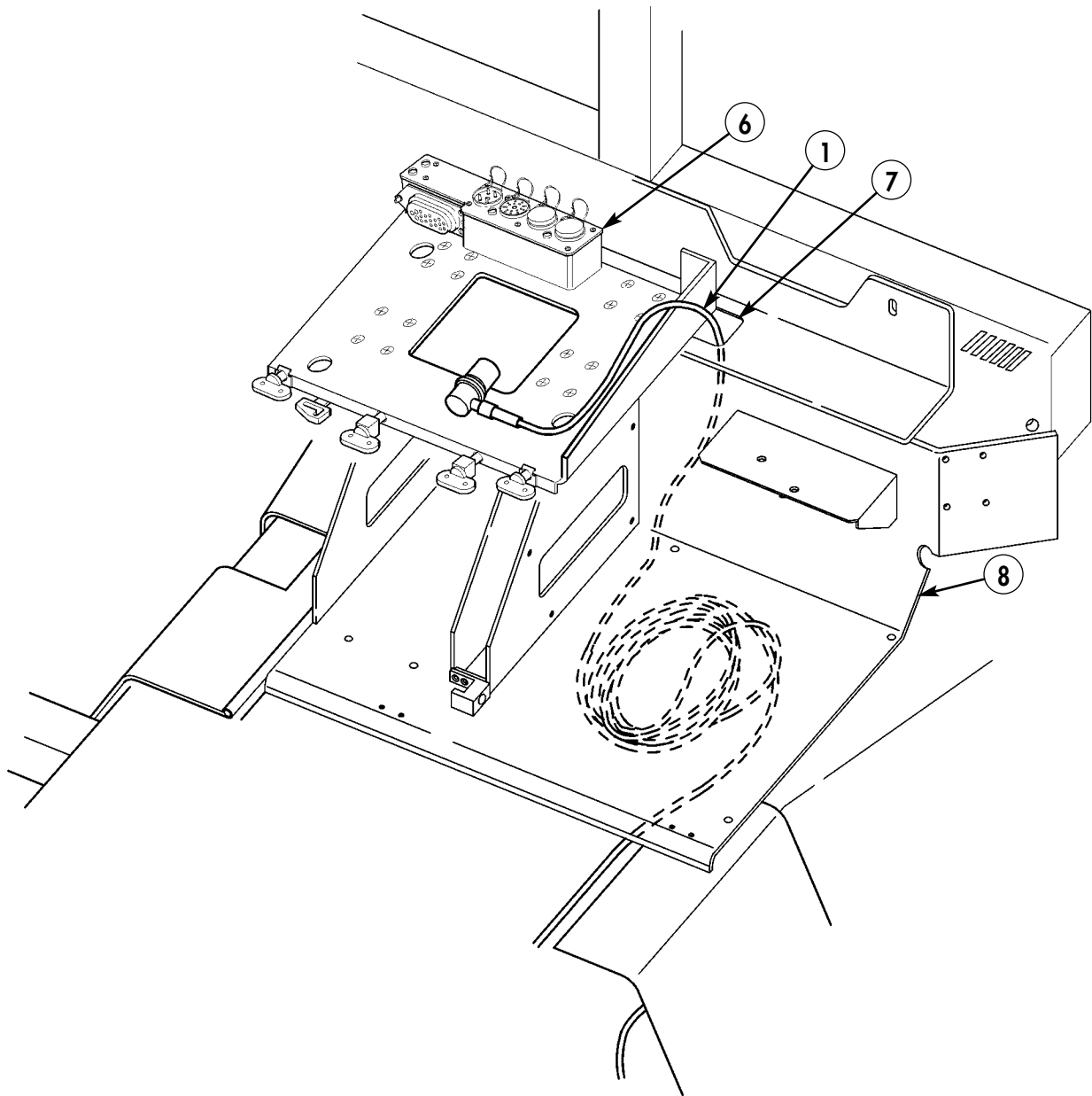
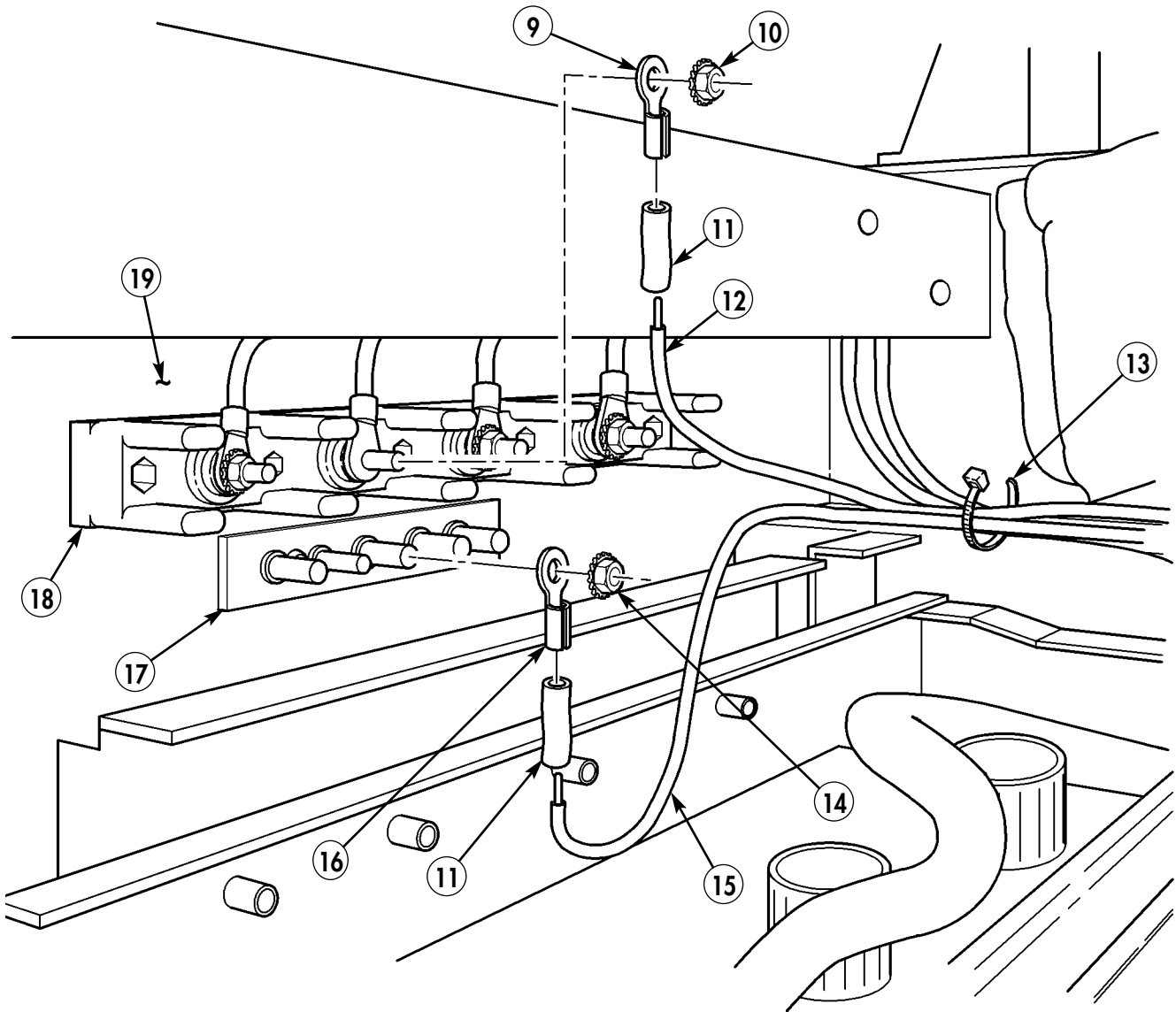

Figure 5-90.

- 29-7. Attach heat shrink tubing (11) and two terminal lugs (9) and (16) to power cable negative lead (15) and power cable positive lead (12). (Refer to TM 9-2320-280-20 for terminal connector repair.)
- 29-8. Connect power cable positive lead (12) to 24V terminal board (18), located on cab enclosure panel (19), with existing nut (10).
- 29-9. Connect power cable negative lead (15) to ground strap (17), located on cab enclosure panel (19), with existing nut (14). Secure leads (12) and (15) together with tiedown strap (13).



- 9. TERMINAL LUG - 7728780 - QTY. 1
- 11. SHRINK TUBING - MS23053/4-302-0 - QTY. A/R
- 13. TIEDOWN STRAP - MS3367-1-0 - QTY. A/R
- 16. TERMINAL LUG - 7728777 - QTY. 1

Figure 5-91.

Section XXX. NTDR POWER CABLE AND UHF CABLE INSTALLATION

- 30-1.** Route NTDR power cable (4) from mount (3), down behind multi-net rack (1), and into tunnel (5).
- 30-2.** Route NTDR power cable (4) along tunnel (5) into battery box.
- 30-3.** Route NTDR UHF cable (2) along multi-net rack (1) with existing clamps, screws, washers, and nuts.
- 30-4.** Route NTDR UHF cable (2) down behind multi-net rack (1) and to QEAM panel.

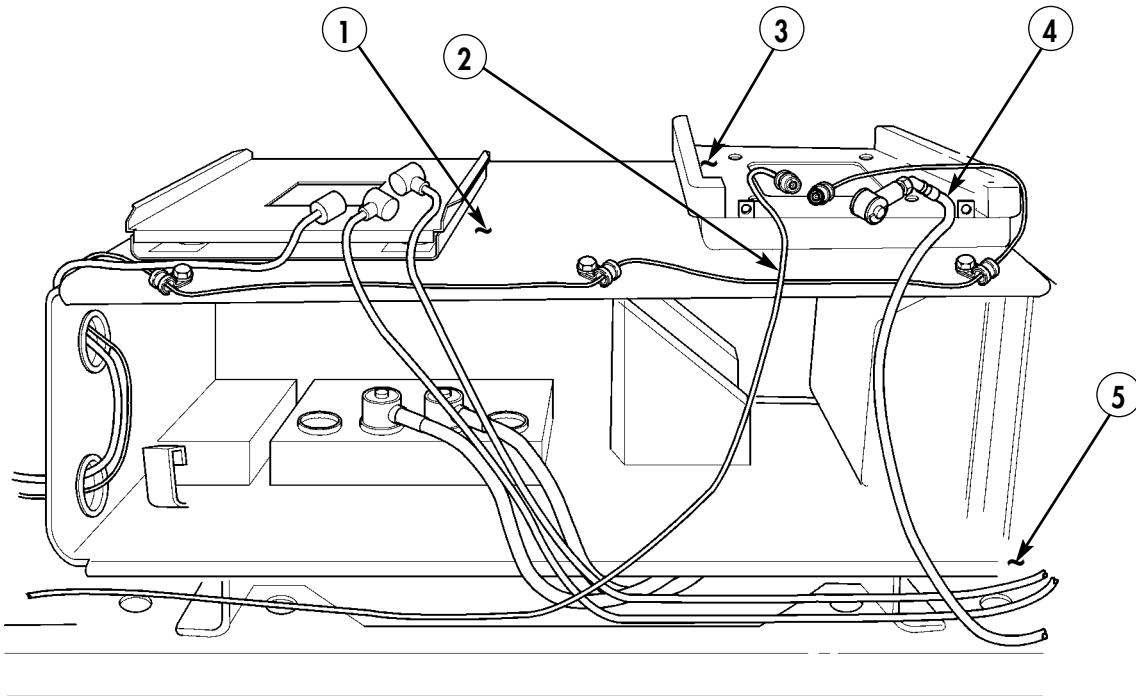

Figure 5-92.

Section XXXI. C4ISR POWER CABLES INSTALLATION

31-1. Locate, mark, and drill one 0.125-in. diameter hole (2) in rear battery box (1).

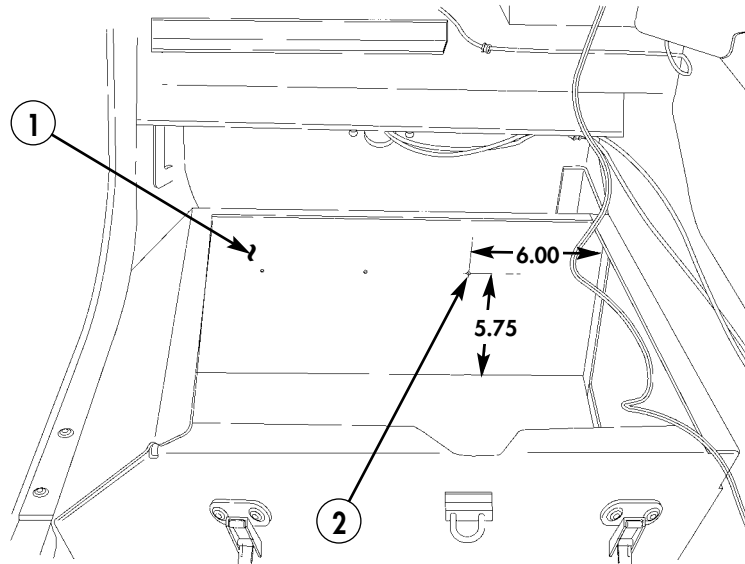
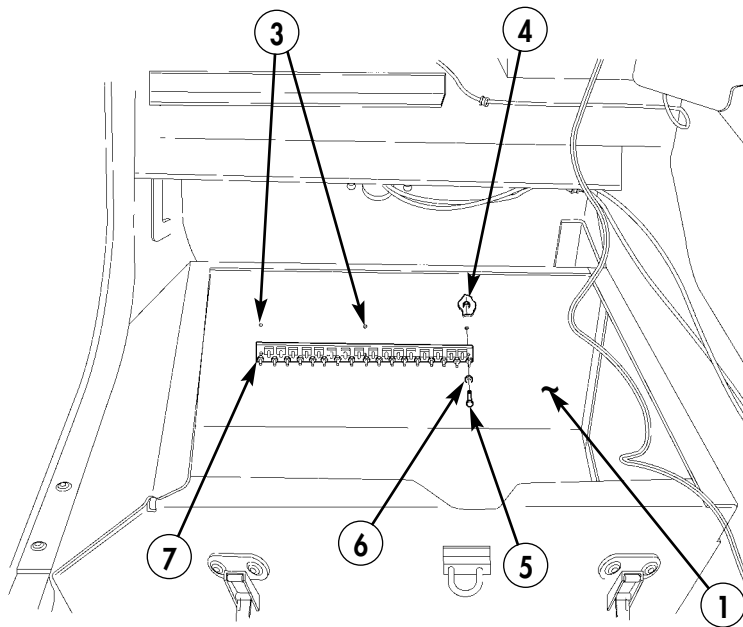

Figure 5-93.

31-2. Using terminal block as template, locate, mark, and drill two 0.125-in. diameter holes (3) in rear battery box (1).

31-3. Install terminal block (7) in battery box (1) with three screws (5), washers (6), and locknuts (4).



- 4. LOCKNUT (4-40) – MS21044-NO4 – QTY. 3**
- 5. SCREW – MS35206-217 – QTY. 3**
- 6. WASHER – MS27183-4 – QTY. 3**
- 7. TERMINAL BLOCK – MS27212-1-23 – QTY. 1**

Figure 5-94.

- 31-4. Locate, mark, and drill one 0.188-in. diameter hole (9) in battery box (1).
- 31-5. Using shunt as template, locate, mark, and drill one 0.188-in. diameter hole (8) in battery box (1).

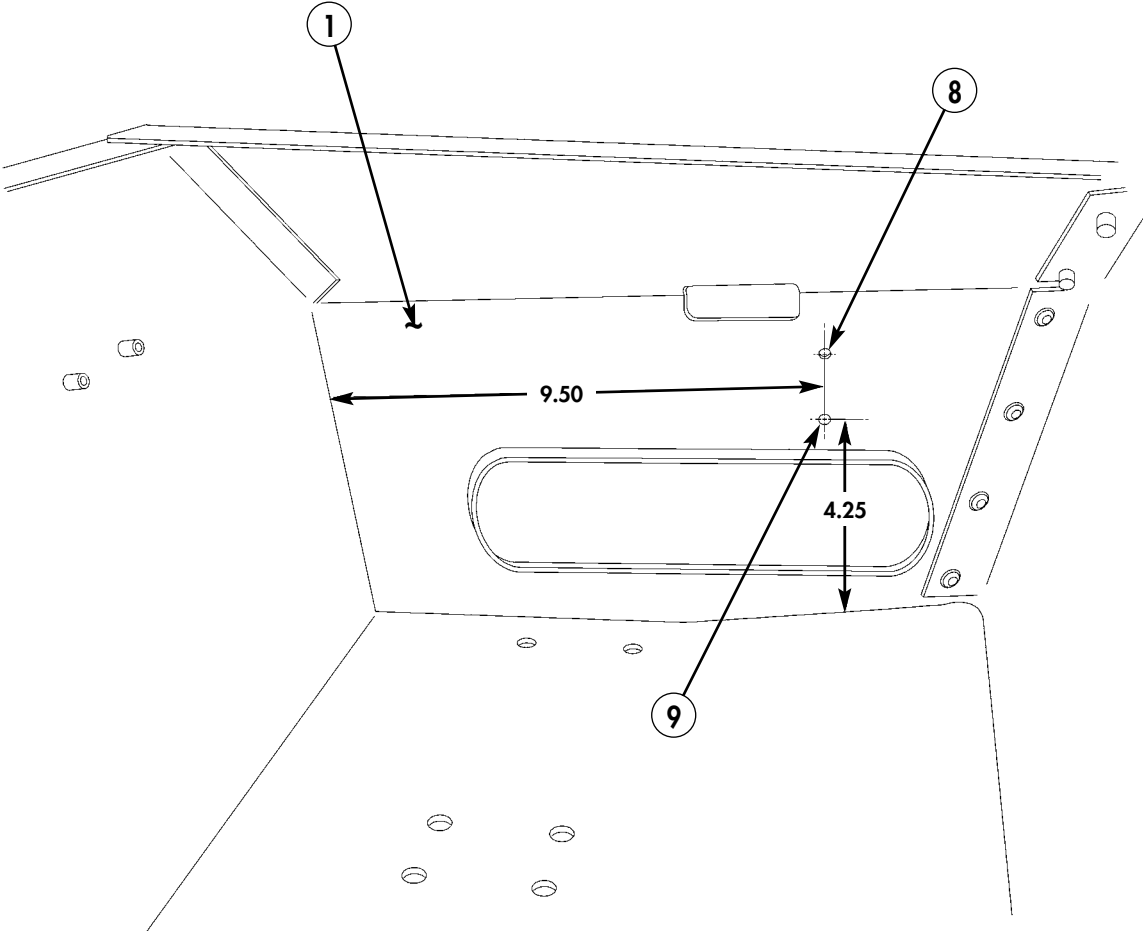
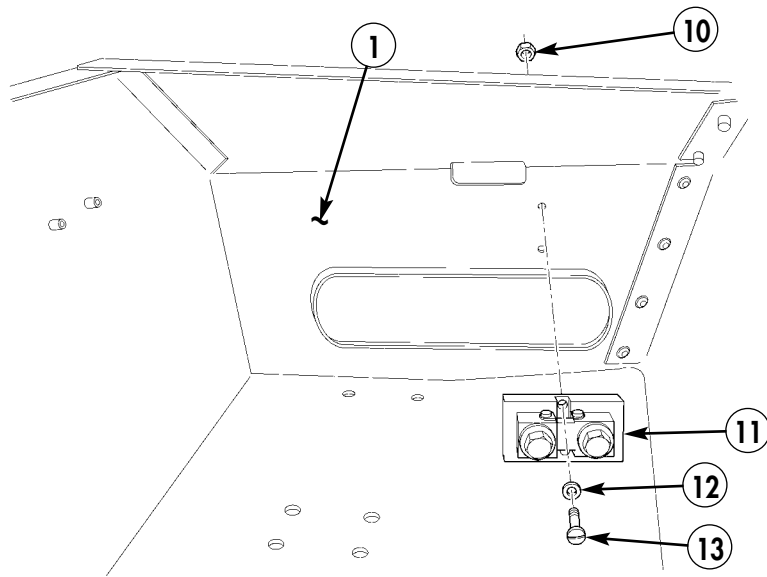

Figure 5-95.

31-6. Install shunt (11) in battery box (1) with two screws (13), washers (12), and locknuts (10).



- 10. LOCKNUT – MS21044-NO8 – QTY. 2
- 11. SHUNT – PKMM 000-013 – QTY. 1
- 12. WASHER – MS27183-41 – QTY. 2
- 13. SCREW – MS35206-247 – QTY. 2

Figure 5-96.

31-7. Locate, mark, and drill one 0.281-in. diameter hole (14) in battery box (1).

31-8. Using solenoid as template, locate, mark, and drill one 0.281-in. diameter hole (15) in battery box (1).

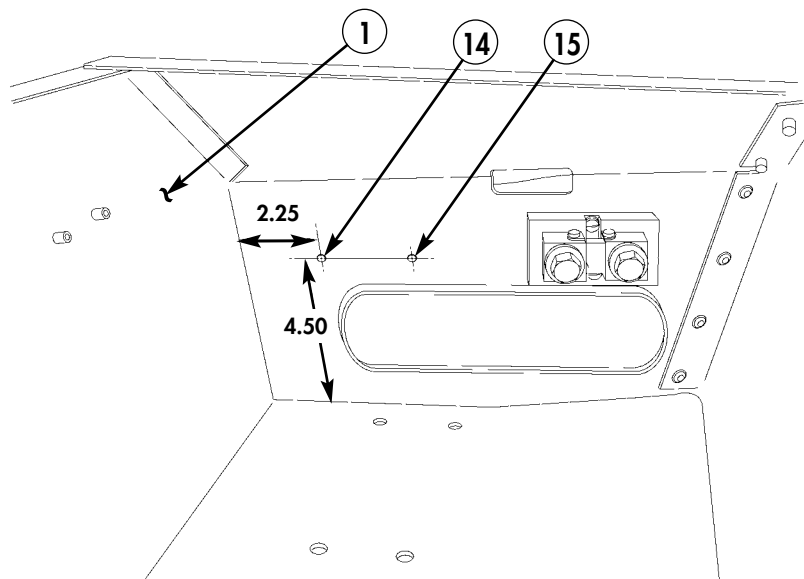
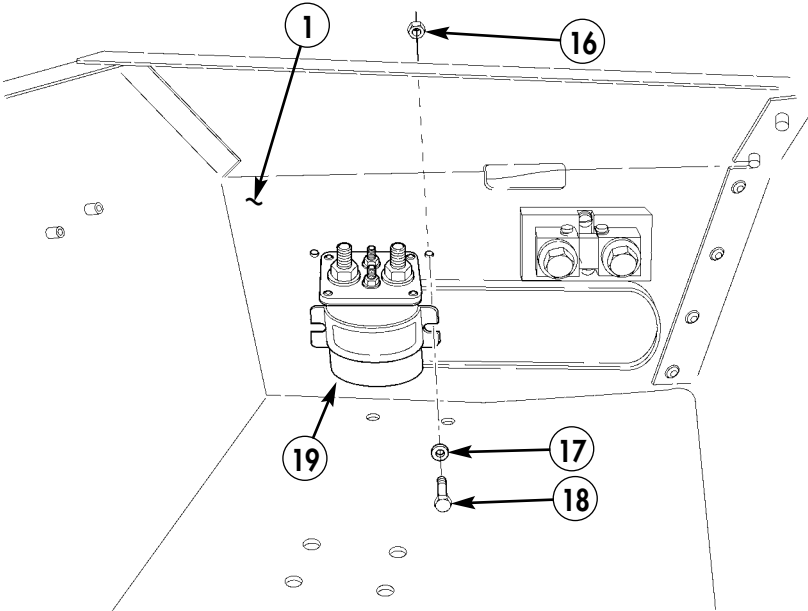

Figure 5-97.

31-9. Install solenoid (19) in battery box (1) with two capscrews (18), washers (17), and locknuts (16).



- 16. LOCKNUT - MS17829-4C - QTY. 2
- 17. WASHER - 2436161 - QTY. 2
- 18. CAPSCREW - B1821BH025C075N - QTY. 2
- 19. SOLENOID - 586-905 - QTY. 1

Figure 5-98.

- 31-10. Drill one 2.50-in. diameter hole (21) in battery box (1).
- 31-11. Cut grommet material (20) to length and install in hole (21) of battery box (1).

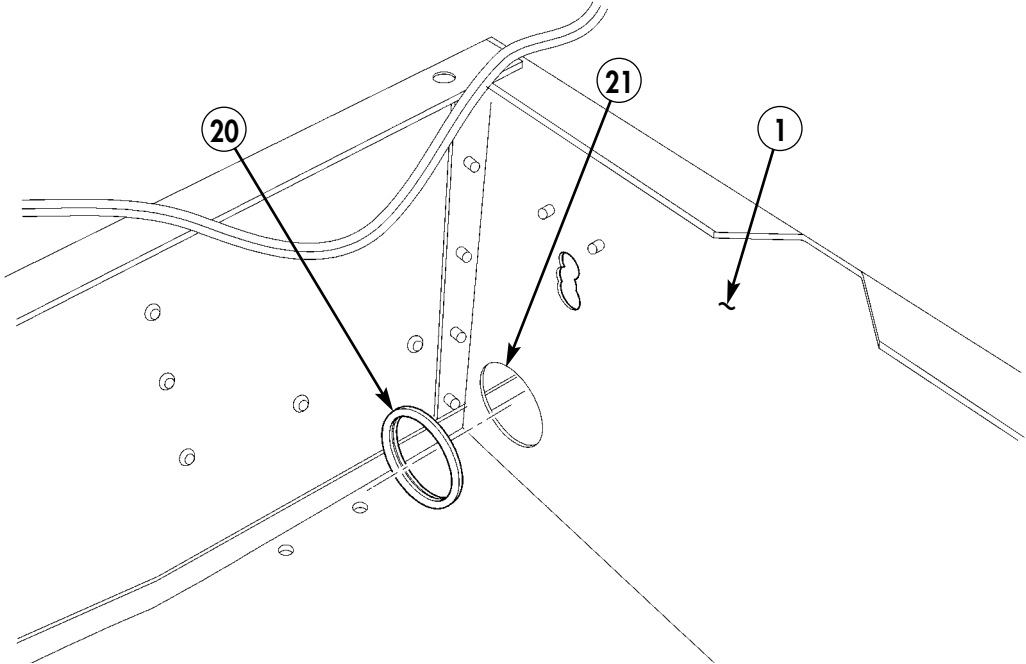

- 20. GROMMET MATERIAL - 12341628 - QTY. A/R

Figure 5-99.

31-12. Locate, mark, and drill one 1.25-in. diameter hole (22) in battery box (1).

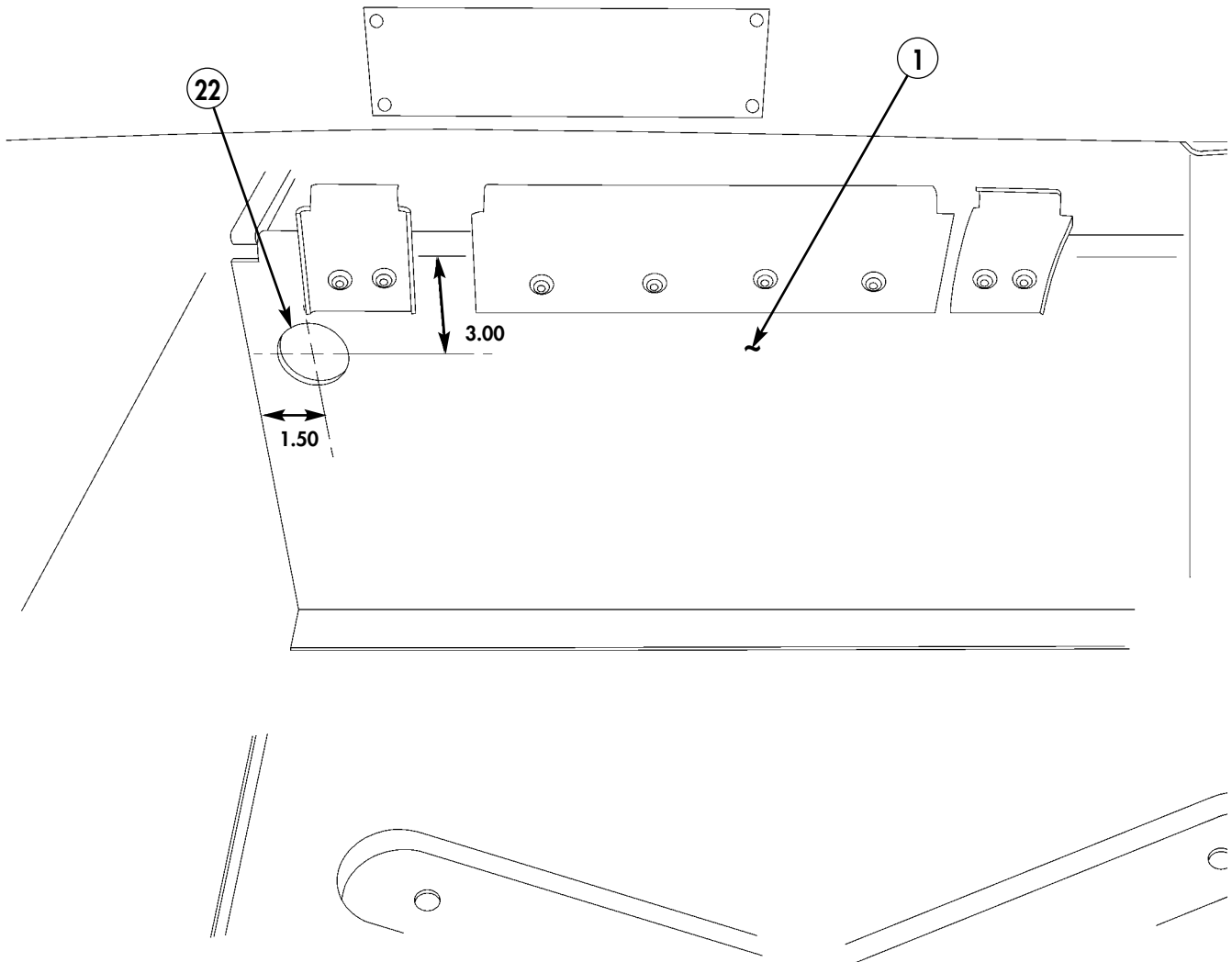
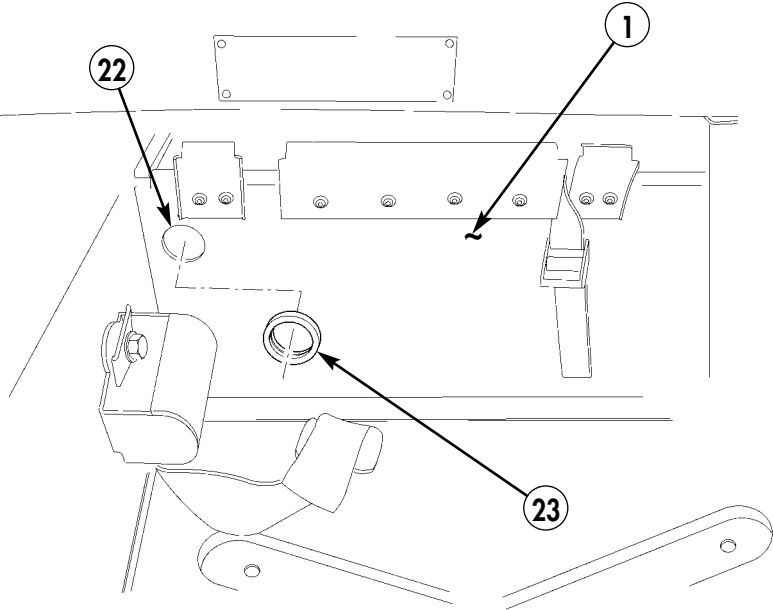

Figure 5-100.

31-13. Cut grommet material (23) to length and install in hole (22) of battery box (1).



23. GROMMET - 12341628 - QTY. A/R

Figure 5-101.

31-14. Locate, mark, and drill two 0.359-in. diameter holes (24) in bottom of battery box (1).

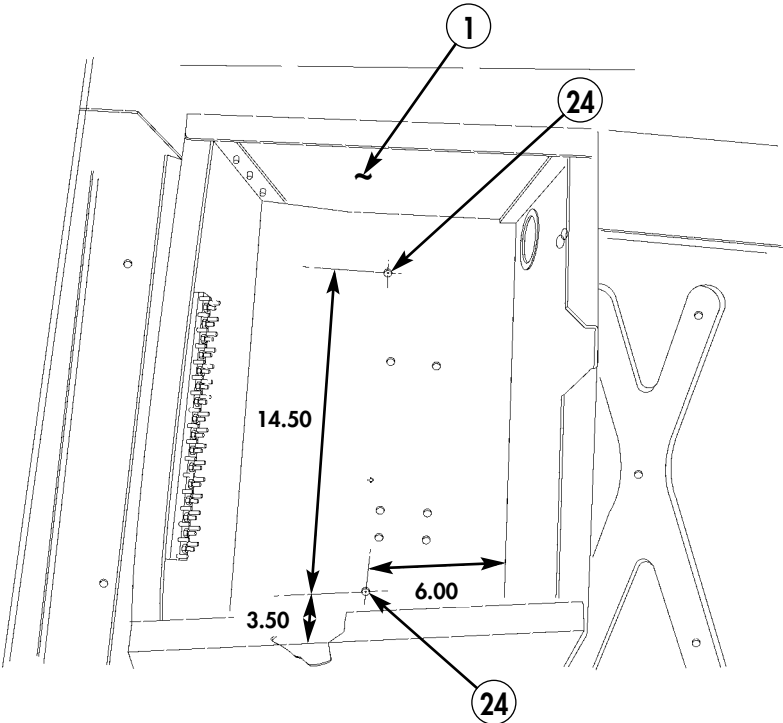

Figure 5-102.

31-15. Locate, mark, and drill nine 0.188-in. diameter holes (25) in battery box (1).

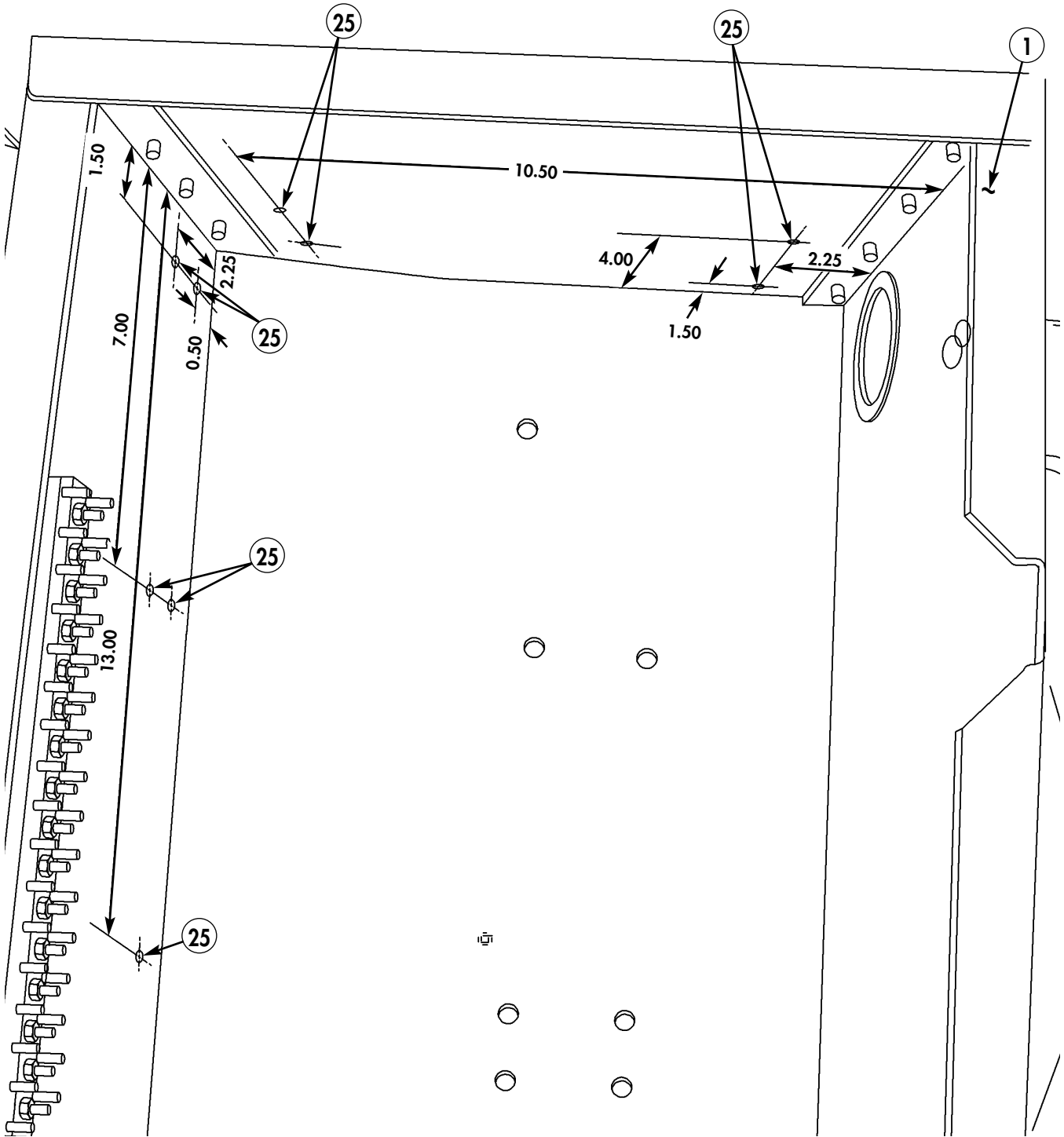
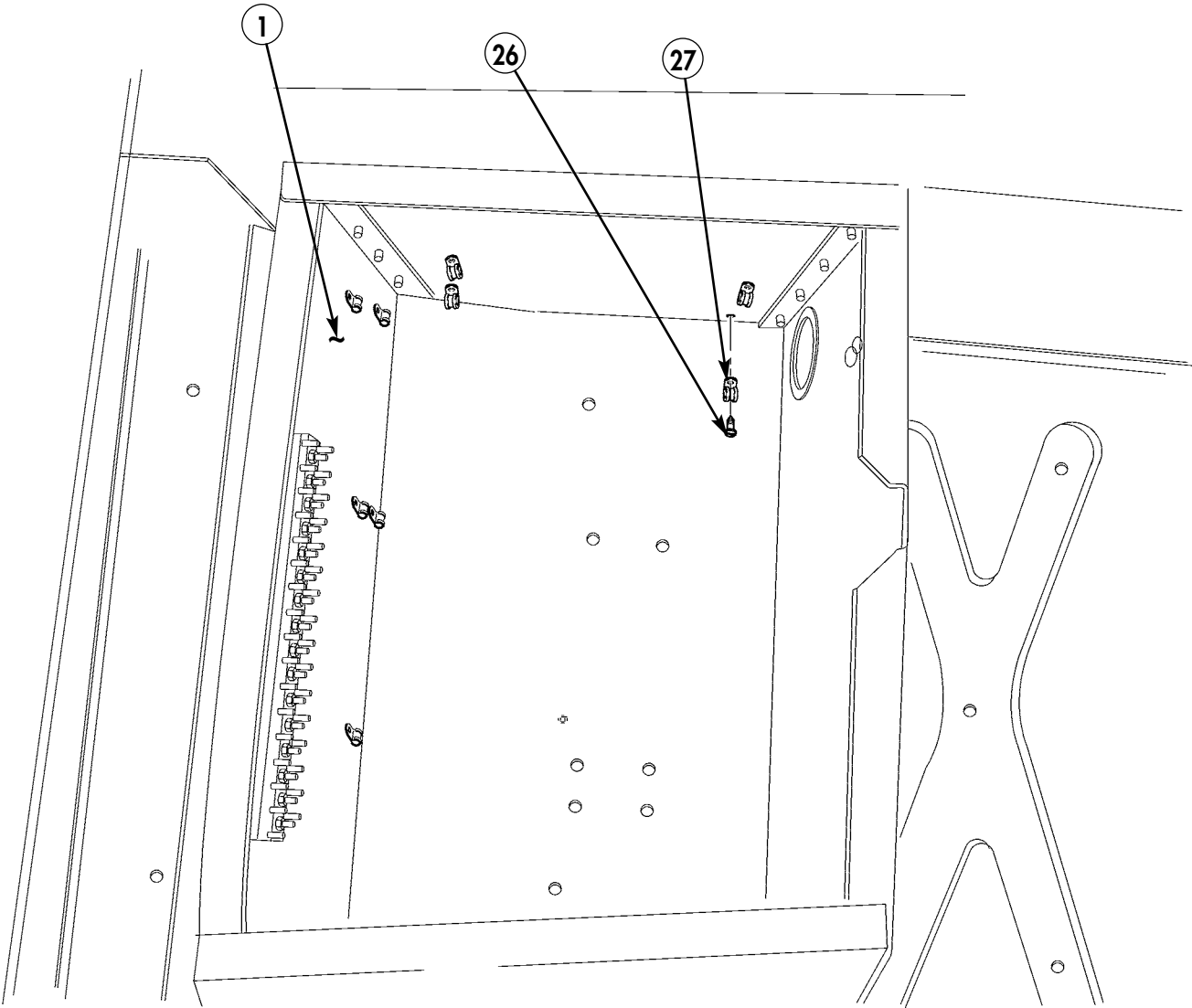

Figure 5-103.

31-16. Install nine clamps (27) in battery box (1) with self-tapping screws (26).



- 26. SELF-TAPPING SCREW – 9421073 – QTY. 9
- 27. LOOP CLAMP – MS21333-65 – QTY. 9

Figure 5-104.

31-17. Locate, mark, and drill two 0.188-in. diameter holes (29) on top of tunnel (28).

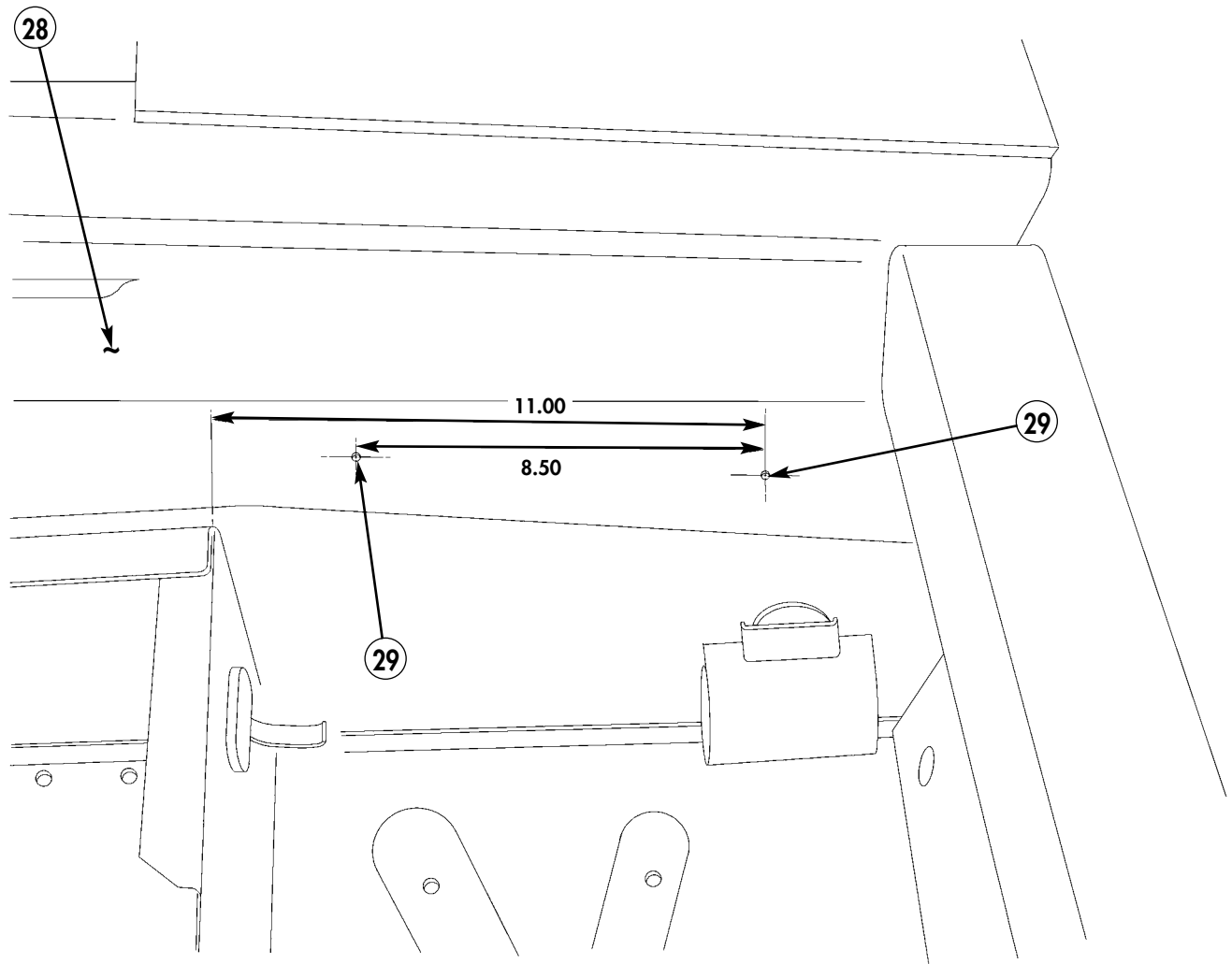

Figure 5-105.

31-18. Locate, mark, and drill two 0.188-in. diameter holes (30) in side of tunnel (28).

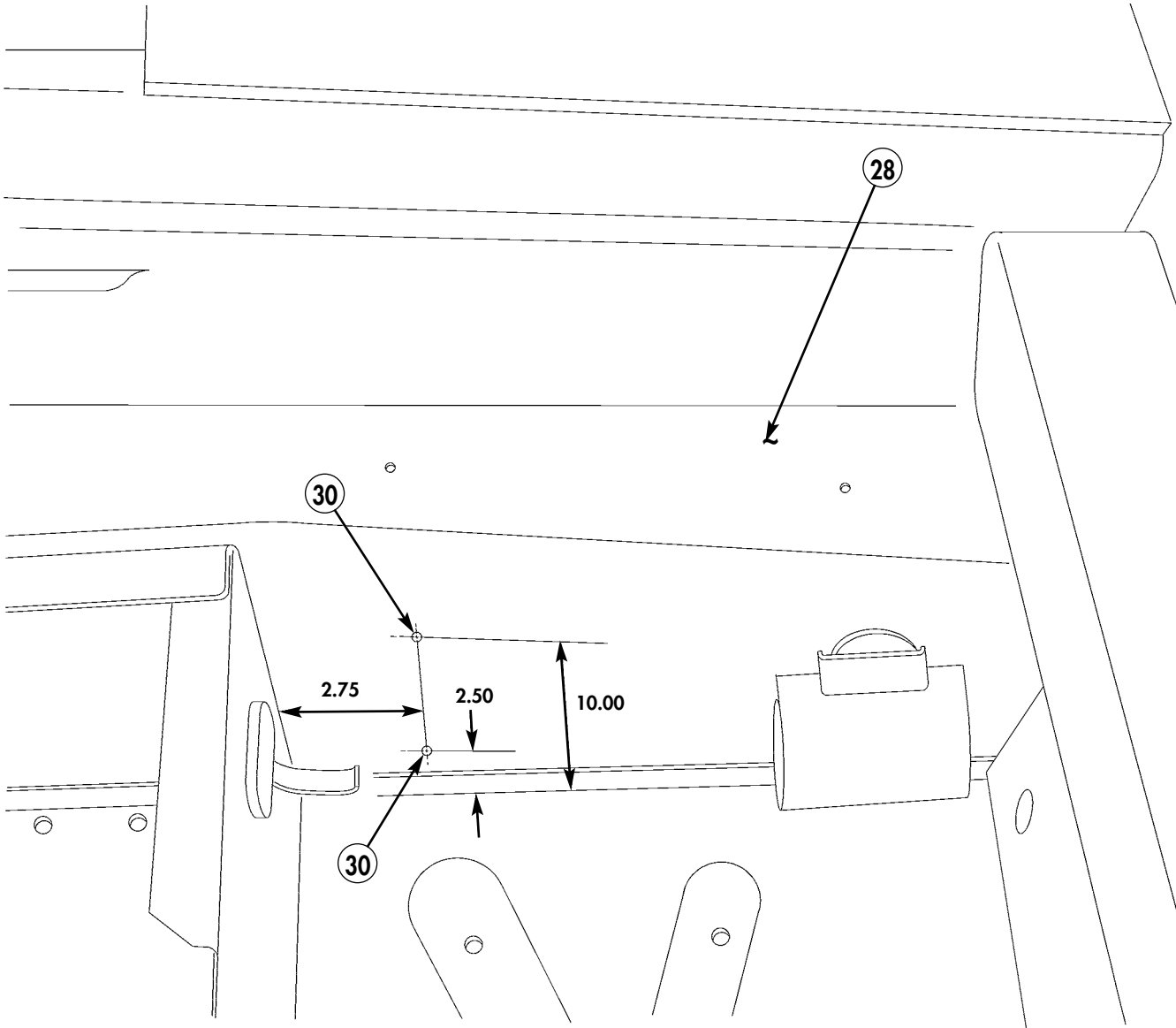
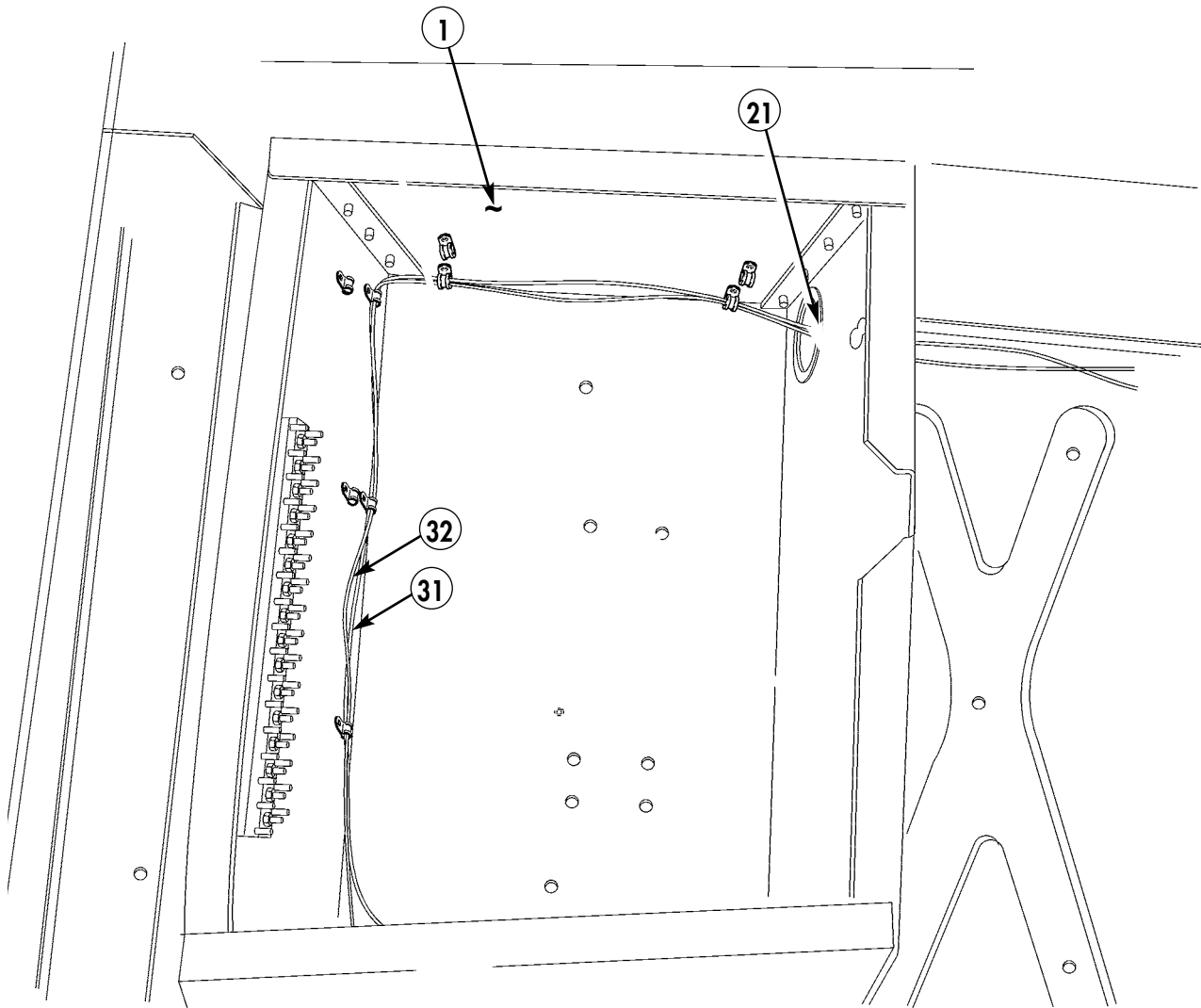

Figure 5-106.

NOTE

Do not connect cables to solenoid and shunt at this time.

31-19. Route cables (31) and (32) from solenoid and shunt through battery box (1) and hole (21).



31. CABLE (BATTERY TO SOLENOID) – RCSK-19637 – QTY. 1

32. CABLE (BATTERY TO SHUNT) – RCSK-19638 – QTY. 1

Figure 5-107.

31-20. Route cables (31) and (32) along tunnel (28), through hole (35) in front battery box (36), and secure with clamps (33) and self-tapping screws (34).

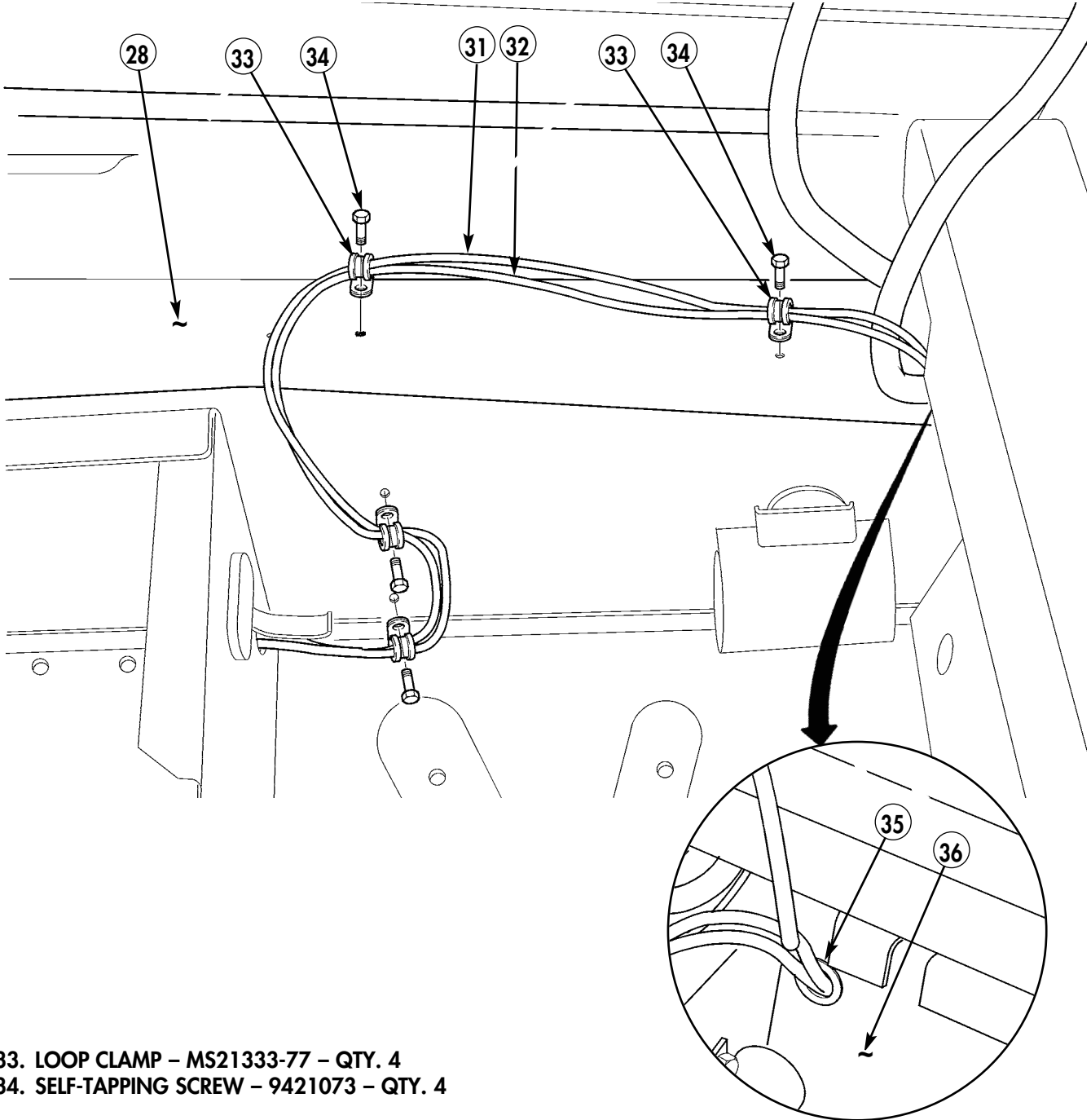

- 33. LOOP CLAMP – MS21333-77 – QTY. 4
- 34. SELF-TAPPING SCREW – 9421073 – QTY. 4

Figure 5-108.

31-21. Connect control cables (38) and (40) to charge control box (37).

31-22. Route small control cable (40) between speakers (41) on lower shelf of multi-net rack (39).

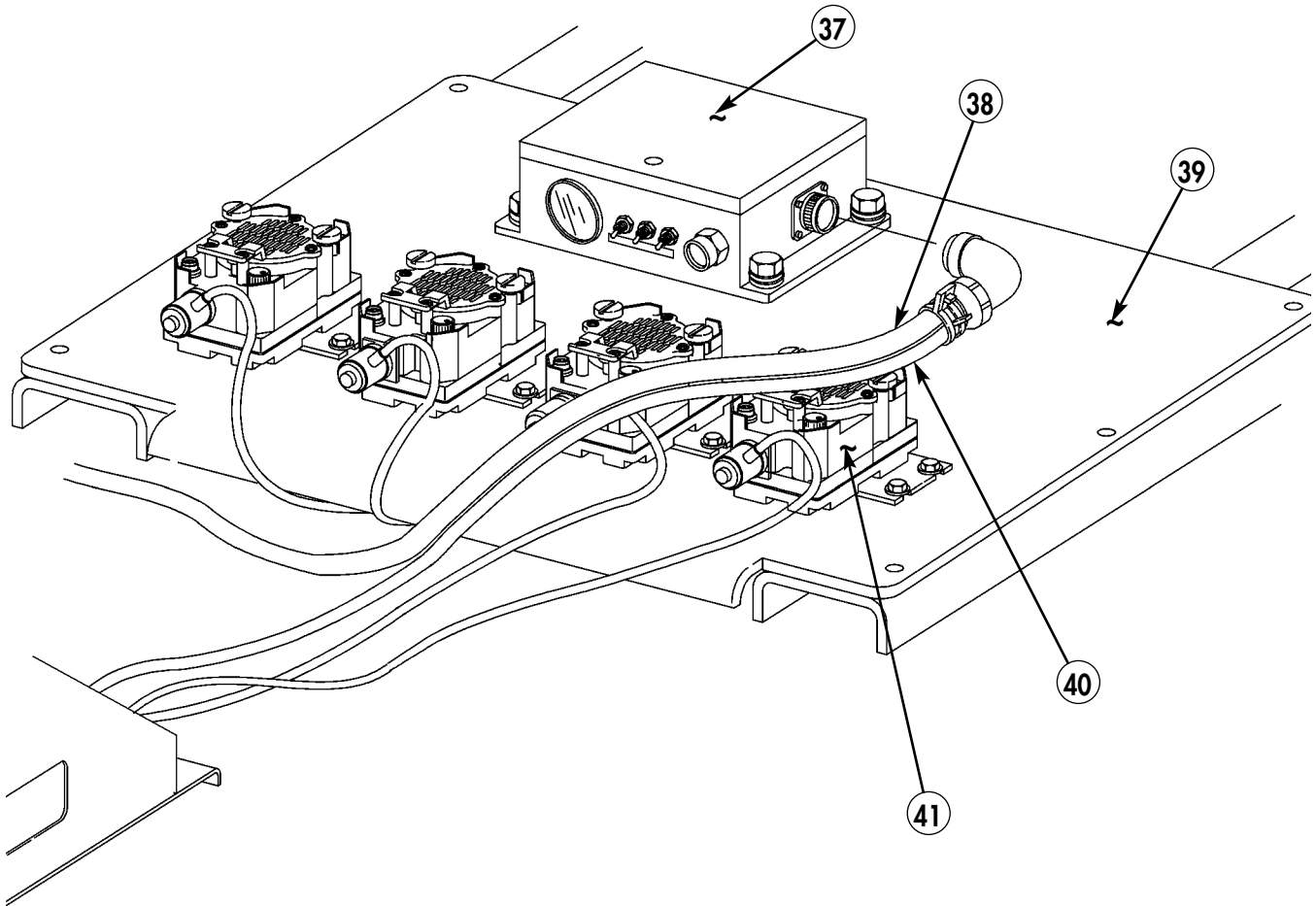

40. CONTROL CABLE (SMALL) – PKMM 0004 – QTY. 1

Figure 5-109.

- 31-23. Route small control cable (40) from left-side insulation (45) up firewall (46).
- 31-24. Secure small control cable (40) with two clamps (44) and self-tapping screws (43).
- 31-25. Route small control cable (40) under dash panel (42).

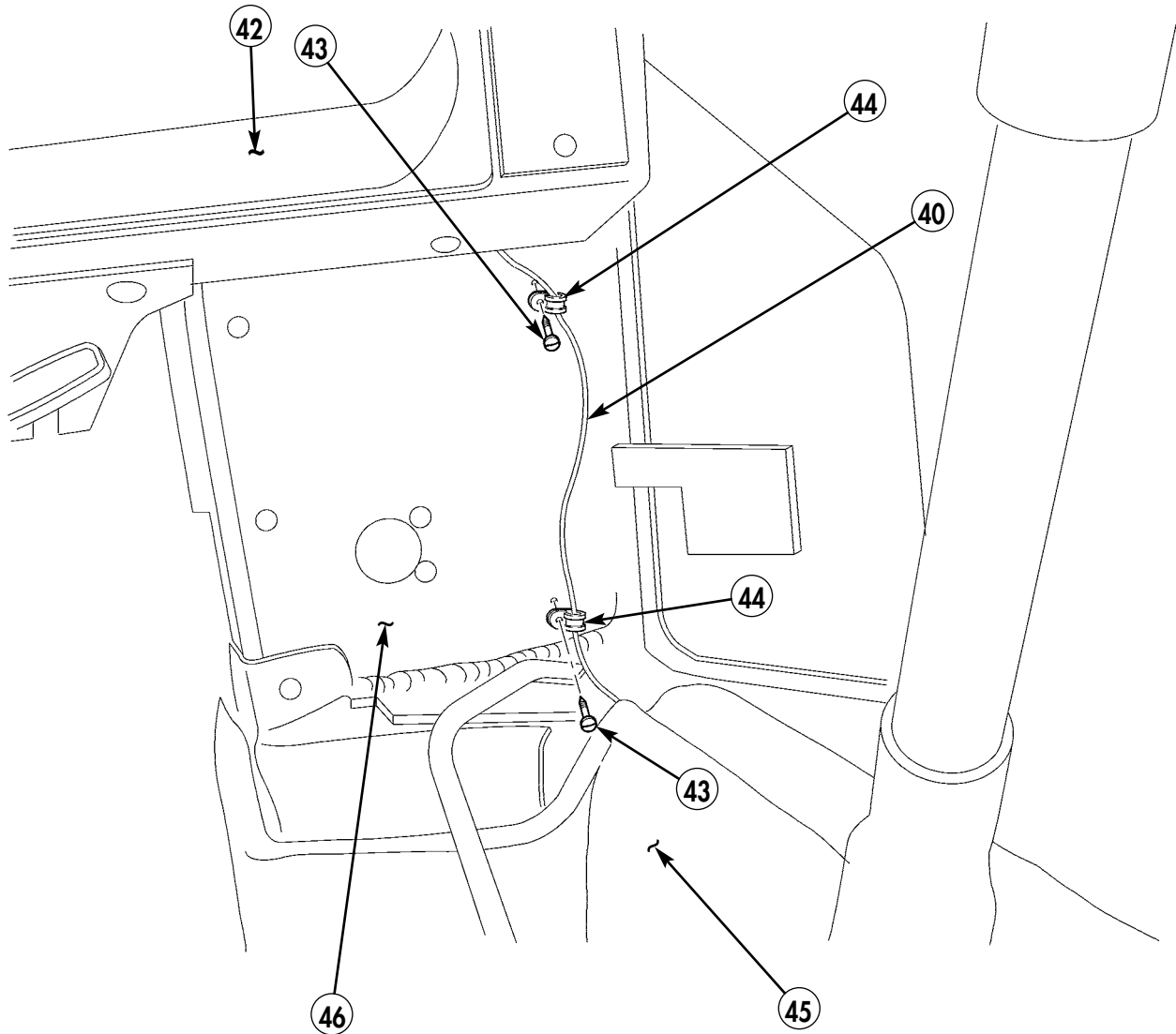

- 43. SELF-TAPPING SCREW – 9421073 – QTY. 2
- 44. LOOP CLAMP – MS21333-71 – QTY. 2

Figure 5-110.

31-26. Disconnect light switch (48) from harness (49).

31-27. Remove four bolts (47) and light switch (48) from dash panel (42).

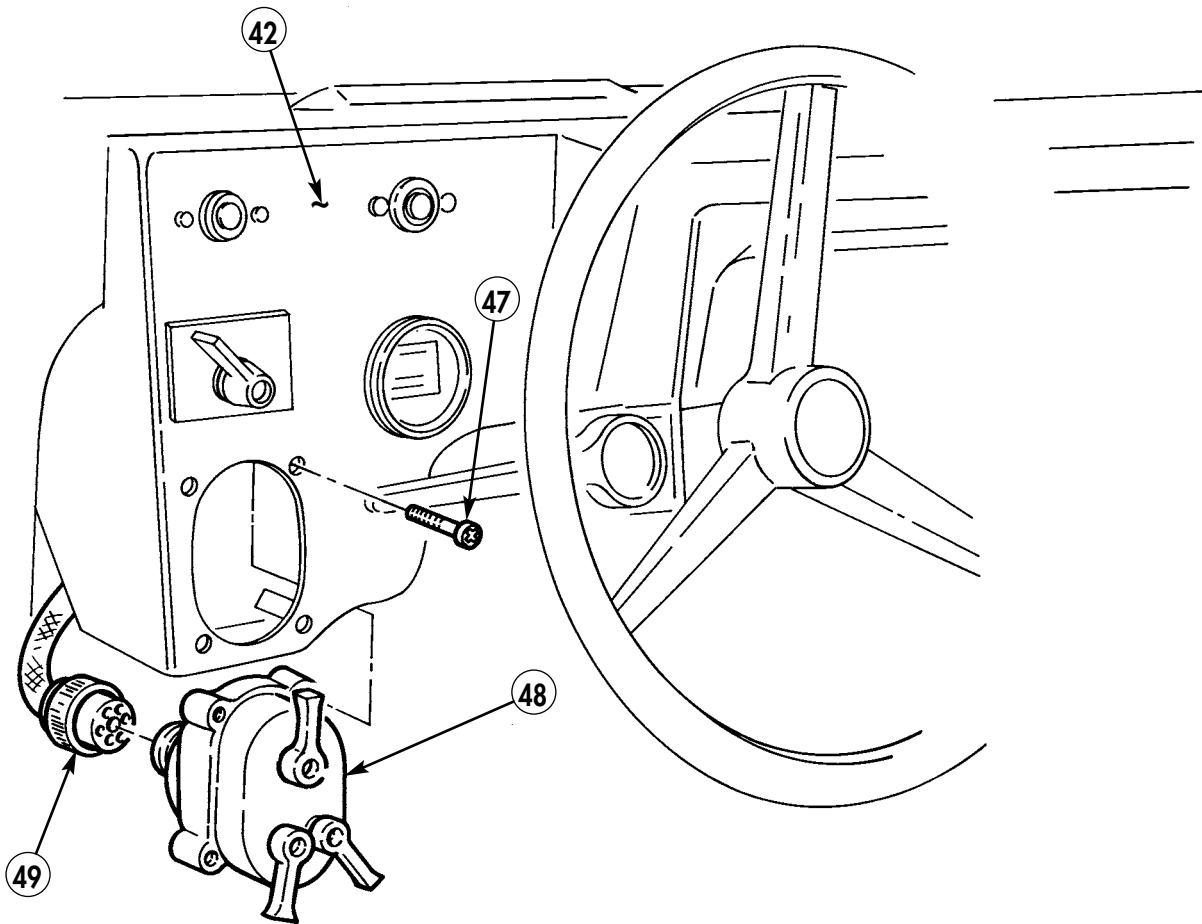

Figure 5-111.

- 31-28. Strip wire insulation from wire 29A (50).
- 31-29. Splice small control cable (40) with wire 29A (50).
- 31-30. Cover splice with electrical tape (51).

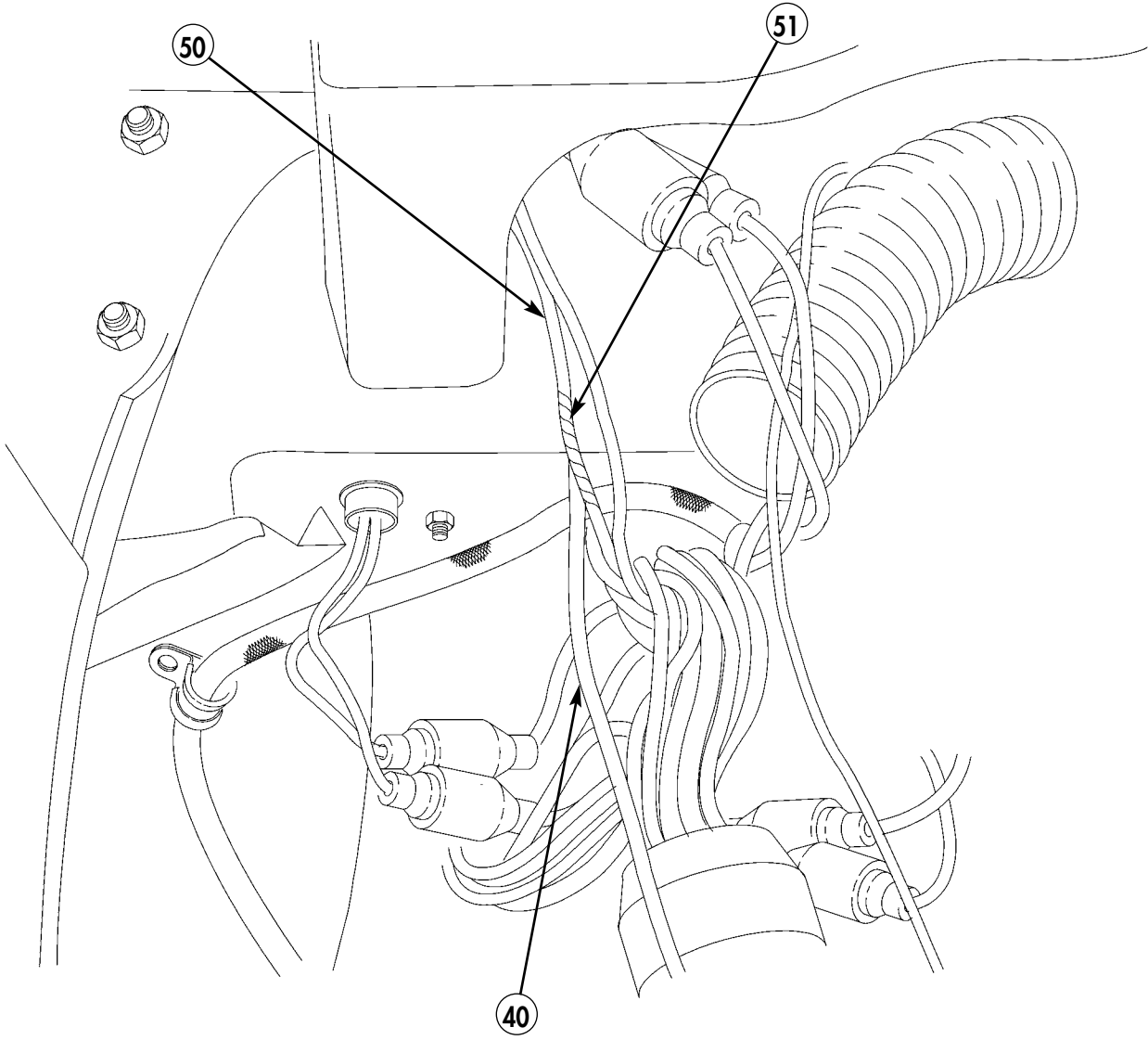

Figure 5-112.

31-31. Connect light switch (48) to harness (49).

31-32. Install light switch (47) in dash panel (42) with four bolts (47).

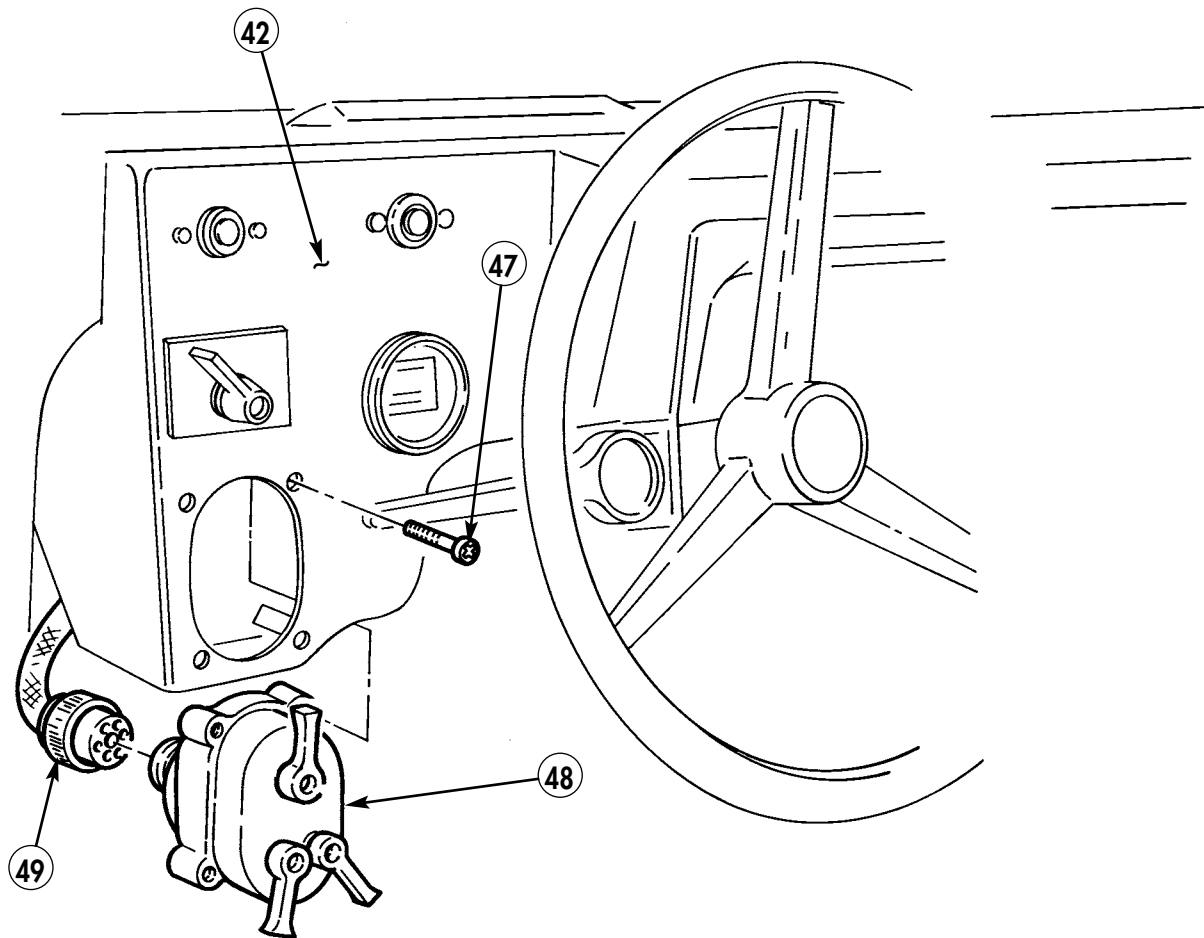
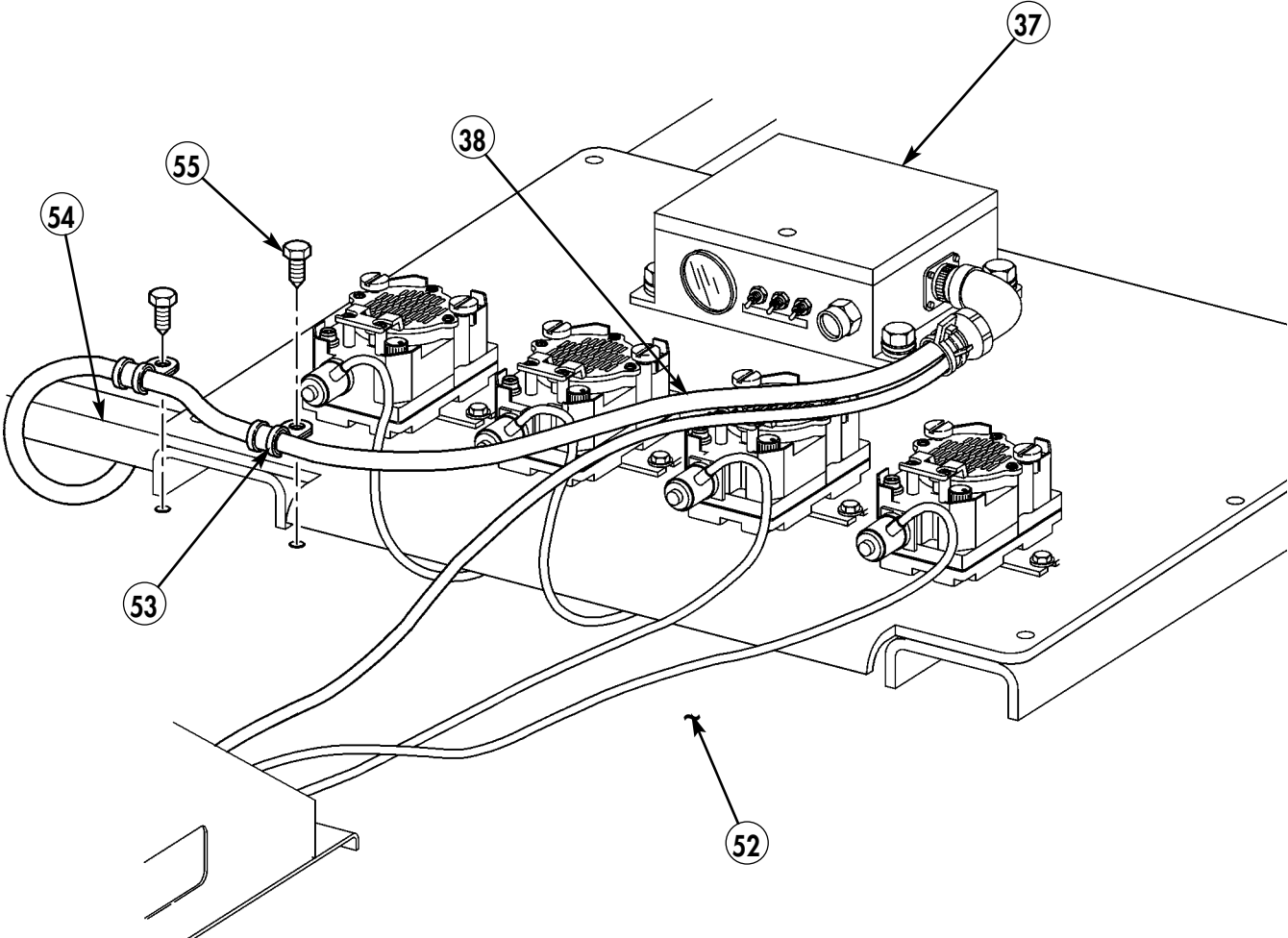

Figure 5-113.

- 31-33. Route large control cable (38) from charge control box (37), along cargo floor (52), and under B-beam (54).
- 31-34. Secure large control cable (38) to cargo floor (52) with four clamps (53) and screws (55).



38. CONTROL CABLE (LARGE) – PKMM 0004 – QTY. 1

Figure 5-114.

31-35. Route SINCGARS power cable (57) to MT-6353/VRC mounting base (56).

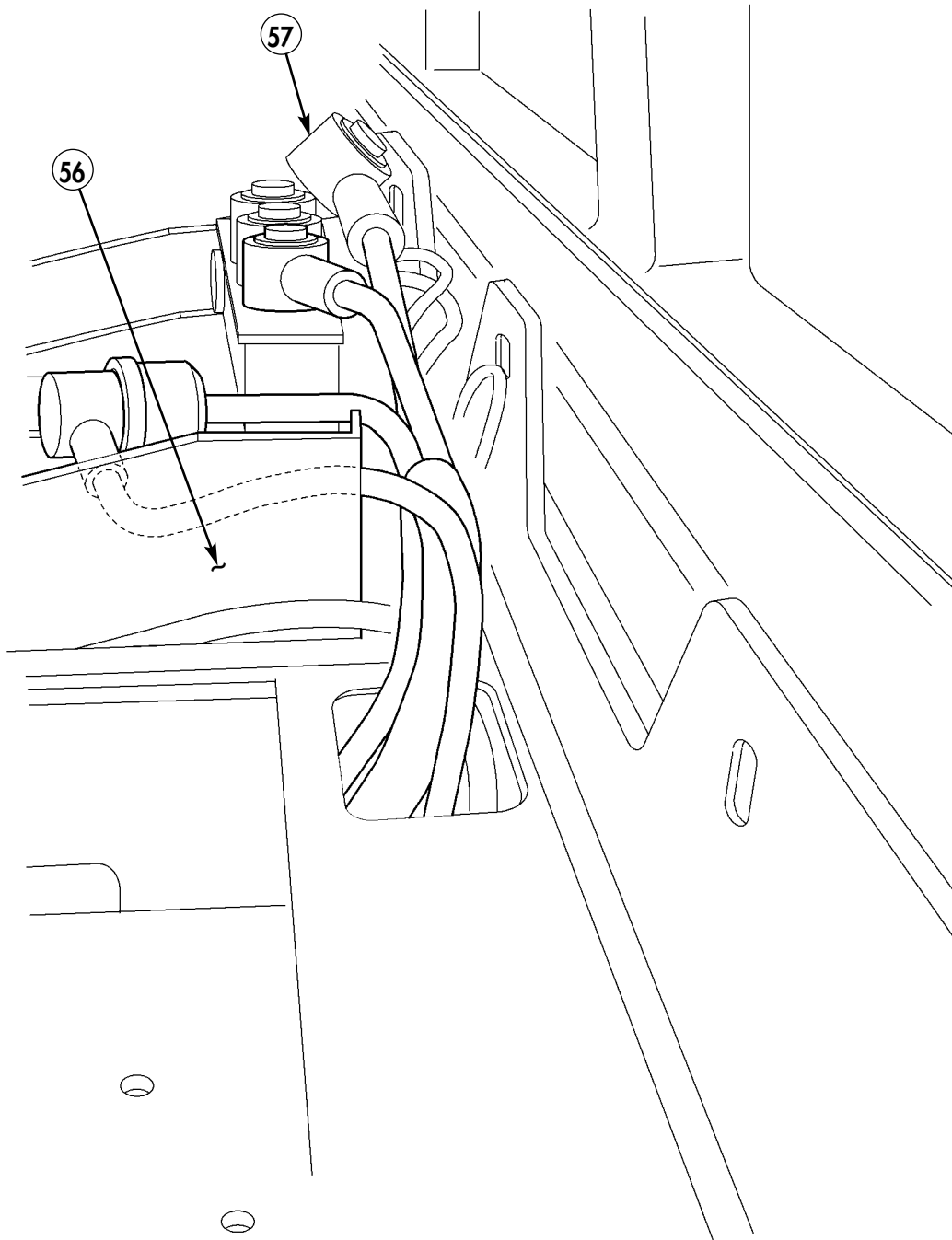

57. SINCGARS POWER CABLE – A3014039-7 – QTY. 1

Figure 5-115.

- 31-36.** Route NTDR power cable (64) and lower SINCGARS power cable (65) from battery box (1) through hole (63) in frame (62).
- 31-37.** Route EPLRS power cable (58) and upper SINCGARS power cable (59) over frame and behind multi-net rack (66). Secure cables (58) and (59) with loop clamp (60) and self-tapping screw (61).

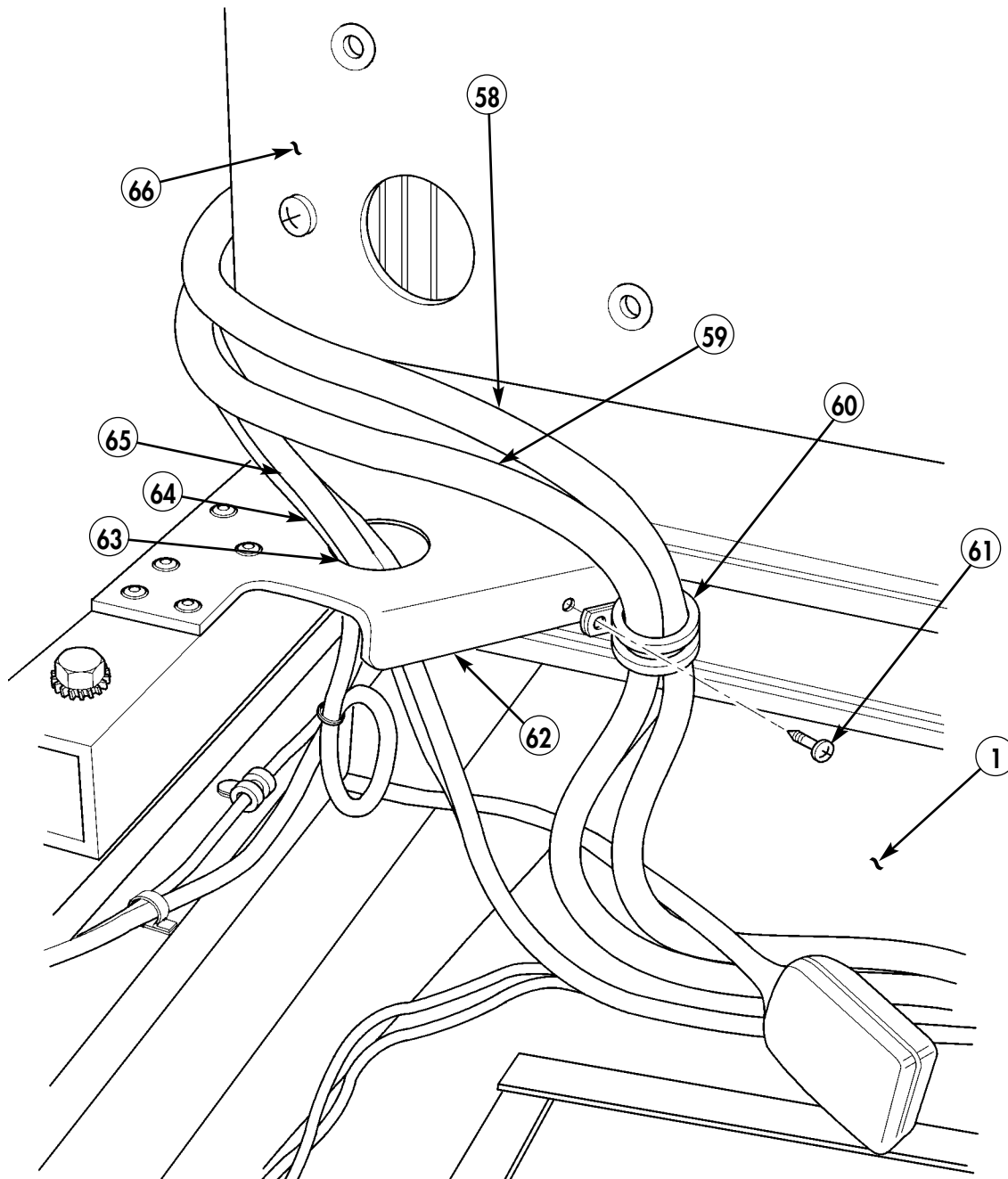
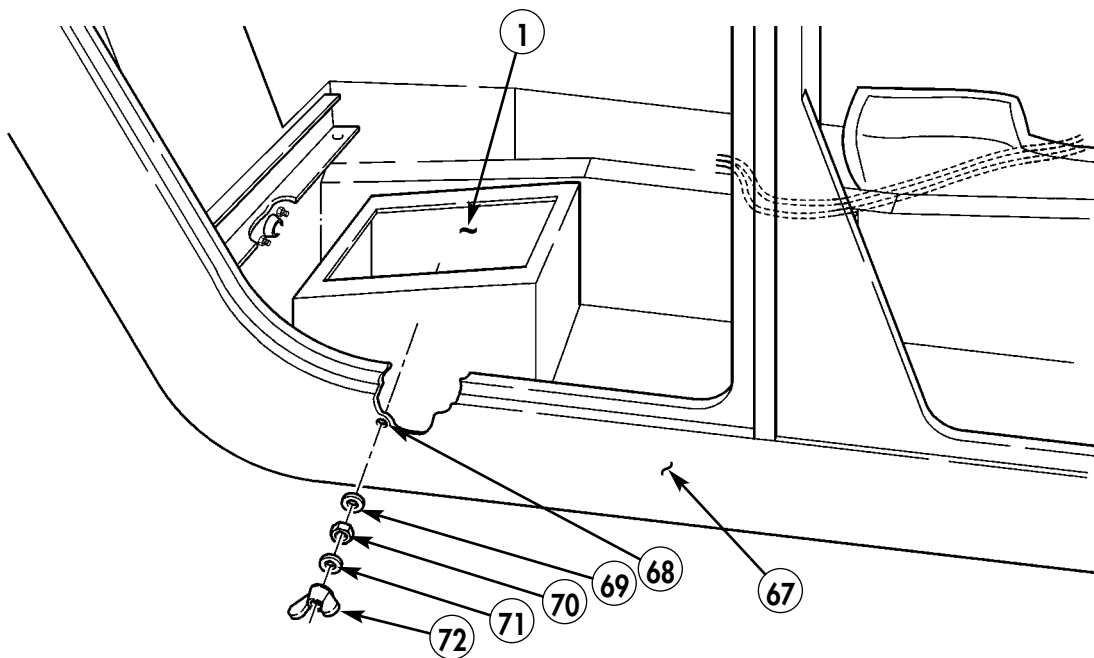

Figure 5-116.

- 58.** EPLRS POWER CABLE - A3004939 - QTY. 1
59. UPPER SINCGARS POWER CABLE - A3014039-2 - QTY. 1
60. LOOP CLAMP - MS21333-75 - QTY. 1
61. SELF-TAPPING SCREW - 9421073 - QTY. 1
64. POWER CABLE (NTDR) - 8174912-2 - QTY. 1
65. LOWER SINCGARS POWER CABLE - A3014039-2 - QTY. 1

- 31-38. Locate, mark, and drill one 0.390-in. diameter hole (68) in body (67) of vehicle and battery box (1).
- 31-39. Install shunt ground cable (80) on body (67) with screw (79), lockwasher (69), nut (70), washer (71), and wingnut (72).
- 31-40. Route ground cable (80) to shunt (11).
- 31-41. Route cable (78) from shunt (11) to rear battery. Secure cables (78) and (80) with screw (79).
- 31-42. Route cable (81) from shunt (11) to terminal block. Secure cables (81) and (32) with screw (82).
- 31-43. Route cable (83) from solenoid (19) to negative terminal.
- 31-44. Route cable (77) from solenoid (19) to rear battery. Secure cables (77) and (83) with nut (76).
- 31-45. Secure cable (31) to solenoid (19) with washer (73) and nut (74).
- 31-46. Route cable (84) from solenoid (19) to negative terminal.
- 31-47. Secure cable (84) to solenoid with nut (75).



- 69. LOCKWASHER - MS35338-46 - QTY. 1
- 70. NUT - MS51967-9 - QTY. 1
- 71. WASHER - 11500256 - QTY. 1
- 72. WINGNUT - MS35425-75 - QTY. 1

Figure 5-117.

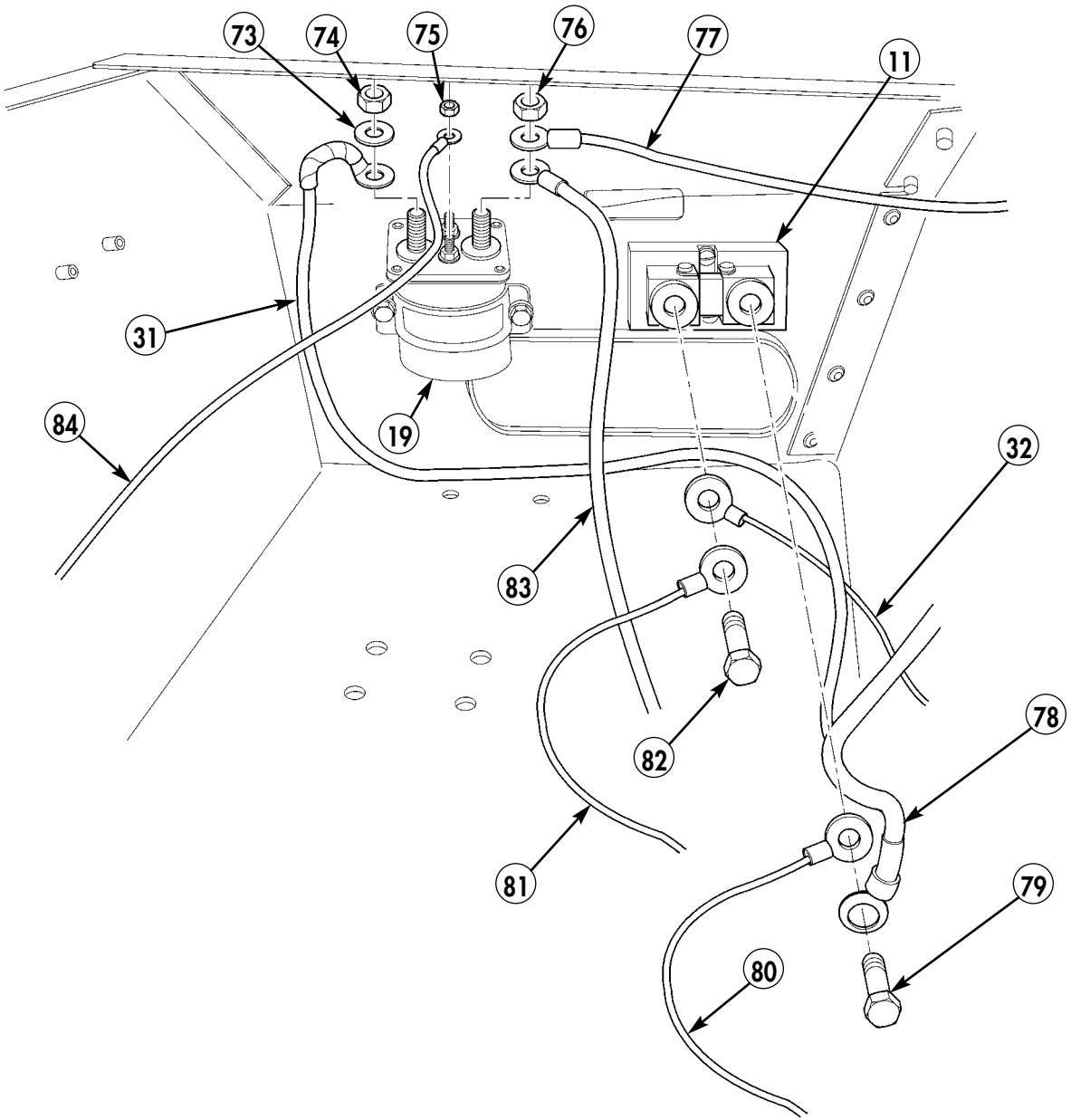
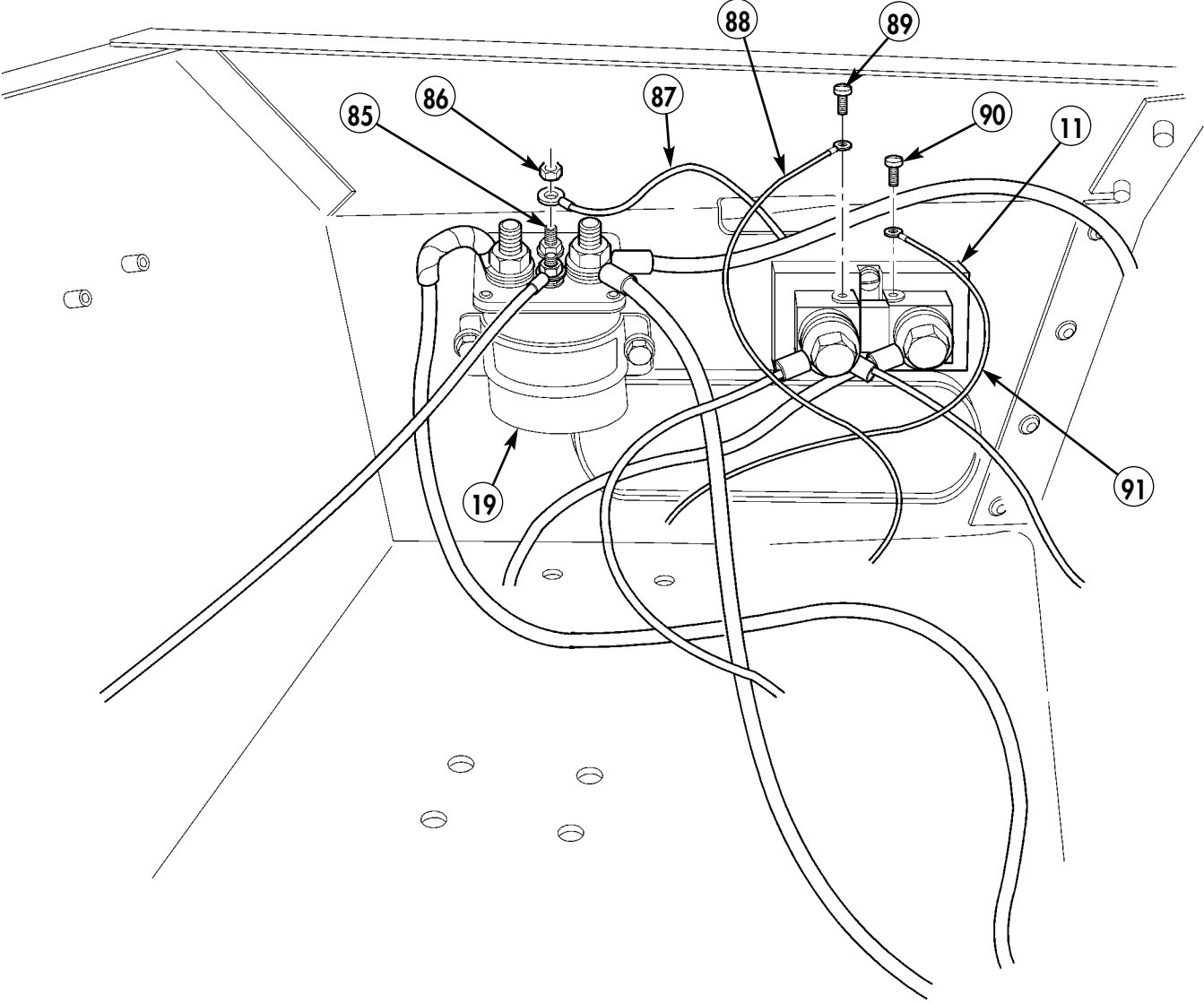

Figure 5-118.

TB 9-2320-280-35-10

- 31-48.** Route red cable (87) from stud (85) of solenoid (19) to control box. Secure cable (87) to solenoid (19) with nut (86).
- 31-49.** Route green cable (88) from shunt (11) to control box. Secure green cable (88) to shunt (11) with screw (89).
- 31-50.** Route orange cable (91) from shunt (11) to control box. Secure orange cable (91) to shunt (11) with screw (90).



- 87. CABLE (CONTROL BOX, RED) – N/A – QTY.1
- 88. CABLE (CONTROL BOX, GREEN) – N/A – QTY.1
- 91. CABLE (CONTROL BOX, ORANGE) – N/A – QTY.1

Figure 5-119.

- 31-51. Attach shrink tubing (109) and terminal lug (107) to EPLRS positive power terminal (124). Secure to terminal board stud (92) with existing nut (108).
- 31-52. Attach shrink tubing (109) and terminal lug (107) to EPLRS negative power terminal (115). Secure to terminal board stud (101) with existing nut (108).
- 31-53. Attach shrink tubing (109) and terminal lug (107) to lower SINGGARS positive power terminal (123). Secure to terminal board stud (93) with existing nut (108).
- 31-54. Attach shrink tubing (109) and terminal lug (107) to lower SINGGARS negative power terminal (114). Secure to terminal board stud (102) with existing nut (108).
- 31-55. Attach shrink tubing (109) and terminal lug (107) to front SINGGARS positive power terminal (122). Secure to terminal board stud (94) with existing nut (108).
- 31-56. Attach shrink tubing (109) and terminal lug (107) to front SINGGARS negative power terminal (113). Secure to terminal board stud (103) with existing nut (108).
- 31-57. Attach shrink tubing (109) and terminal lug (107) to PLGR positive power terminal (121). Secure to terminal board stud (95) with existing nut (108).
- 31-58. Attach shrink tubing (109) and terminal lug (107) to PLGR negative power terminal (112). Secure to terminal board stud (104) with existing nut (108).
- 31-59. Attach shrink tubing (109) and terminal lug (107) to white control cable positive terminal (119). Secure to terminal board stud (97) with existing nut (108).
- 31-60. Attach shrink tubing (109) and terminal lug (107) to black control cable negative terminal (110). Secure to terminal board stud (106) with existing nut (108).
- 31-61. Attach shrink tubing (109) and terminal lug (107) to upper SINGGARS positive power terminal (118). Secure to terminal board stud (98) with existing nut (108).
- 31-62. Attach shrink tubing (109) and terminal lug (107) to upper SINGGARS negative power terminal (116). Secure to terminal board stud (100) with existing nut (108).
- 31-63. Attach shrink tubing (109) and terminal lug (107) to solenoid and positive power terminal (120). Secure to terminal board stud (96) with existing nut (108).
- 31-64. Attach shrink tubing (109) and terminal lug (107) to shunt to negative terminal (117). Secure to terminal board stud (99) with existing nut (108).
- 31-65. Attach shrink tubing (109) and terminal lug (107) to solenoid to negative terminal (111). Secure to terminal board stud (105) with existing nut (108).

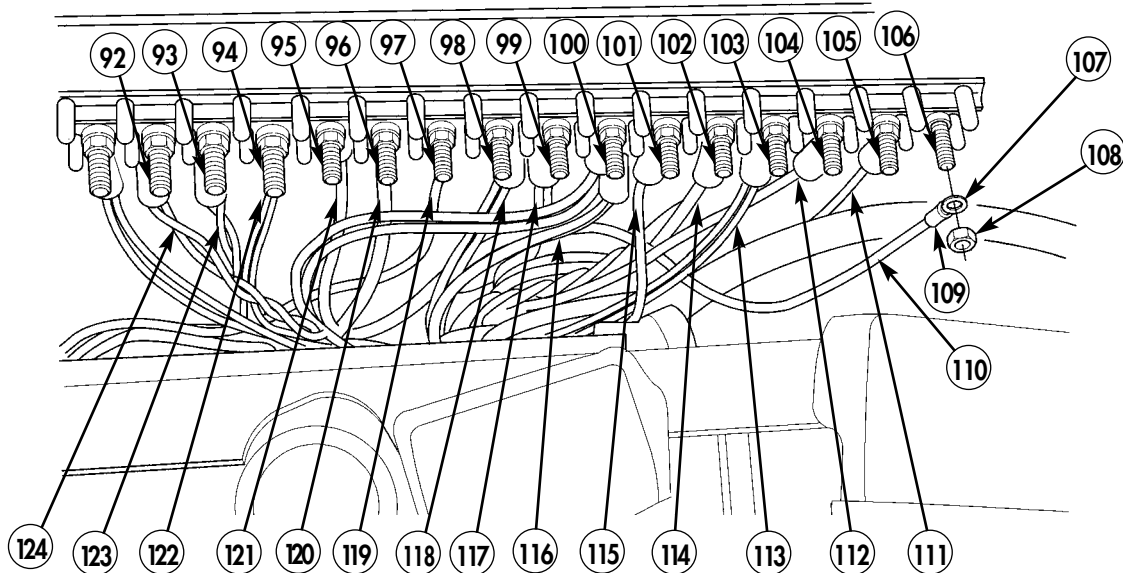

109. SHRINK TUBING – MS23053/4-302-0 – QTY. A/R

Figure 5-120.

31-66. Bundle cables and secure with tiedown straps (125).

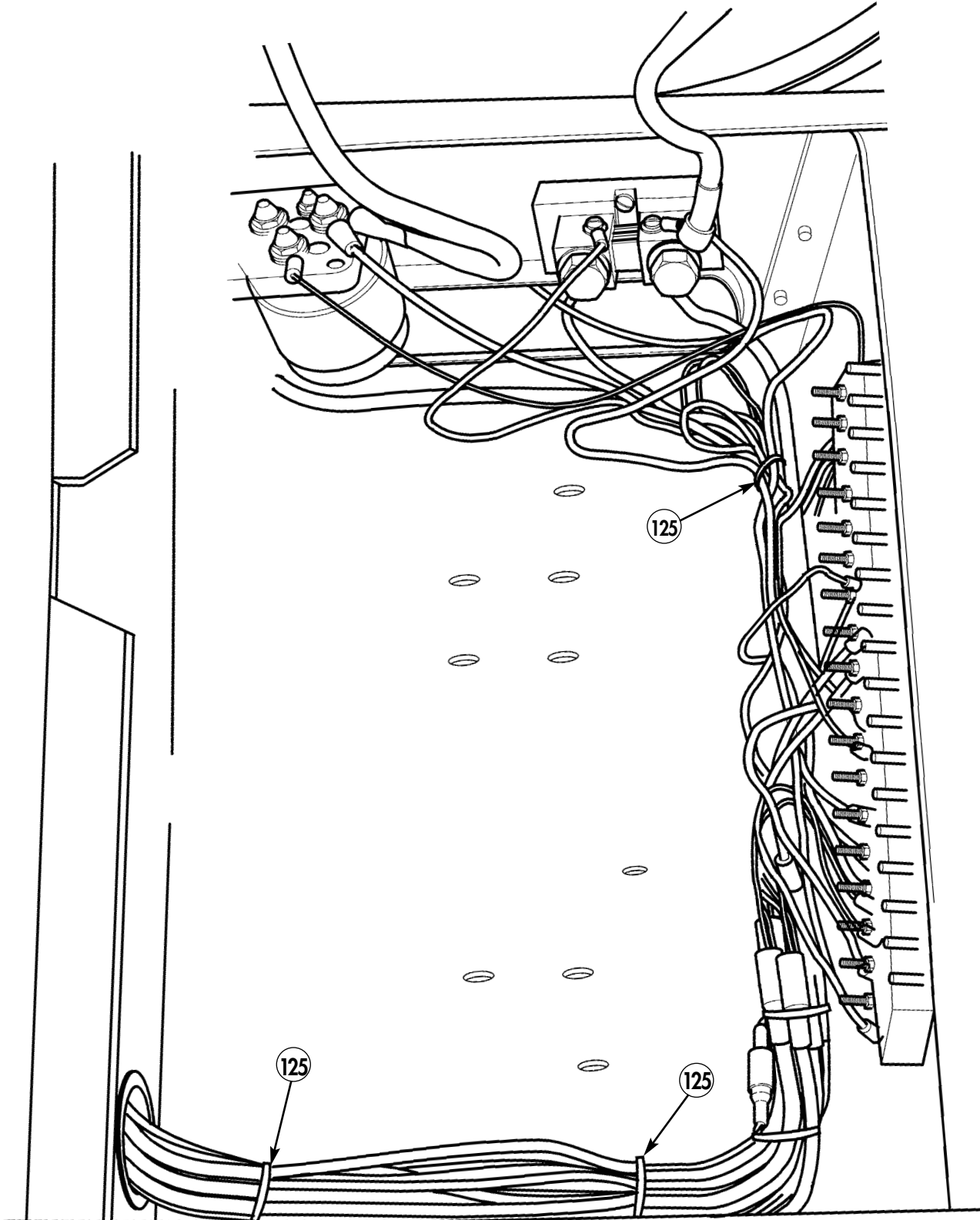

125. TIEDOWN STRAP – MS3367-1-0 – QTY. A/R

Figure 5-121.

31-67. Install batteries (130) in battery box (1).

31-68. Secure batteries with two nuts (131), screws (126), fender washers (132), steel angle (129), washers (128), and nuts (127).

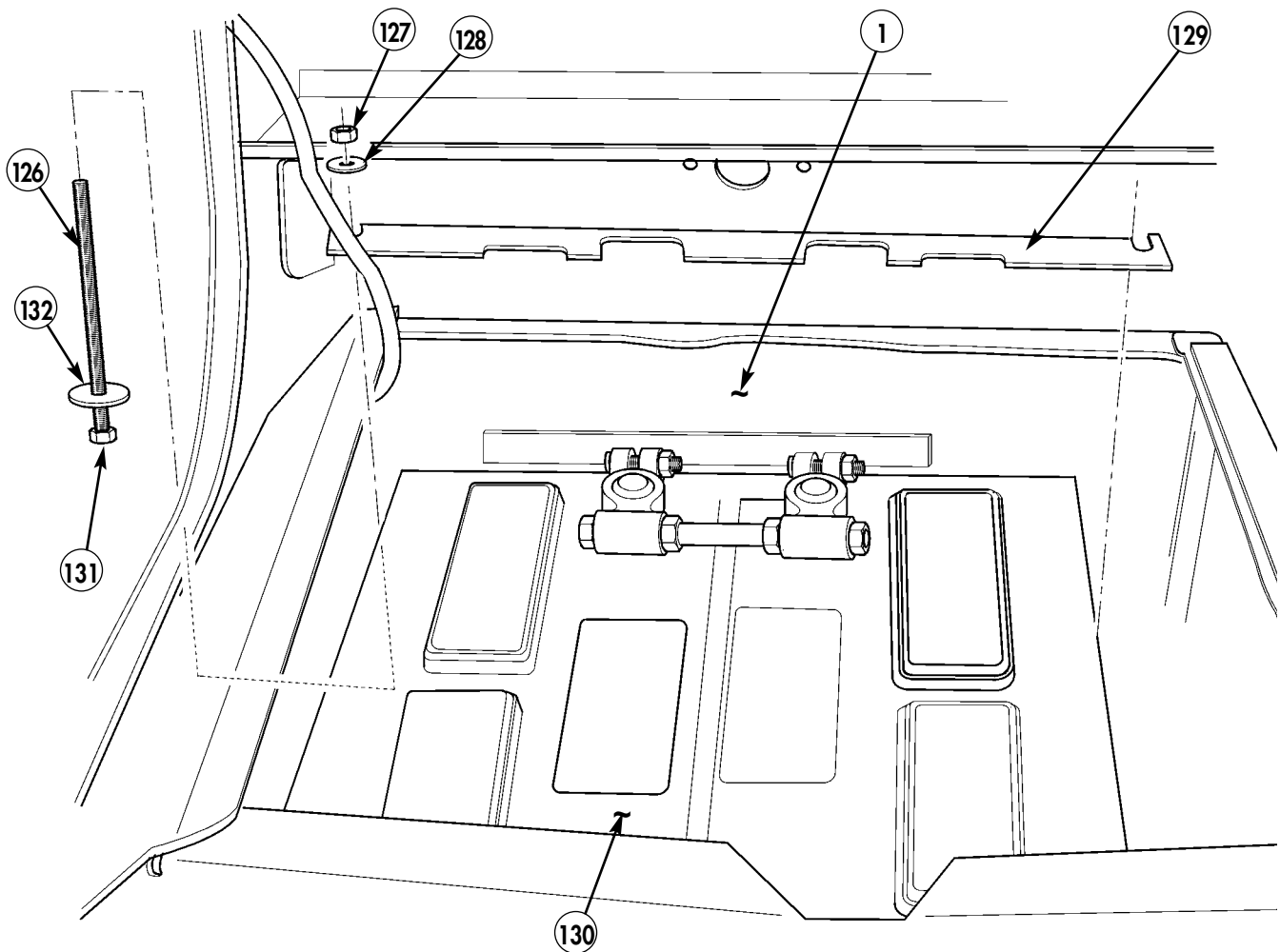

- 126. SCREW, ALL THREAD (5/16-18 X 10 1/4) – QTY. 2
- 127. NYLOK (5/16-18) – (PART OF PKMM 000-016) – QTY. 2
- 128. WASHER – MS27183-12 – (PART OF PKMM 000-016) – QTY. 2
- 129. STEEL ANGLE (PART OF PKMM 000-016) – QTY. 1
- 130. DEEP CYCLE BATTERY – PKMM 000-010 – QTY. 2
- 131. NUT – 0-952A59 (PART OF PKMM 000-016) – QTY. 2
- 132. WASHER, FENDER (5/16) – (PART OF PKMM 000-016) – QTY. 2

Figure 5-122.

31-69. Connect battery-to-shunt cable (32) and battery-to-solenoid cable (31) to batteries (130) with existing nut (133).

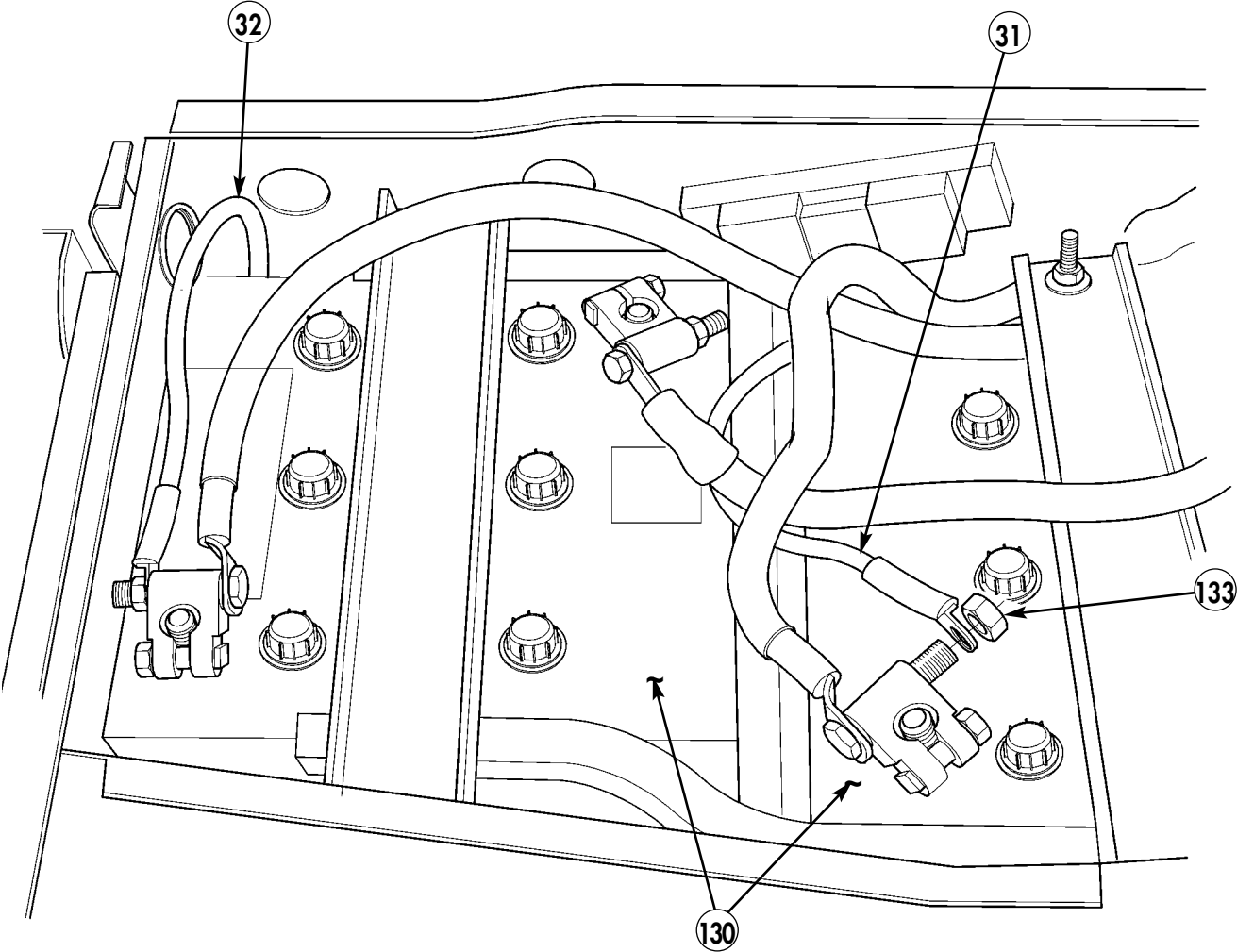
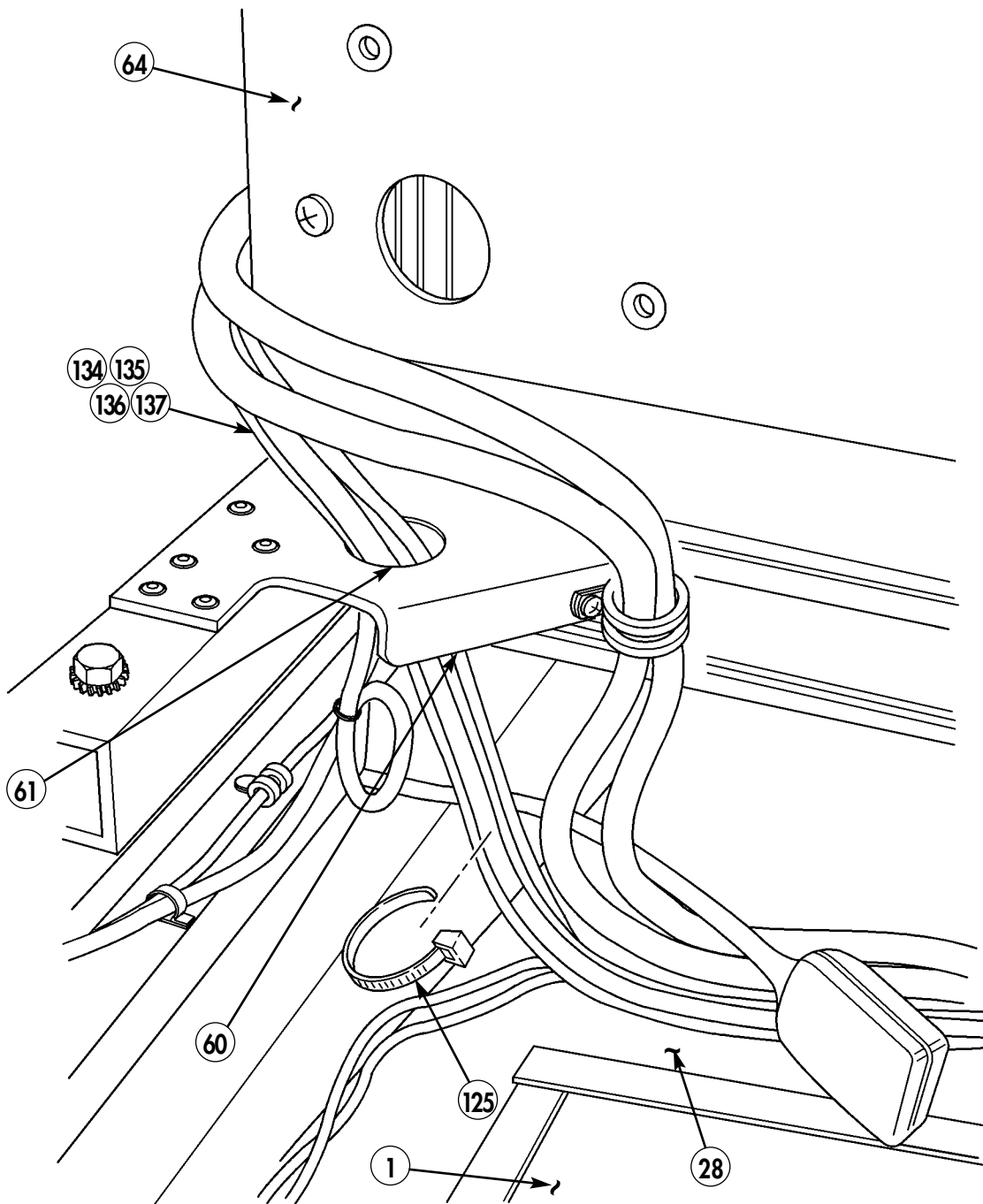

Figure 5-123.

31-70. Route four charger power cables (134), (135), (136), and (137) through hole (61) in frame (60) of multi-net rack (64), along tunnel (28), and into battery (1). Secure cables with tiedown strap (125).



125. TIEDOWN STRAP – MS3367-1-0 – QTY. A/R

Figure 5-124.

NOTE

Two charger cables connect to each battery. Connect positive and negative leads respectively.

- 31-71. Connect charger cable positive leads (138) to left and right rear batteries (145) and (144).
- 31-72. Connect charger cable negative leads (141) to left and right rear batteries (145) and (144).
- 31-73. Connect battery-to-battery cable (139) to left and right rear batteries (145) and (144).
- 31-74. Secure cables to batteries (145) and (144) with nuts (140).
- 31-75. Secure cables with tiedown straps (125).
- 31-76. Connect shunt cable (143) to left rear battery (145).
- 31-77. Connect solenoid cable (142) to right rear battery (144).

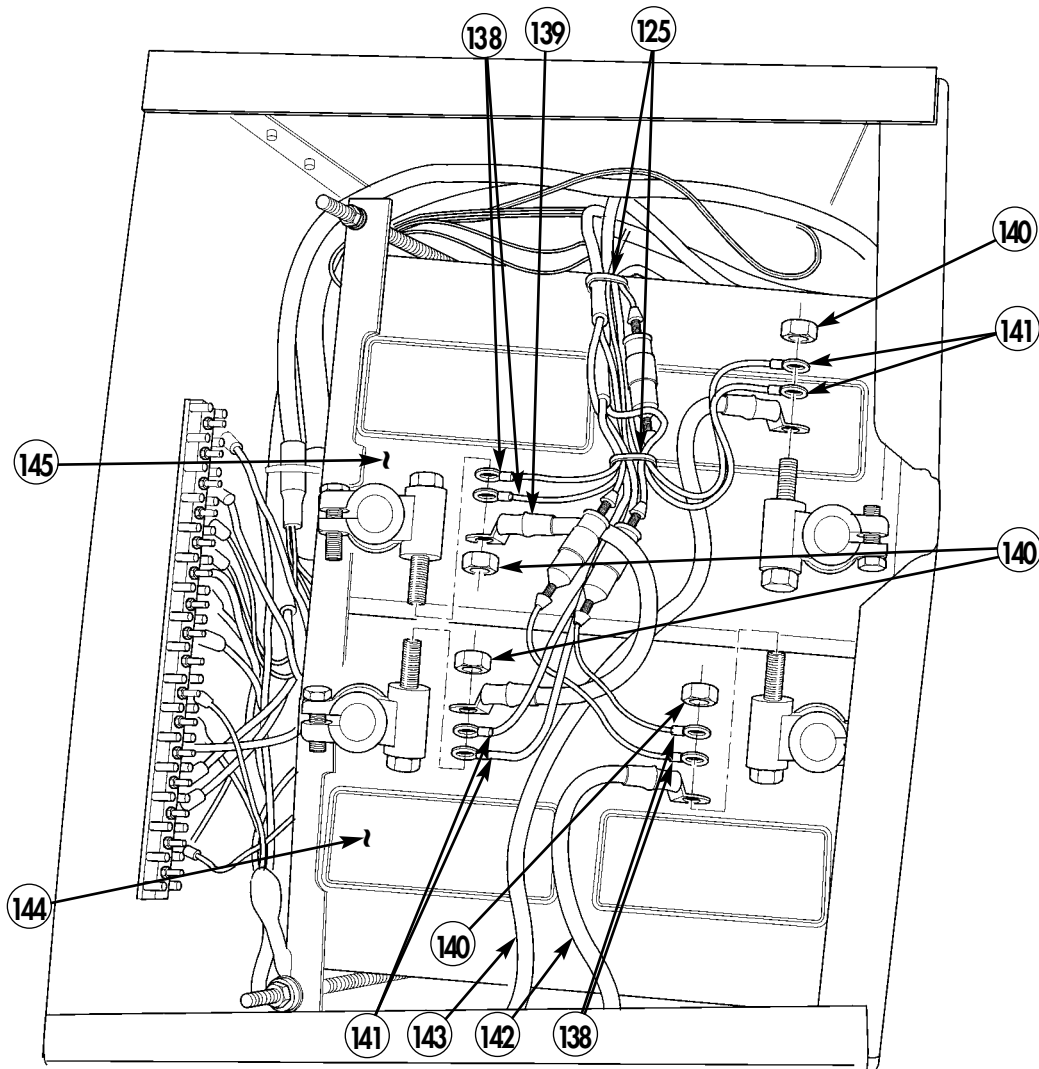

- 125. TIEDOWN STRAP – MS3367-1-0 – QTY. A/R
- 139. CABLE (BATTERY TO BATTERY) – RCSK 19639 – QTY. 1
- 142. CABLE (SOLENOID TO REAR BATTERY) – RCSK 19644 – QTY. 1
- 143. CABLE (SHUNT TO REAR BATTERY) – RCSK 19643 – QTY. 1

Figure 5-125.

31-78. Install terminal cover (146) on terminal block (7). Secure terminal cover (146) with nuts (147) and (148).

NOTE

Use aluminum flat bar as template to drill holes.

31-79. Drill four 0.156-in diameter holes (151) in lip of battery box (1).

31-80. Install rubber sheet (149) and aluminum flat bar (150) on battery box (1) with four rivets (152).

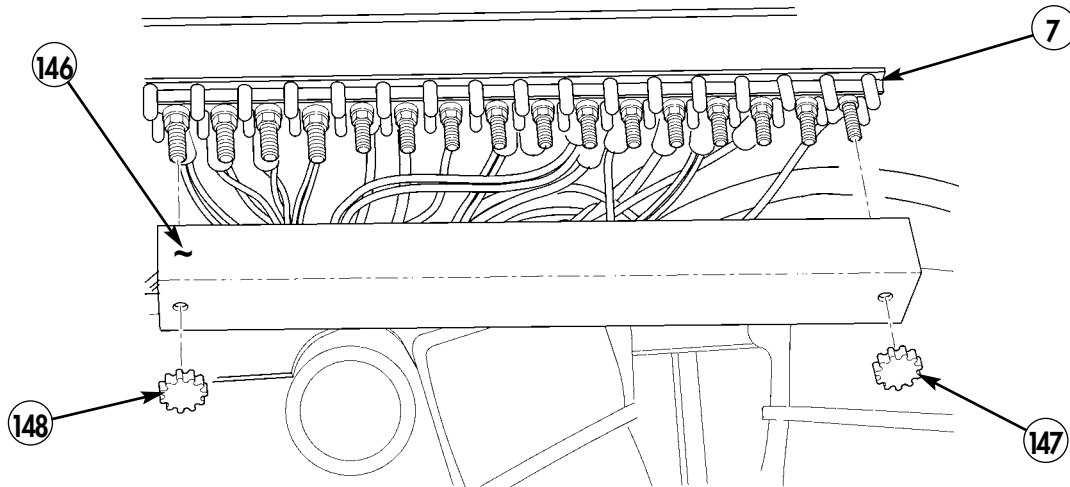

146. TERMINAL COVER – MS18029-IL-16 – QTY. 1

Figure 5-126.

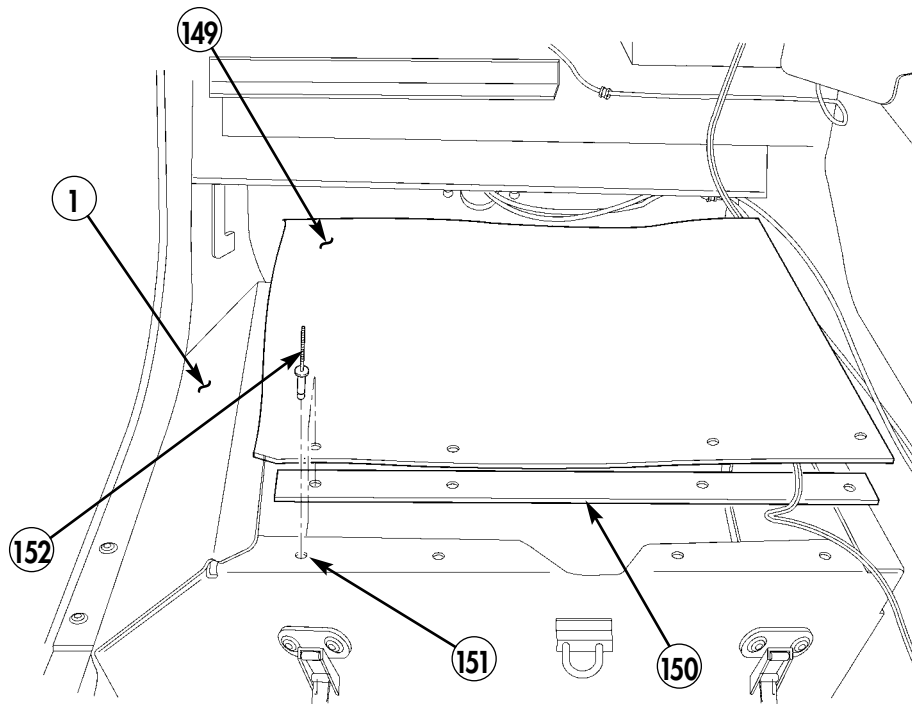

149. RUBBER SHEET – N/A – QTY. 1

150. ALUMINUM FLAT BAR – (PART OF PKMM 000-017) – QTY. 1

152. RIVET – M24243/1A403 – QTY. 4

Figure 5-127.

NOTE

Bundle any excess cable with tiedown straps and place behind multi-net rack.

31-81. Install convoluted tubing (153) over cabling with tiedown straps (125).

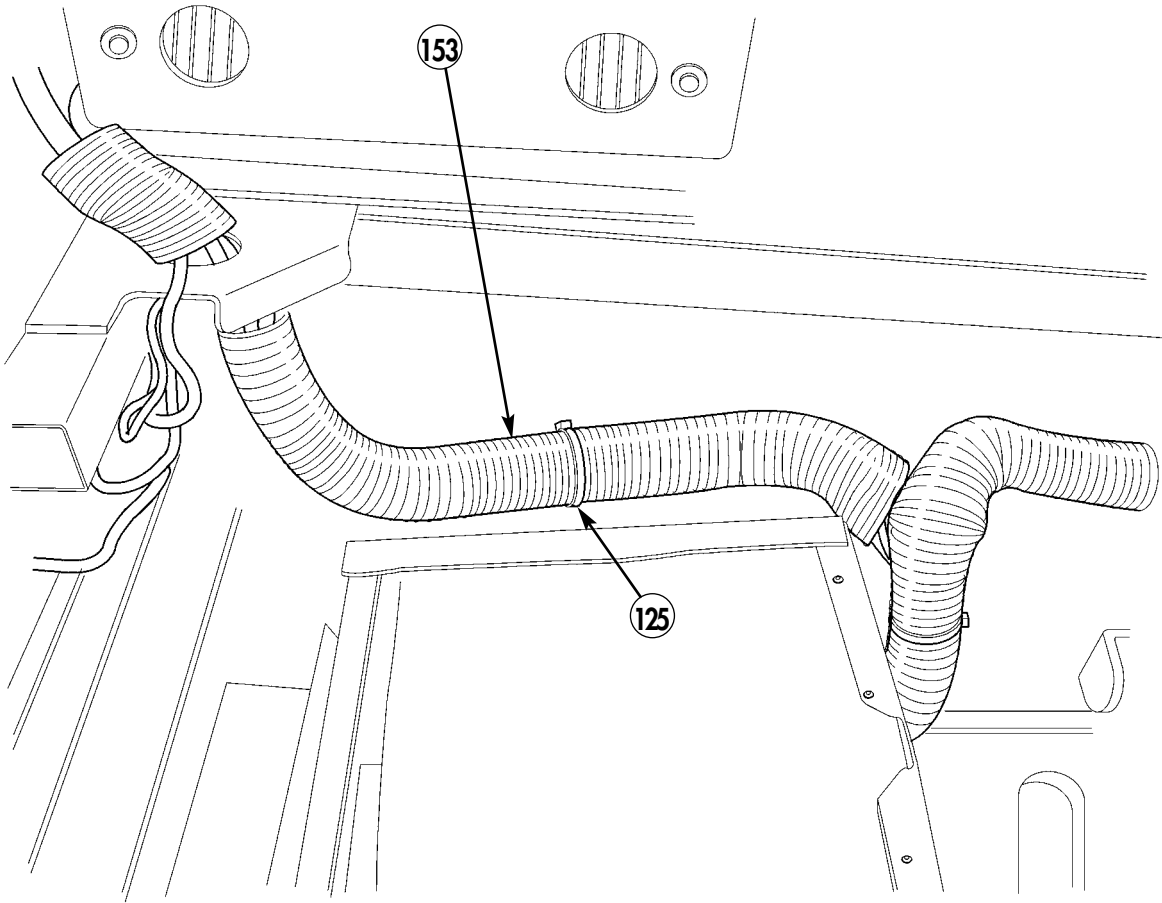

153. CONVOLUTED TUBING – N/A – QTY. A/R

Figure 5-128.

SECTION XXXII. WINDSHIELD ARMOR MODIFICATION

NOTE

Perform following steps for vehicles with bolt-on armor installed.

- 32-1. Remove four capscrews (5) and left capping ring (4) from left side of windshield frame (1).
- 32-2. Remove four capscrews (5) and right capping ring (6) from right side of windshield frame (1).
- 32-3. Remove five capscrews (3) and upper capping ring (2) from windshield frame (1).

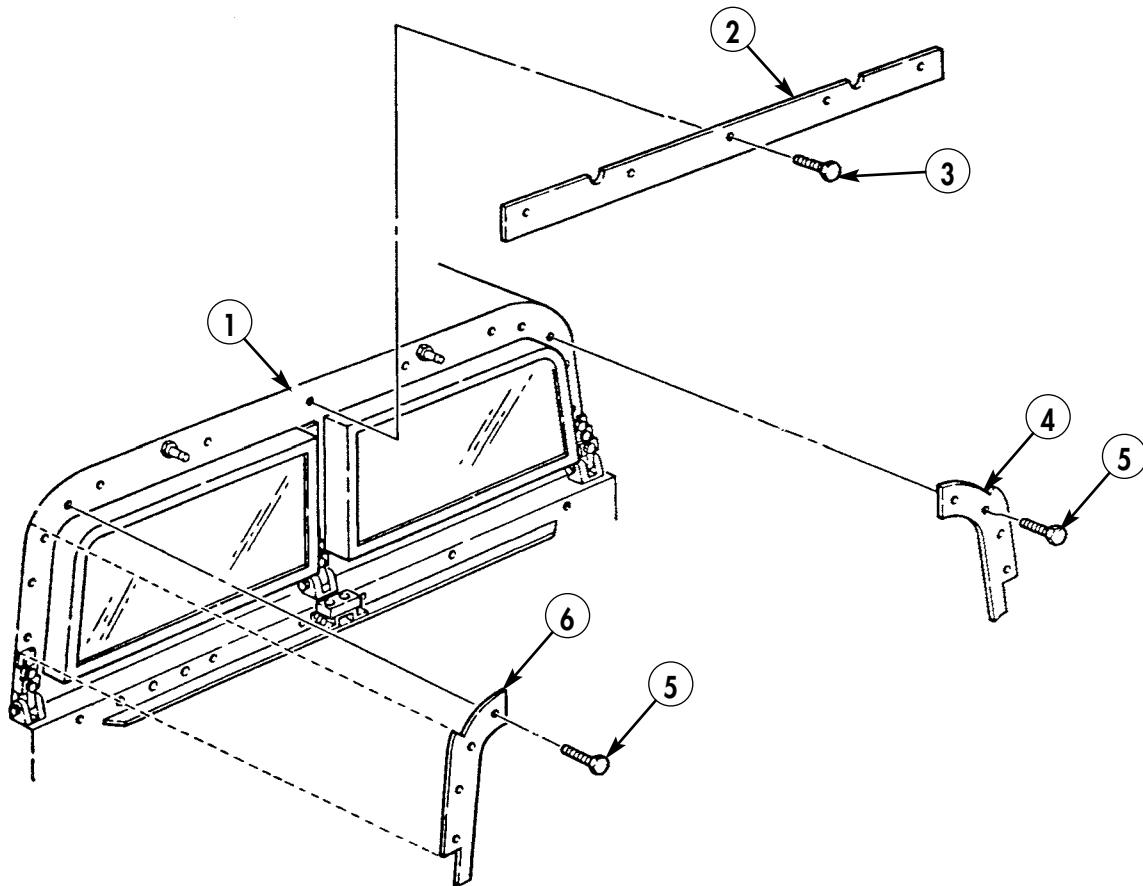

Figure 5-129.

NOTE

Left side shown; right side opposite.

32-4. Locate, mark, and remove section of armor on left capping ring (4). Repeat for right side.

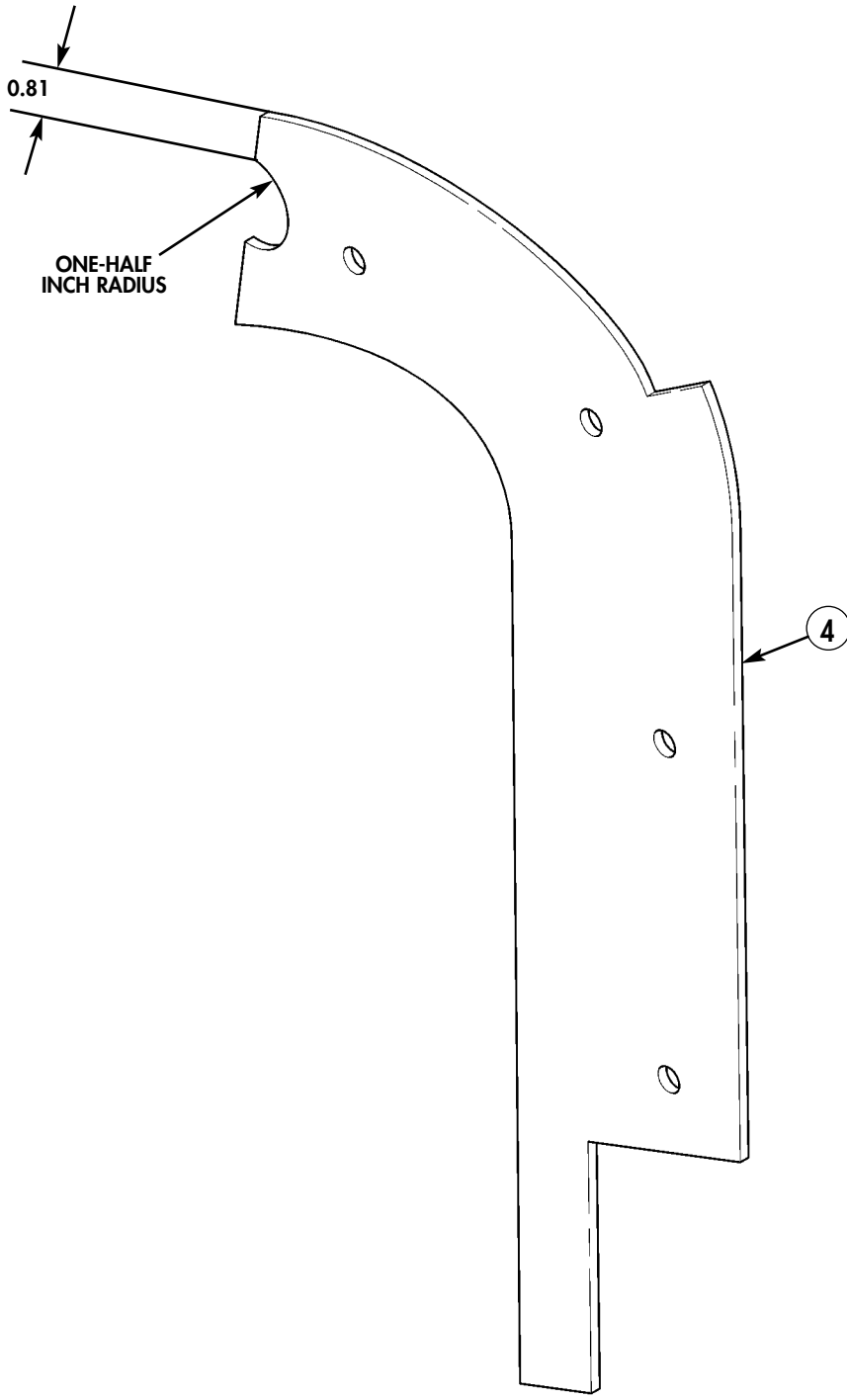

Figure 5-130.

NOTE

Right side shown; left side opposite.

32-5. Locate, mark, and remove sections of armor on upper capping ring (2).

32-6. Spot paint all exposed metal surfaces. (Refer to TM 43-0139.)

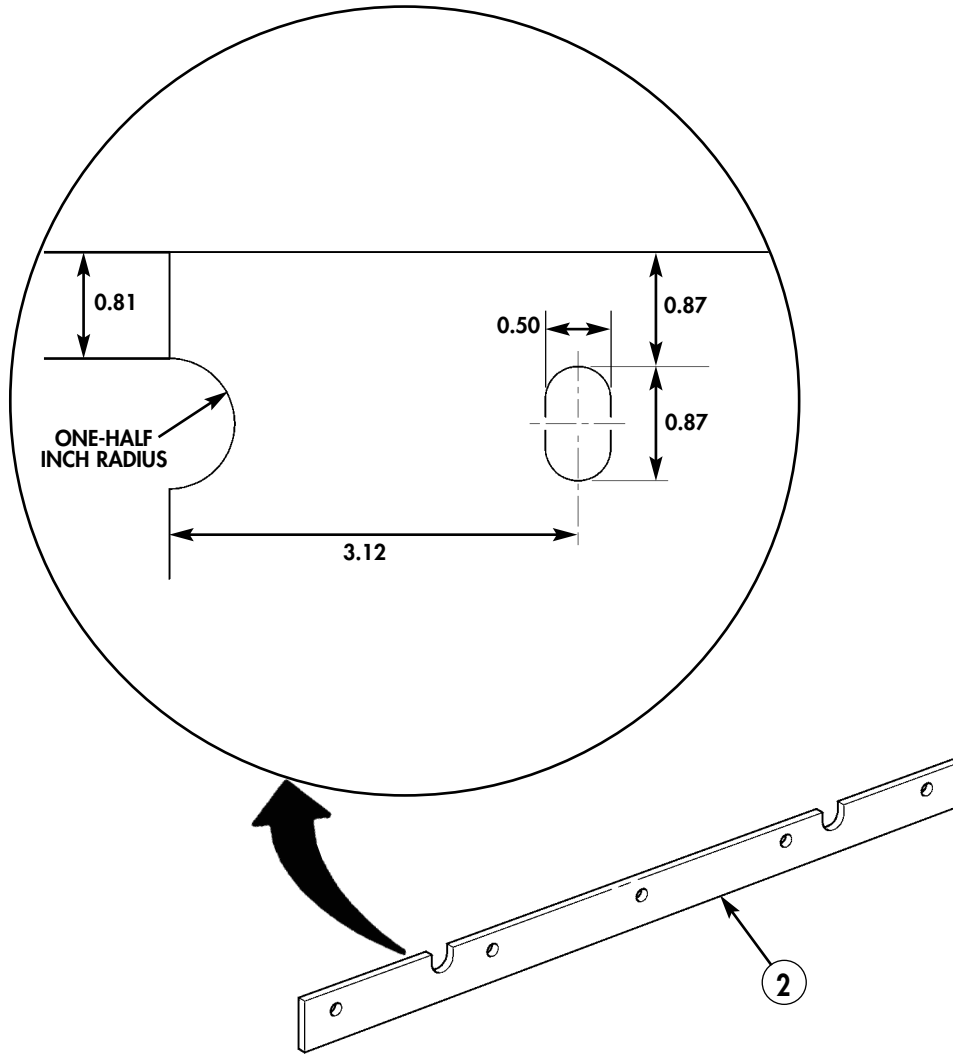
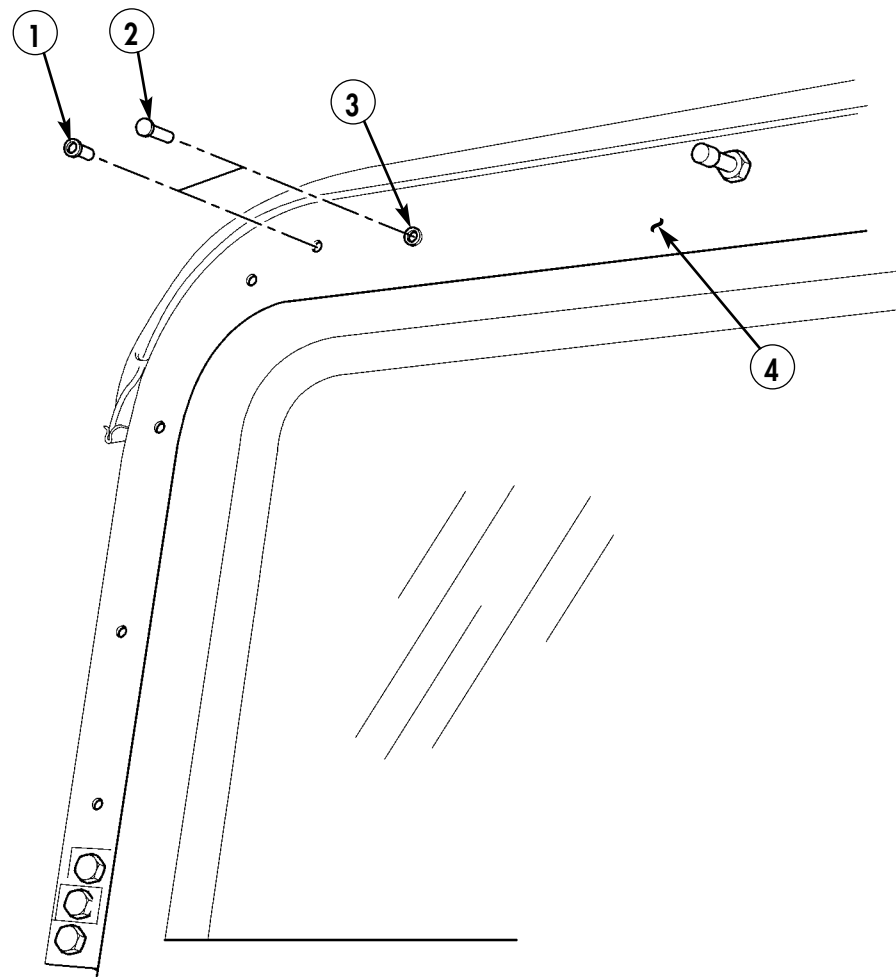

Figure 5-131.

Section XXXIII. ARMOR AND ANTENNA INSTALLATION (WITH BOLT-ON ARMOR)

- 33-1.** Remove two plugs (2) from right side of windshield frame (4).
33-2. Install wellnuts (1) and (3) in right side of windshield frame.



1. WELLNUT - 12339397-6 - QTY. 1
3. WELLNUT - 12339397-3 - QTY. 1

Figure 5-132.

NOTE

It may be necessary to drill pilot hole prior to drilling 0.562-in. diameter hole.

- 33-3.** Locate, mark, and drill one 0.562-in. diameter hole (5) on right side of A-pillar (6).

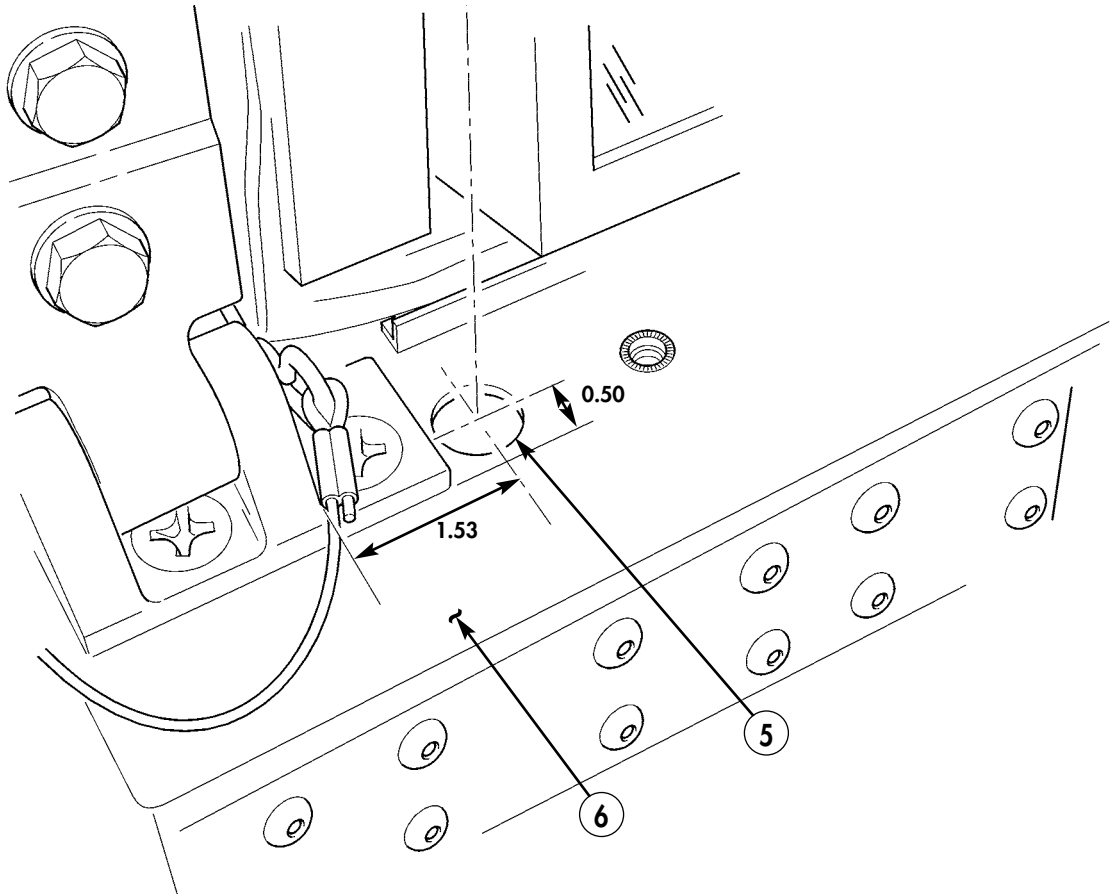

Figure 5-133.

- 33-4. Install modified upper capping ring (7) on windshield frame (4) with five existing capscrews (8).
- 33-5. Install modified right capping ring (11) on right side of windshield frame (4) with four existing capscrews (10).
- 33-6. Install modified left capping ring (9) on left side of windshield frame (4) with four existing capscrews (10).

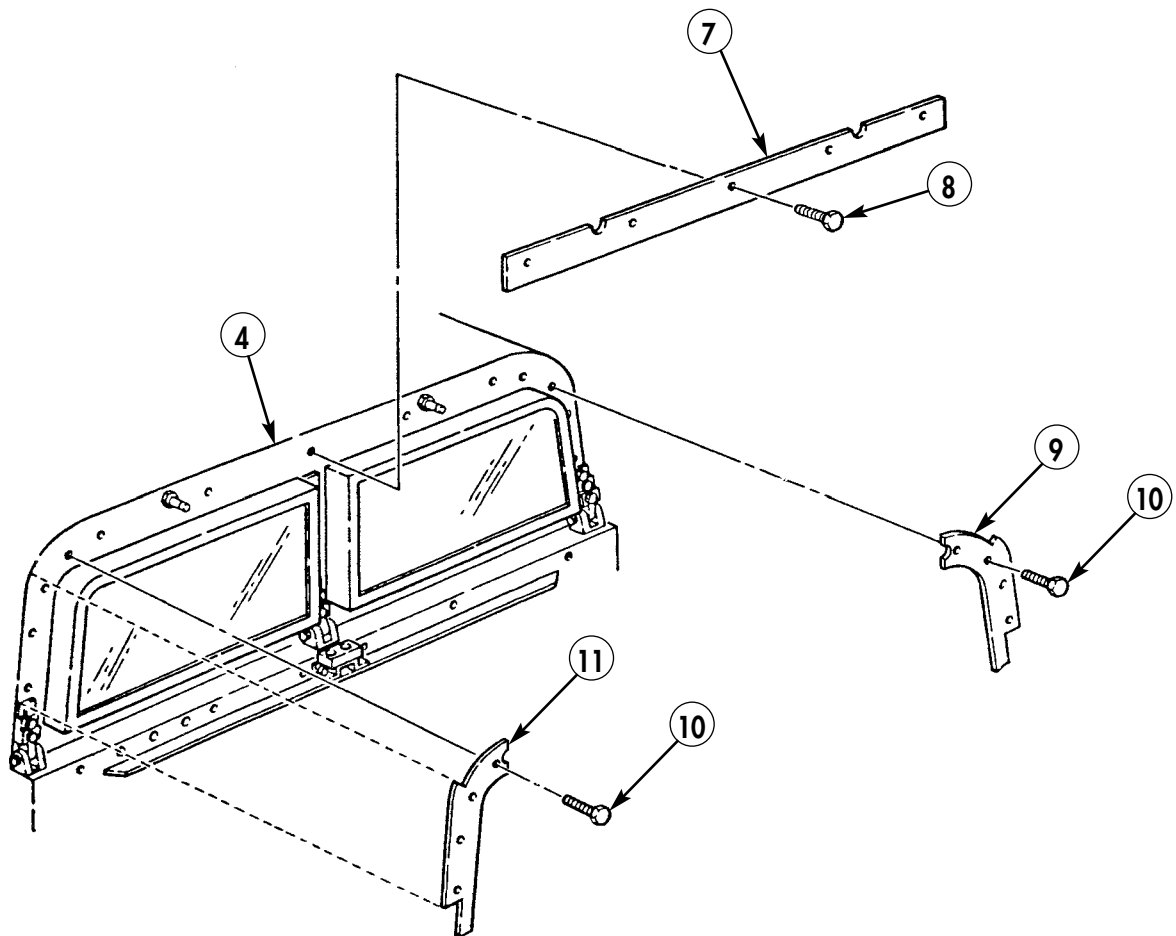
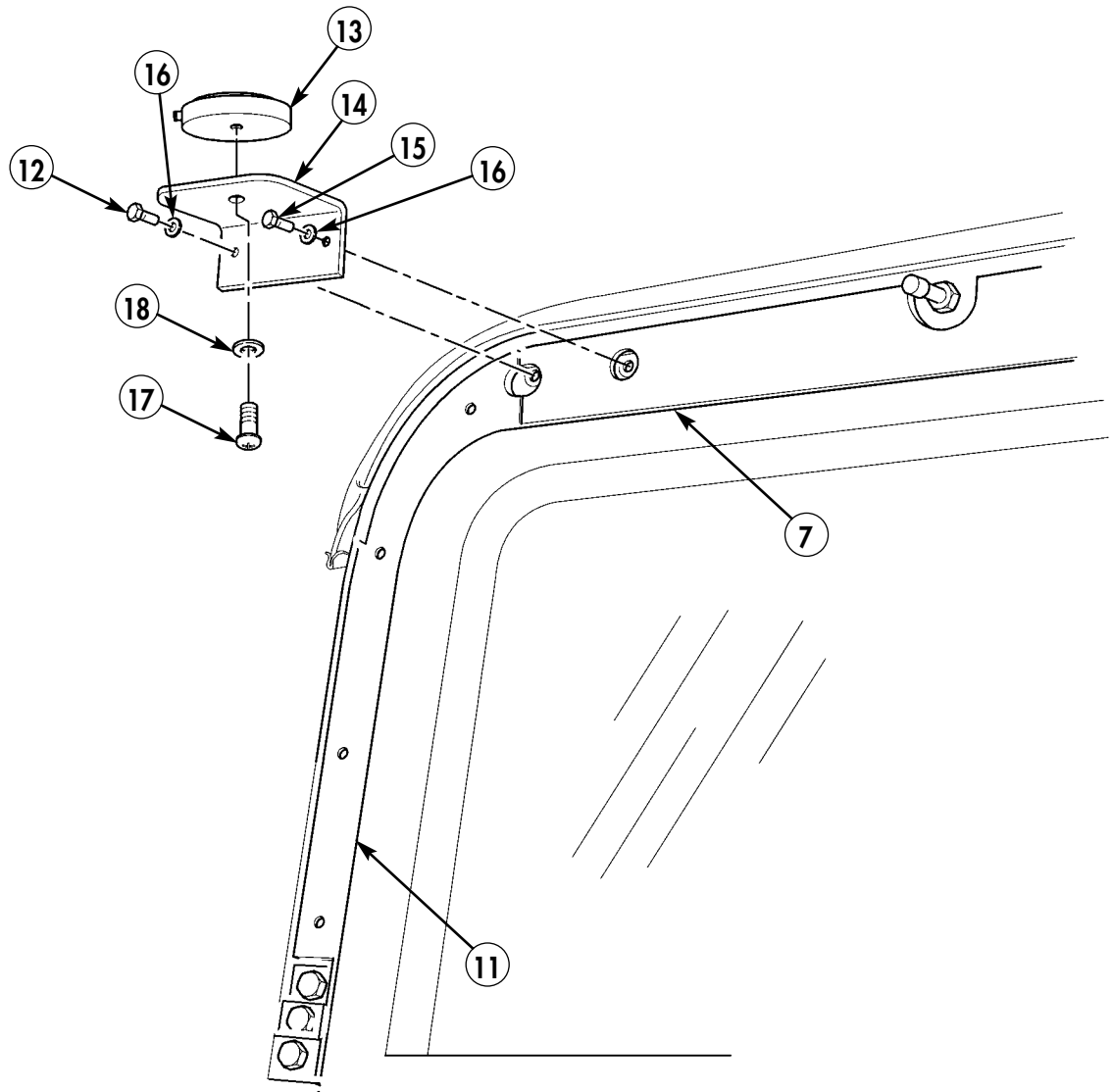

Figure 5-134.

33-7. Install antenna (13) on support (14) with lockwasher (18) and capscrew (17).

33-8. Install support (14) on right capping ring (11) and upper capping ring (7) with capscrews (12) and (15) and two washers (16).



- 12. CAPSCREW - B1821BH025C125N - QTY. 1
- 13. PLGR ANTENNA - AT575-030 - QTY. 1
- 14. PLGR ANTENNA MOUNT BRACKET - 12480578 - QTY. 1
- 15. CAPSCREW - B1821BH025C175N - QTY. 1
- 16. WASHER - 2436161 - QTY. 2
- 17. CAPSCREW - MS35207-261 - QTY. 1
- 18. LOCKWASHER - MS35338-43 - QTY. 1

Figure 5-135.

Section XXXIV. ANTENNA CABLE INSTALLATION (WITH BOLT-ON ARMOR)

- 34-1.** Route antenna cable (1) through hole (5) and connect antenna cable (1) to antenna (2).
- 34-2.** Remove self-tapping screw (4) from right capping ring (3).
- 34-3.** Secure antenna cable (1) to right capping ring (3) with clamp (6) and existing self-tapping screw (4).

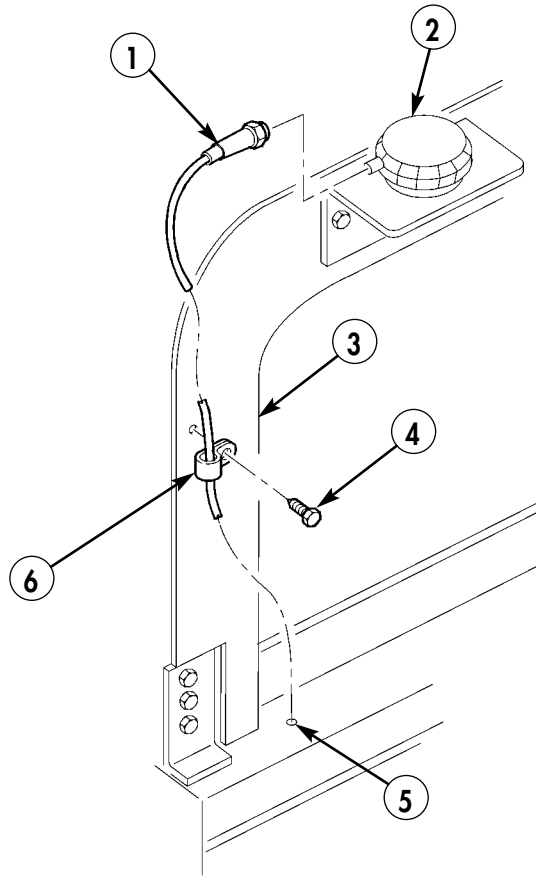

- 1. ANTENNA CABLE – A32551281W23 – QTY. 1**
6. CLAMP – MS21333-96 – QTY. 1

Figure 5-136.

- 34-4. Split grommet (8) and install on antenna cable (1).
- 34-5. Wrap electrical tape (7) around antenna cable (1).
- 34-6. Install antenna cable (1) with electrical tape (7) in grommet (8).

NOTE

Apply sealing compound on grommet.

- 34-7. Install grommet (8) in hole (5) on A-pillar (9).

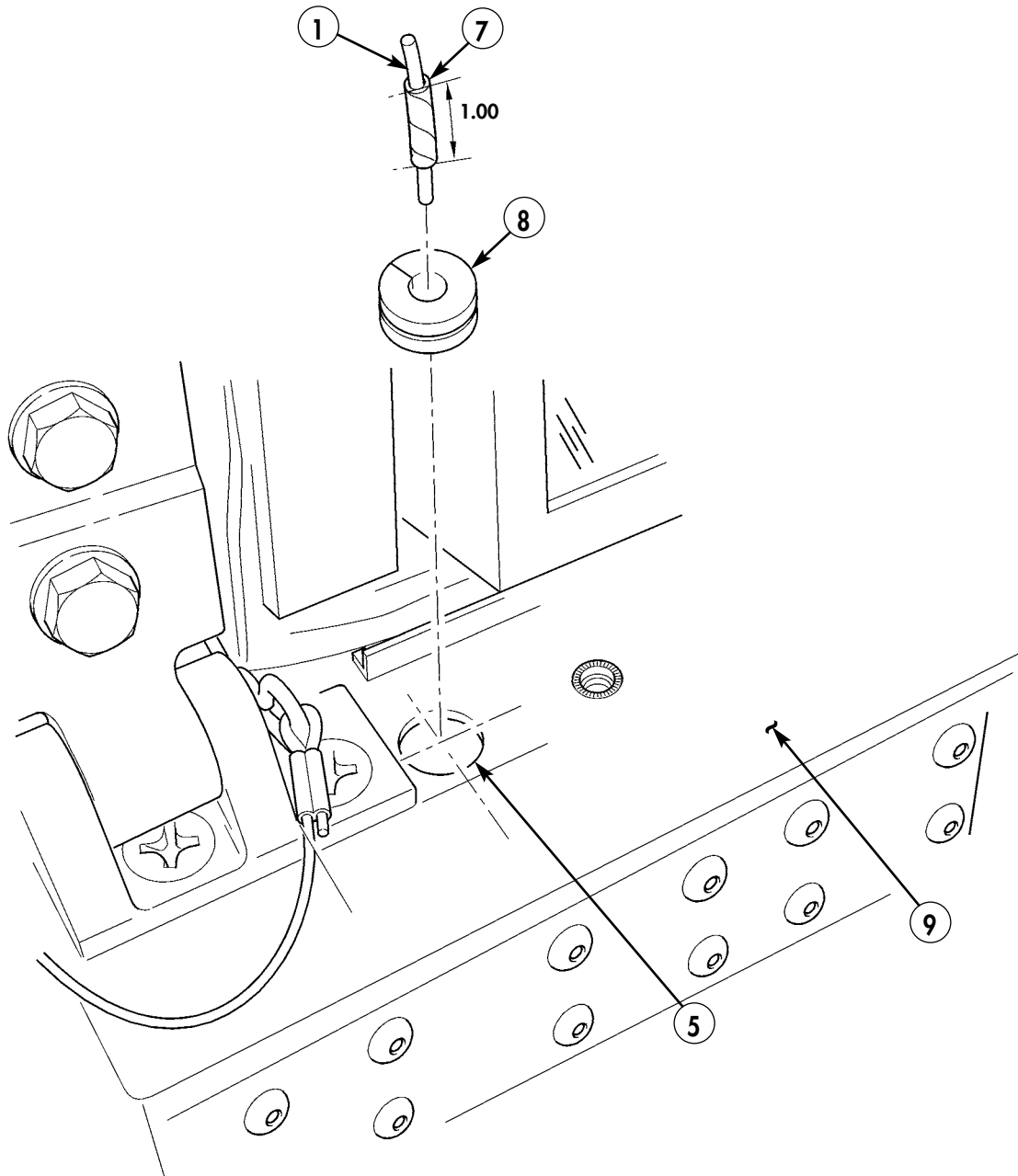

- 7. ELECTRICAL TAPE – HH-I-595 – QTY. A/R
- 8. GROMMET – MS35489-31 – QTY. 1

Figure 5-137.

- 34-8. Route antenna cable (1) behind heater shield (12) to installation mount (13).
- 34-9. Locate, mark, and drill one 0.147-in. diameter hole (16) in plenum (9).
- 34-10. Secure antenna cable (1) to plenum (9) with clamp (11) and self-tapping screw (10).
- 34-11. Secure excess antenna cable (1) behind installation mount (13) on integrated radio rack (15) with tiedown strap (14).

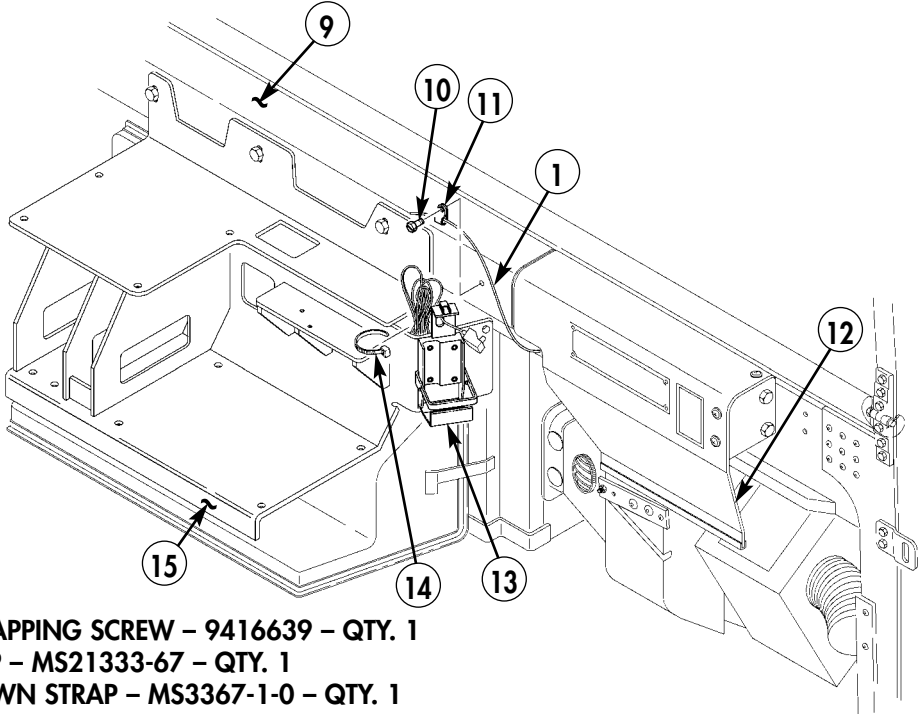

- 10. SELF-TAPPING SCREW - 9416639 - QTY. 1
- 11. CLAMP - MS21333-67 - QTY. 1
- 14. TIEDOWN STRAP - MS3367-1-0 - QTY. 1

Figure 5-138.

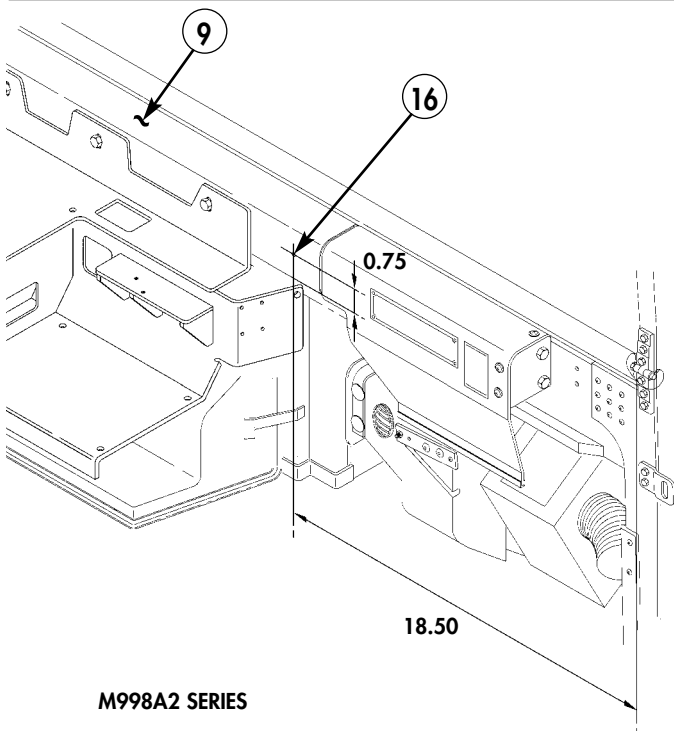

Figure 5-139.

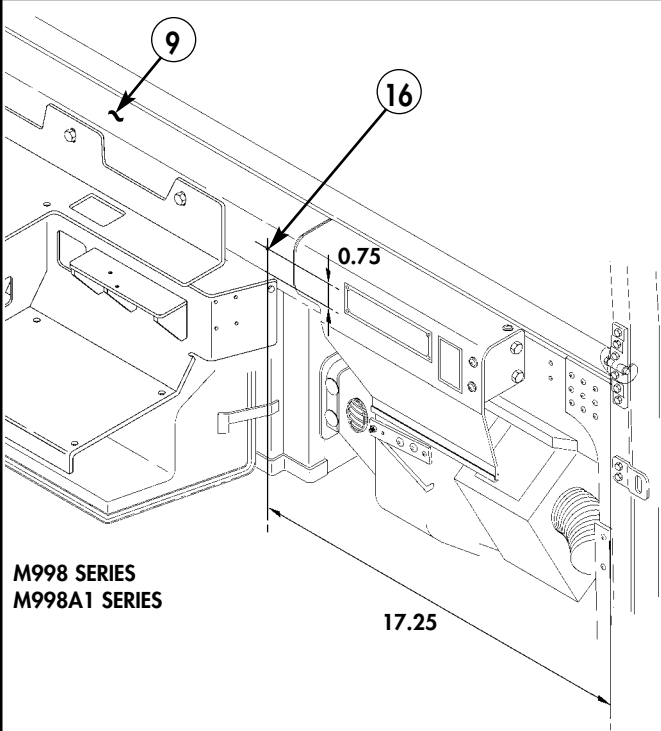

Figure 5-140.

By Order of the Secretary of the Army:

PETER J. SCHOOMAKER
General, United States Army
Chief of Staff

Official:



SANDRA R. RILEY
Administrative Assistant to the
Secretary of the Army
0520910

Distribution:

To be distributed in accordance with the Initial Distribution Number (IDN) 344825 requirements for TB 9-2320-280-35-10.

RECOMMENDED CHANGES TO PUBLICATIONS AND BLANK FORMS For use of this form, see AR 25-30; the proponent agency is ODISC4.	Use Part II (reverse) for Repair Parts and Special Tools Lists (RPSTL) and Supply Catalogs/Supply Manuals (SC/SM).	DATE: <p style="text-align: center;">5 Dec. 2005</p>
---	--	--

TO: (Forward to proponent of publication or form) (include ZIP code) AMSTA-LC-LPIT/Tech Pubs, TACOM-RI 1 Rock Island Arsenal Rock Island, IL 61299-7630	FROM: (Activity and location) (include ZIP code) <p style="text-align: center;">Co. B, 1st BN, 2nd Brigade Ft. Hood, TX 76445</p>
---	---

PART I - ALL PUBLICATIONS (EXCEPT RPSTL AND SC/SM) AND BLANK FORMS

PUBLICATION/FORM NUMBER <p style="text-align: center;">TB 9-2320-280-35-10</p>	DATE <p style="text-align: center;">17 SEP. 2005</p>	TITLE <p style="text-align: center;">TECHNICAL BULLETIN INSTALLATION INSTRUCTIONS</p>
--	--	---

ITEM NO.	PAGE NO.	PARA-GRAPH	LINE NO.*	FIGURE NO.	TABLE NO.	RECOMMENDED CHANGES AND REASON (Provide exact wording of recommended changes, if possible)
1	5-39		21-5	5-51		<p style="text-align: center;">Grommet MS21266-4N should be 4.250 inches long.</p>

SAMPLE

**Reference to line numbers within the paragraph or subparagraph.*

TYPED NAME, GRADE, OR TITLE <p style="text-align: center;">Pat Smith</p>	TELEPHONE EXCHANGE/AUTOVON, PLUS EXTENSION <p style="text-align: center;">AV272-4162</p>	SIGNATURE <p style="text-align: center;"><i>Pat Smith</i></p>
--	--	--

TO: <i>(Forward direct to addressee listed in publication)</i> AMSTA-LC-LPIT/Tech Pubs, TACOM-RI 1 Rock Island Arsenal Rock Island, IL 61299-7630	FROM: <i>(Activity and location) (include ZIP code)</i>	DATE:
--	---	-------

PART II - REPAIR PARTS AND SPECIAL TOOLS LISTS AND SUPPLY CATALOGS/SUPPLY MANUALS

PUBLICATION/FORM NUMBER TB 9-2320-280-35-10	DATE 17 SEP. 2005	TITLE TECHNICAL BULLETIN INSTALLATION INSTRUCTIONS
--	----------------------	--

PAGE NO.	COLM NO.	LINE NO.	NATIONAL STOCK NUMBER	REFERENCE NO.	FIGURE NO.	ITEM NO.	TOTAL NO. OF MAJOR ITEMS SUPPORTED	RECOMMENDED ACTION
<h1>SAMPLE</h1>								

PART III - REMARKS *(Any general remarks or recommendations, or suggestions for improvement of publications and blank forms. Additional blank sheets may be used if more space is needed.)*

TYPED NAME, GRADE, OR TITLE	TELEPHONE EXCHANGE/AUTOVON, PLUS EXTENSION	SIGNATURE
-----------------------------	--	-----------

RECOMMENDED CHANGES TO PUBLICATIONS AND BLANK FORMS For use of this form, see AR 25-30; the proponent agency is ODISC4.				Use Part II (reverse) for Repair Parts and Special Tools Lists (RPSTL) and Supply Catalogs/Supply Manuals (SC/SM).			DATE:	
TO: <i>(Forward to proponent of publication or form) (include ZIP code)</i> AMSTA-LC-LPIT/Tech Pubs, TACOM-RI 1 Rock Island Arsenal Rock Island, IL 61299-7630				FROM: <i>(Activity and location) (include ZIP code)</i>				
PART I – ALL PUBLICATIONS (EXCEPT RPSTL AND SC/SM) AND BLANK FORMS								
PUBLICATION/Form NUMBER TB 9-2320-280-35-10				DATE 17 SEP. 2005		TITLE TECHNICAL BULLETIN INSTALLATION INSTRUCTIONS		
ITEM NO.	PAGE NO.	PARA-GRAPH	LINE NO.*	FIGURE NO.	TABLE NO.	RECOMMENDED CHANGES AND REASON <i>(Provide exact wording of recommended changes, if possible)</i>		
<i>*Reference to line numbers within the paragraph or subparagraph.</i>								
TYPED NAME, GRADE, OR TITLE				TELEPHONE EXCHANGE/AUTOVON, PLUS EXTENSION		SIGNATURE		

TO: <i>(Forward direct to addressee listed in publication)</i> AMSTA-LC-LPIT/Tech Pubs, TACOM-RI 1 Rock Island Arsenal Rock Island, IL 61299-7630	FROM: <i>(Activity and location) (include ZIP code)</i>	DATE:
---	--	--------------

PART II - REPAIR PARTS AND SPECIAL TOOLS LISTS AND SUPPLY CATALOGS/SUPPLY MANUALS

PUBLICATION/FORM NUMBER TB 9-2320-280-35-10	DATE 17 SEP. 2005	TITLE TECHNICAL BULLETIN INSTALLATION INSTRUCTIONS
---	-----------------------------	---

PAGE NO.	COLM NO.	LINE NO.	NATIONAL STOCK NUMBER	REFERENCE NO.	FIGURE NO.	ITEM NO.	TOTAL NO. OF MAJOR ITEMS SUPPORTED	RECOMMENDED ACTION

PART III - REMARKS *(Any general remarks or recommendations, or suggestions for improvement of publications and blank forms. Additional blank sheets may be used if more space is needed.)*

--

TYPED NAME, GRADE, OR TITLE	TELEPHONE EXCHANGE/AUTOVON, PLUS EXTENSION	SIGNATURE

RECOMMENDED CHANGES TO PUBLICATIONS AND BLANK FORMS For use of this form, see AR 25-30; the proponent agency is ODISC4.				Use Part II (reverse) for Repair Parts and Special Tools Lists (RPSTL) and Supply Catalogs/Supply Manuals (SC/SM).		DATE:
TO: <i>(Forward to proponent of publication or form) (include ZIP code)</i> AMSTA-LC-LPIT/Tech Pubs, TACOM-RI 1 Rock Island Arsenal Rock Island, IL 61299-7630				FROM: <i>(Activity and location) (include ZIP code)</i>		
PART I - ALL PUBLICATIONS (EXCEPT RPSTL AND SC/SM) AND BLANK FORMS						
PUBLICATION/FORM NUMBER TB 9-2320-280-35-10			DATE 17 SEP. 2005		TITLE TECHNICAL BULLETIN INSTALLATION INSTRUCTIONS	
ITEM NO.	PAGE NO.	PARA-GRAPH	LINE NO.*	FIGURE NO.	TABLE NO.	RECOMMENDED CHANGES AND REASON <i>(Provide exact wording of recommended changes, if possible)</i>
<i>*Reference to line numbers within the paragraph or subparagraph.</i>						
TYPED NAME, GRADE, OR TITLE				TELEPHONE EXCHANGE/AUTOVON, PLUS EXTENSION		SIGNATURE

TO: <i>(Forward direct to addressee listed in publication)</i> AMSTA-LC-LPIT/Tech Pubs, TACOM-RI 1 Rock Island Arsenal Rock Island, IL 61299-7630	FROM: <i>(Activity and location) (include ZIP code)</i>	DATE:
--	---	-------

PART II - REPAIR PARTS AND SPECIAL TOOLS LISTS AND SUPPLY CATALOGS/SUPPLY MANUALS

PUBLICATION/FORM NUMBER TB 9-2320-280-35-10	DATE 17 SEP. 2005	TITLE TECHNICAL BULLETIN INSTALLATION INSTRUCTIONS
--	----------------------	--

PAGE NO.	COLM NO.	LINE NO.	NATIONAL STOCK NUMBER	REFERENCE NO.	FIGURE NO.	ITEM NO.	TOTAL NO. OF MAJOR ITEMS SUPPORTED	RECOMMENDED ACTION

PART III - REMARKS *(Any general remarks or recommendations, or suggestions for improvement of publications and blank forms. Additional blank sheets may be used if more space is needed.)*

TYPED NAME, GRADE, OR TITLE	TELEPHONE EXCHANGE/AUTOVON, PLUS EXTENSION	SIGNATURE
-----------------------------	--	-----------

RECOMMENDED CHANGES TO PUBLICATIONS AND BLANK FORMS For use of this form, see AR 25-30; the proponent agency is ODISC4.				Use Part II (reverse) for Repair Parts and Special Tools Lists (RPSTL) and Supply Catalogs/Supply Manuals (SC/SM).		DATE:
TO: (Forward to proponent of publication or form) (include ZIP code) AMSTA-LC-LPIT/Tech Pubs, TACOM-RI 1 Rock Island Arsenal Rock Island, IL 61299-7630				FROM: (Activity and location) (include ZIP code)		
PART I - ALL PUBLICATIONS (EXCEPT RPSTL AND SC/SM) AND BLANK FORMS						
PUBLICATION/FORM NUMBER TB 9-2320-280-35-10			DATE 17 SEP. 2005		TITLE TECHNICAL BULLETIN INSTALLATION INSTRUCTIONS	
ITEM NO.	PAGE NO.	PARA-GRAPH	LINE NO.*	FIGURE NO.	TABLE NO.	RECOMMENDED CHANGES AND REASON <i>(Provide exact wording of recommended changes, if possible)</i>
<i>*Reference to line numbers within the paragraph or subparagraph.</i>						
TYPED NAME, GRADE, OR TITLE				TELEPHONE EXCHANGE/AUTOVON, PLUS EXTENSION		SIGNATURE

TO: <i>(Forward direct to addressee listed in publication)</i> AMSTA-LC-LPIT/Tech Pubs, TACOM-RI 1 Rock Island Arsenal Rock Island, IL 61299-7630	FROM: <i>(Activity and location) (include ZIP code)</i>	DATE:
---	--	--------------

PART II - REPAIR PARTS AND SPECIAL TOOLS LISTS AND SUPPLY CATALOGS/SUPPLY MANUALS

PUBLICATION/FORM NUMBER TB 9-2320-280-35-10	DATE 17 SEP. 2005	TITLE TECHNICAL BULLETIN INSTALLATION INSTRUCTIONS
---	-----------------------------	---

PAGE NO.	COLM NO.	LINE NO.	NATIONAL STOCK NUMBER	REFERENCE NO.	FIGURE NO.	ITEM NO.	TOTAL NO. OF MAJOR ITEMS SUPPORTED	RECOMMENDED ACTION

PART III - REMARKS *(Any general remarks or recommendations, or suggestions for improvement of publications and blank forms. Additional blank sheets may be used if more space is needed.)*

--

TYPED NAME, GRADE, OR TITLE	TELEPHONE EXCHANGE/AUTOVON, PLUS EXTENSION	SIGNATURE

